

INSTALLATION INSTRUCTION SHEET

MPG-1C Metering Pulse Generator

V2.53 Firmware for use with SSI 5951 dongle

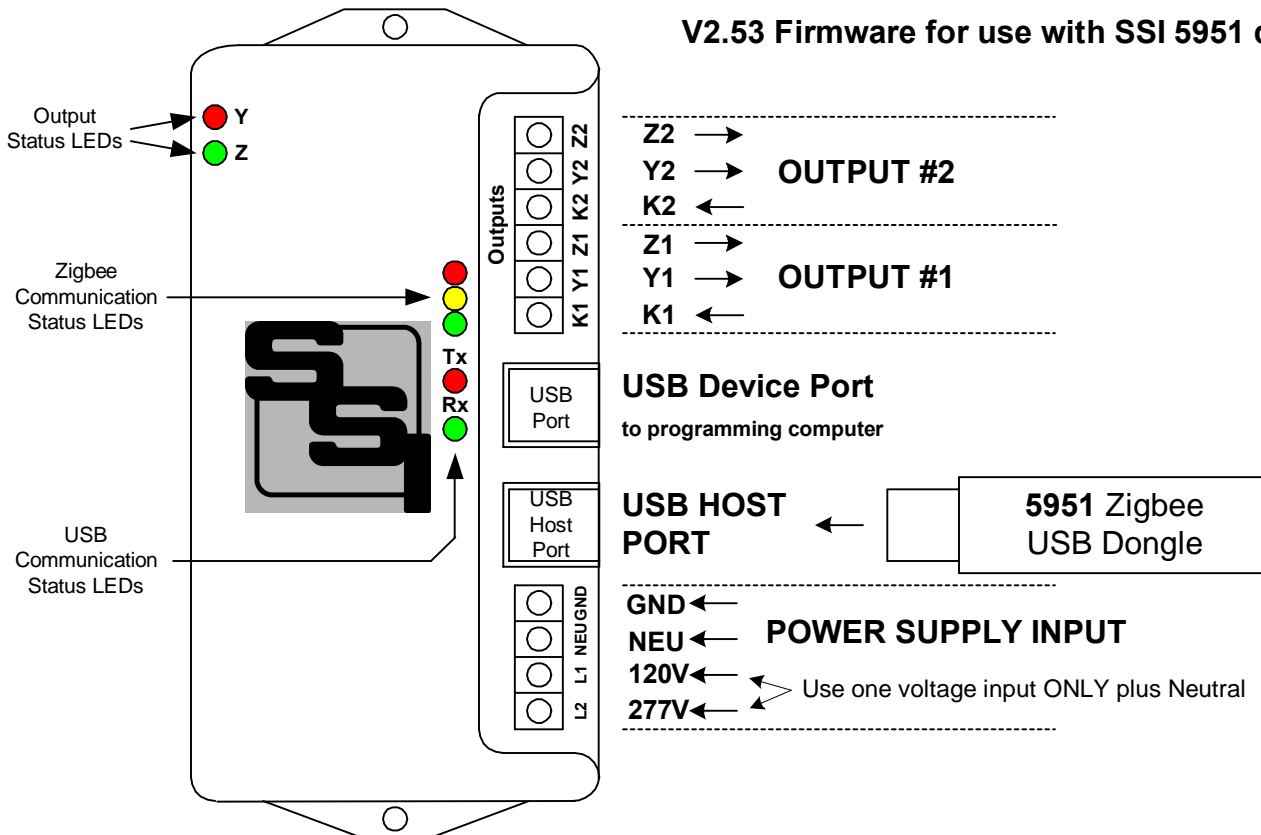

MOUNTING POSITION - The MPG-1C can be mounted in any position. Two mounting holes are provided. The MPG-1C must be mounted in a non-metallic enclosure or somewhere where it can receive wireless information from the meter without interference. The MPG-1C must be mounted within about 25 feet from a Zigbee-enabled meter. Distances vary with building construction and proximity to the meter. For best results, mount as close to the meter as possible. The pulse output lines from the MPG-1C may be run longer distances, but the MPG-1C should have an uninterrupted line-of-sight access to the greatest extent possible for best results. Choose a mounting location that will not have any metallic parts -- moving or stationary -- that can affect the RF field.

POWER INPUT - The MPG-1C is powered by an AC voltage of between 90 and 300 volts. For 120VAC, connect the AC supply's "hot" wire to the **L1** terminal. For 208 to 277VAC, connect the AC supply's "hot" wire to the **L2** terminal. Connect the **NEU** terminal to the AC supply's "neutral" wire. Connect **GND** to electrical system Ground. *** Use L1 or L2, but DO NOT use both at the same time.*** CAUTION: Wire Phase to Neutral, NOT Phase to Phase.

METER INPUT - The MPG-1C receives data from a Zigbee-equipped electric meter that has been paired with a Model 5951 Zigbee dongle. The USB dongle must be paired with the meter before it can be used. Once paired & inserted into the MPG-1C's host USB port, the MPG-1C starts receiving demand information from the meter.

OUTPUTS - Two 3-wire isolated outputs are provided on the MPG-1C, with output terminals K1, Y1 & Z1 and K2, Y2, & Z2. Transient suppression for the contacts of the solid-state relays is provided internally. The output loads should be limited to 100 mA at 120 VAC/VDC. Maximum power dissipation of each output is 800mW. The outputs are protected by fuses F1 & F2. One-tenth (1/10) Amp fuses (the maximum size) are supplied standard.

OPERATION - See the following pages for a full explanation of the operation of the MPG-1C.

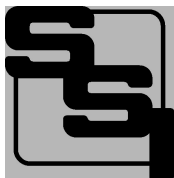

SOLID STATE INSTRUMENTS

a division of Brayden Automation Corp.

6230 Aviation Circle, Loveland, Colorado 80538

Phone: (970)461-9600 Fax: (970)461-9605

E-mail: support@solidstateinstruments.com

MPG-1C Wiring Diagram

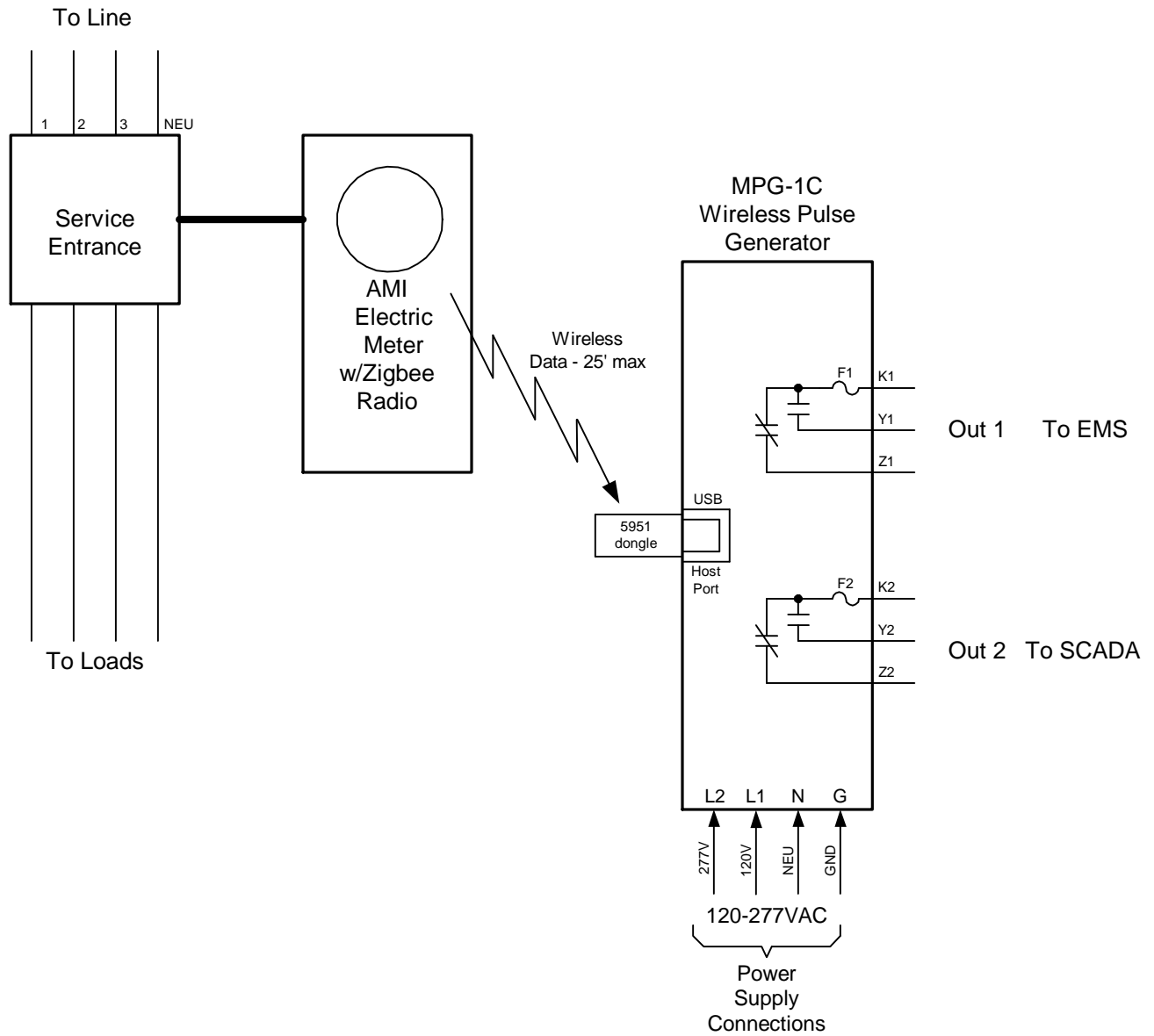

MPG-1CWiringDiagram.vsd

MPG-1C Wireless Pulse Generator Wiring Diagram		REVISIONS	
		NO.	DATE
DATE ORIGINAL 1/24/2020	SCALE N/A		
LATEST REVISION	JOB NO.	CHECKED	DRAWN WHB

**Brayden Automation Corp./
Solid State Instruments div.**
 6230 Aviation Circle
 Loveland, CO 80538
 (970)461-9600
 (970)461-9605 fax
www.solidstateinstruments.com

MPG-1C Wireless Meter Pulse Generator

Pairing the Zigbee Radio Receiver (dongle)

The USB Zigbee Receiver device or "dongle" that must be paired with a Zigbee-equipped AMI electric meter. This may be accomplished either with the assistance of the utility or on their website if they have the process automated. The pairing process, also known as "provisioning", varies from utility to utility and not all utilities provide Zigbee radio availability in their meters. Contact your electric utility to find out how their pairing process is accomplished. The dongle must be powered to be paired with the meter and must be within range of the meter, usually within 25 feet.

The Meter must be programmed with the dongle's MAC address and Installation ID code. By being "paired", the meter and the dongle have created a "network". The dongle(Client) knows that it can only receive and accept information from that particular electric meter(Server).

Before Powering the MPG-1C, install the dongle in the MPG-1C's USB [Type A] host port.

Power up the MPG-1C (This assumes that the utility has already sent the MAC address and Install ID to the meter.) Once the dongle has been inserted into the USB host port, power up the MPG-1C board. The LED on the dongle will flash once every 3 seconds indicating that it is scanning for a network to join. Once it has found a network, the LED on the dongle will flash twice a second indicating that it is pairing with the meter. Once it has completed establishing communications and created the network with the meter, the LED will stay on continuously. If this LED is not on continuously, the MPG-1C will not receive information from the dongle. If no valid communication is received from the dongle, the MPG-1C will reset it every 120 seconds (default reset time) trying to establish a connection. The LED on the dongle **MUST** be lit continuously before proceeding. If it is not solidly and continuously lit, then it is not provisioned correctly with the utility's meter. **Do not proceed until this step is successfully completed.**

Set the MPG-1C's Settings

Set the MPG-1C's output pulse value, the meter multiplier, the pulse mode and the pulse timing by using the USB [Type B] Device Port on the MPG-1C board. All system settings are now configured using the USB port. See "Setting up the Serial Port" on Page 5.

Output Pulse Value

The Output Pulse Value is set using the **P** command. The pulse value (PV) is the number of watt-hours (not kilowatt-hours) that each pulse is worth. The MPG-1C can be set from 1 Wh to 99999 Wh per pulse. Select an appropriate pulse value for your application. A good starting point is 100 Wh/pulse for larger buildings and 10 Wh/pulse for smaller buildings. You can adjust it up or down as needed. Larger facilities will require a larger pulse value to keep from overranging the MPG-1C's registers.

Set the Output Pulse Mode

The MPG-1C has two output pulse modes, the 3-Wire (Form C) **Toggle** mode or the 2-Wire (Form A) **Fixed** mode. Use the **C1** command to select the FORM C Toggle mode. The toggle mode is the classic pulse output mode that emulates the standard KYZ 3-Wire electric meter output. It toggles back and forth, to the opposite state, each time a "pulse" is generated by the MPG-1C. Even though there are three wires (K,Y, & Z), it is common to use K and Y, or K and Z, for many two-wire systems that require or desire a generally symmetrical 50/50 duty cycle pulse at any given time. The toggle mode is used for systems that are doing demand monitoring and control and need regularly spaced or "symmetrical" pulses. If you are in FORM C Toggle output pulse mode, and your pulse receiving device uses only two wires, and the pulse receiving device only counts the closure as a pulse(not the opening also), then the 3-Wire pulse value must be doubled in the Pulse Receiving Device. Red and Green Output LEDs show the output status. See additional information on Page 5.

Use the **C0** command to select the FORM A **Fixed** mode. In the Fixed mode, only the K-Y output is used. This is the standard 2-Wire system where the output contact is normally-open until such time as a pulse is generated. When a pulse is generated, the contact is closed for a selected fixed time interval in milliseconds. Form A mode is generally associated with Energy (kWh) measuring or counting systems that dont need a symmetrical pulse.

Set the Fixed Mode Output Pulse Width (Closure Time)

If you are using the MPG-1C in the Fixed Mode, set the output closure time or pulse width, selectable at 25ms, 50mS, 100mS, 200mS, 500mS or 1000mS (1 second) using the **W** command.(See Page 10) Upon a pulse being generated, the K-Y terminals of each output will close for the selected number of milliseconds and light the RED Output LED only. This setting applies only to the Form A output mode, and does not affect the toggle output mode. Use the shortest closure time possible that will be reliably received by the pulse receiving equipment, so as not to unnecessarily limit the output's pulse rate. Form A pulses occur simultaneously on both output channels.

MPG-1C Wireless Meter Pulse Generator (con't)

Communication LEDs

Upon power-up, the YELLOW comm LED should light indicating that the dongle is correctly inserted, initialized and communicating with the MPG-1C's processor. Within about approximately 45 - 60 seconds, the GREEN comm LED will blink each time a valid transmission is received from the meter. As long as valid meter transmissions are received by the dongle and successfully relayed to the MPG-1C's processor, the Green comm LED will blink about once every 8-9 seconds. If the Green comm LED does not blink, that is an indication that the data transmissions from the meter are not being received, may be corrupted, or in some manner are not valid transmissions. If the Green comm LED has been blinking reliably every 8-9 seconds for some time, then stops for a while and then restarts again, this indicates that transmissions are intermittent and sporadic, or generally means there is a problem in the dongle's ability to receive data reliably from the meter. To correct this, change the proximity of the MPG-1C to the meter, move it closer to the meter if possible and eliminate any metallic obstructions between the meter and the MPG-1C. Also check to make sure that any walls or barriers between the MPG-1C and the meter have as little metal in them as possible. In some applications you may need line-of-sight.

Pulse Outputs

Outputs can be configured to be in the **Toggle** (Form C) mode or the **Fixed** (Form A) mode. Generally speaking, the Form C mode can be used with either 2-Wire or 3-Wire Pulse receiving devices, while the Form A mode uses only a 2-Wire interface to the downstream (receiving) pulse device. The choice would depend on the application and the desired pulse format that the receiving device prefers to see.

If the dongle is reliably receiving data from the meter and passing it on to the MPG-1C's processor, then you should see the Red and Green output LED's toggle each time the selected pulse value is reached, and the processor generates a pulse. If the pulse output value is too high and pulses are too slow, then select a lower pulse value using the **P** command.

If pulses are being generated too rapidly, select a higher pulse output value using the **P** command. The maximum number of pulses per second in the toggle mode is approximately 10, which means that the output's open and closed times are about 50mS each in toggle mode. If the calculation by the MPG-1C's processor for pulse output timing exceeds 15 pulses per second, the MPG-1C will light the RED comm LED, indicating an overflow error, and that the pulse value is too small. It is "latched" on so that the next time you look at it this RED LED will be lit. In this way, you can quickly determine if a pulse output value is too small. In the optimum application, pulses would not exceed more than one pulse per second at full scale demand. This allows a very even and "normal" pulse rate that as closely as possible resembles an actual KYZ pulse output from the meter.

The MPG-1C will "spread out" the pulses over the next 10 second period if a high enough watt-hour value is received in a transmission to require that more than one pulse is generated. For example, suppose you've selected an Output Pulse Value of 10 wh. The next 8-second transmission yields 24 wh have been used. Since 24 watt-hours exceeds the 10 watt-hour setting, two pulses must be generated. The first 10wh pulse will be generated immediately. About 3-5 seconds later the second 10wh pulse will be generated. The remainder of four watt-hours stays in the accumulated energy register (AER) awaiting the next transmission and the energy value of that transmission to be added to the contents of the AER. Another example: Assume 25 wh/p Output Pulse Value. Let's say the next transmission is for 130 watt-hours. 130 is greater than 25, so 5 pulses will be outputted over the next 7 seconds, approximately one each 1.4 seconds ($7 \text{ seconds} / 5 = 1.4 \text{ seconds}$). The remainder of 5 wh will stay in the AER awaiting the next transmission. Some trial and error may have to be done for any particular building since pulse rates will change depending on maximum load.

Overranging the Output

As previously mentioned, if there are too many pulses calculated to be outputted in a 6-7 second interval than the MPG-1C can generate given the timing constraints, the MPG-1C will light the RED Comm LED. In this situation, simply increase the output pulse value using the **P** command, making the value larger and the speed of pulses slower. This LED is intended to notify the user that some pulses have been lost and a larger pulse value is needed. As load is added to a building over time, there is a greater likelihood that this may occur, especially if the pulse output value is small. Be sure to consider this if/when you add load to the building. If an error condition occurs, set the Output Pulse Value for a Wh value that is double the current pulse value. Remember to change the pulse constant of your receiving device as well, since pulses will now be worth twice the value. Cycle power to the MPG-1C to reset the RED Comm LED after increasing the pulse value.

WORKING WITH THE MPG-1C RELAY

OPERATING MODES: The MPG-1C Meter Pulse Generator allows the outputs to be configured in either the "Toggle" or "Fixed" pulse output mode. In the Toggle mode, the outputs alternate or toggle back and forth each time a pulse is generated. This is synonymous with the classic 3-Wire Pulse metering and emulates the SPDT switch model. Figure 1 below shows the timing diagram for the "Toggle" output mode. KY and KZ closures or continuity are always opposite of each other. In other words, when the KY terminals are closed (on), the KZ terminals are open(off). This mode is best for timing pulses to derive demand whether 2 or 3 wires are being used.

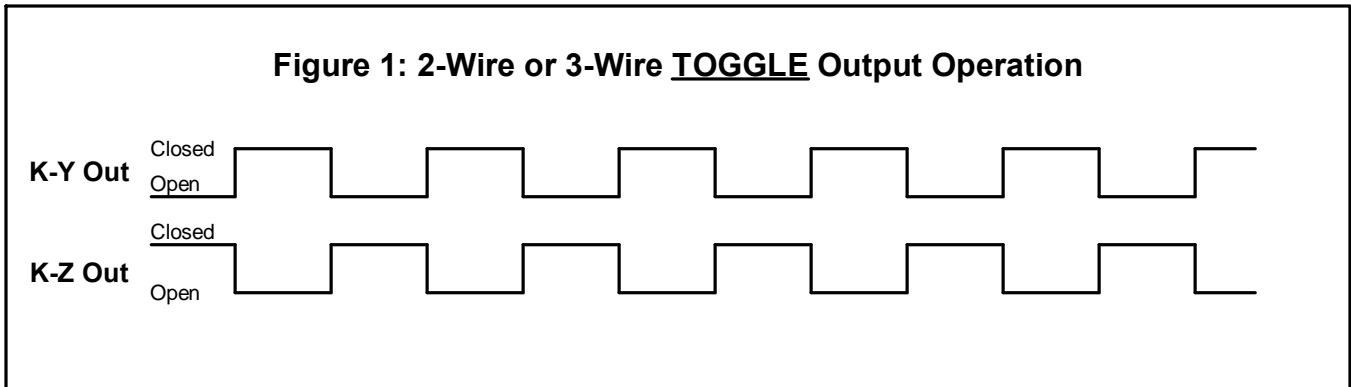

In the Fixed output mode, shown in Figure 2 below, an output pulse (K-Y closure only) is a fixed width (T1) each time the output is triggered. The pulse width (closure time) is determined by the setting of the W command. This mode is best for energy (kWh) counting systems but is generally not the best for systems doing demand control where pulses are timed to derive instantaneous kW demand. The K-Z output is not used in the normal/fixed mode. However, it is used in the Signed mode. See Page 6.

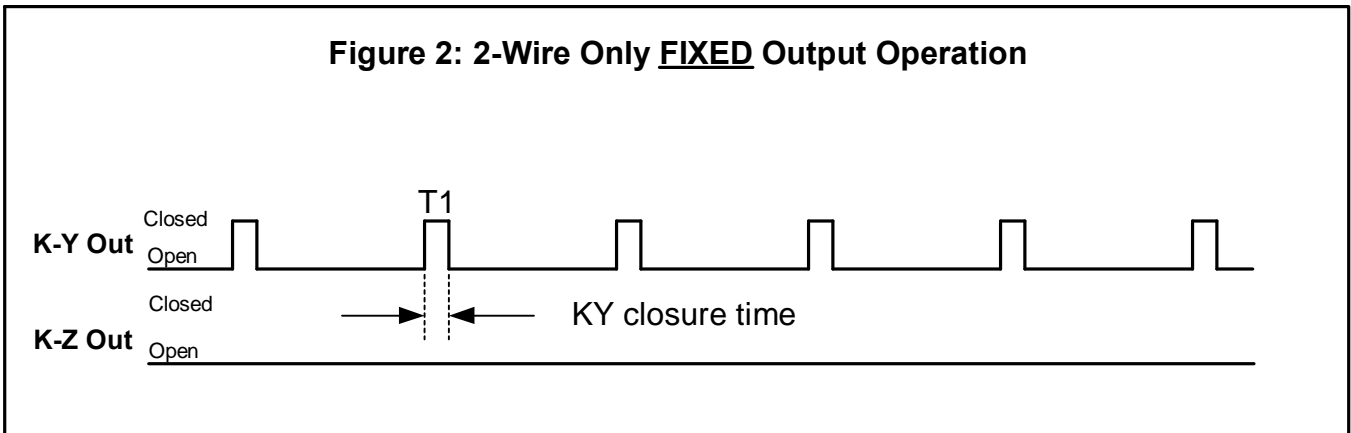

In Signed mode, with a Form A output mode selected, the K-Z output pulse represents negative (or *kWh Received*) energy. (See Page 6.)

Contact the factory for technical support at (970)461-9600.

MPG-1C Programming

Meter Multiplier

If the building on which you are using the MPG-1C has an "Instrument-Rated" electric meter, AND the local utility has not included this multiplier in the programming of the meter, you will have to enter the Meter Multiplier to the MPG-1C's program. To check out whether or not this is needed, (assuming your dongle is paired with the electric meter) either install the dongle on a computer in the building and look at the serial output using a terminal program, or hook up the MPG-1C's serial port to a computer and view with a terminal program.

Determine the Multiplier of the facility's electric meter. If the meter is a self-contained meter, the multiplier is 1. The default external multiplier setting in the MPG-1C is one (1), so you can skip this step. In an instrument-rated metering configuration, the meter multiplier is normally the Current Transformer ("CT") ratio, but will also include the Potential Transformer ("PT") Ratio, if PT's are used, usually only on larger applications. A 800 Amp to 5 Amp current transformer, for example, has a ratio of 160. Therefore, the meter multiplier on a building with 800:5A CT's would be 160. The Multiplier is normally printed on the monthly utility bill and may also be written on the meter face. If you cannot find it, call your utility and ask what the meter or billing multiplier is.

If the utility's Zigbee transmission to the dongle includes the correct CT/PT multiplier value, you can skip this step also. This is very rare on instrument-rated metering implementations however, since most utilities do not want to program the multiplier into the meter due to conflicts with the billing process. If you are looking at the serial data received from the meter you will be able to see what internal multiplier is being sent in every transmission. This will be in hexadecimal format. What you're looking for is whether this is 1 or something besides one. If, for instance, the multiplier is a decimal 160, it will be transmitted by the meter to the dongle as a hexadecimal "A0". If the multiplier is one(1), you then know that either this is a self-contained meter and a multiplier of 1 is correct, OR that this is an instrument-rated meter and the utility does NOT send the CT/PT multiplier as part of the Zigbee transmission. If the latter is true, (**and this is the standard**), you will have to program the meter multiplier into the MPG-1C.

Setting up the Serial Port

Connect the USB A-B Type serial cable to the computer's USB port. Connect the other end to the MPG-1C's USB Type B connector. With TeraTerm, Puddy, ProComm or some similar terminal program, select the correct COM port to be used, set the baud rate at **57600** and the terminal mode Receive as CR+LF. Also make sure that the local echo is enabled or "ON". Alternately, download the **SSI Universal Programmer** from the MPG-1C Downloads page on solidstateinstruments.com.

Turn on power to the MPG-1C and after the initialization process, the LED on the dongle should be lit continuously. Assuming that the dongle is paired with the meter, is on, and is within 75' of the meter, then every 8 to 10 seconds, you will see the following serial information received from the MPG-1C:

```
-----  
Time Stamp: 21582e64 TSN:N  
Demand: 000967  
Multiplier: 00000001  
Divisor: 000003e8  
Energy (U): 5.35 Wh
```

If the multiplier coming from the meter is 1 AND you know that the meter's multiplier is something other than one, you will have to program the correct meter multiplier into the MPG-1C so that the true energy value is correct.

Programming the Multiplier

To change the multiplier in the MPG-1C, use the **M** command. Enter M160 and press <Enter> to change the multiplier to 160, as outlined in the application above. The USB serial link to the MPG-1C will return:

```
-----  
Multiplier: 160  
-----
```

You will not see the "M160" that you typed in on the screen unless the local echo is enabled on your terminal software. To read back what the value of the multiplier currently in the MPG-1C is, press R and <Enter>. The USB serial link will return the current multiplier stored in the MPG-1C, along with all other system settings. For example, "Multiplier = 40" will be returned if the current multiplier is 40. Case does not matter. The maximum multiplier is 99999 and must be an integer (whole) number.

The USB serial port is used for both monitoring and programming the MPG-1C. Therefore you have to enter your data between 8-second serial outputs from the MPG-1C.

MPG-1C Programming(cont)

Programmable Output Pulse Value

To set the Output Pulse Value, use the P command with a value of 1 to 99999. The default value of this register is ten (10) watt-hours per pulse.

Hook up the MPG-1C's USB device port to a computer and use a terminal program to program a pulse value. (See "Setting up the Serial Port" on the previous page.

Programming the Output Pulse Value with a Specific Value

To change the output pulse value in the MPG-1C, use the **P** command. Enter P1440 and press <Enter> for example to change the output pulse value to 1440 watt-hours or 1.44 kWh per pulse. The maximum value is 99999. The USB serial link to the MPG-1C will return:

Pulse Value: 1440 watthours

indicating that the value is 1440 watt-hours (1.44kWh) .

Reading back all Programmable Parameters

To view the values of all programmable settings that are currently programmed into the MPG-1C, press **R** and <Enter>. The USB serial link will return the following values programmed into the MPG-1C or current data values:

Multiplier: 300
Pulse Value: 1440 Watt-hours
Output Mode: Normal
Output Form: C
Dongle Mode: Normal
Reset Time: 120 seconds
End of Interval: 1000ms
Interval Every: 15 min.
08/09/19 03:13:19 DOW:6

Set Factory Defaults

If you find that you want to reset all parameters back to the factory defaults, simply press the **Z** key and <Enter>. The following parameters will default back to the factory settings as follows:

Multiplier=1
Pulse Value: 10 Wh

Viewing the Firmware Version

To view the version of firmware in the MPG-1C use the "V" command. Press V or v, then <Enter>and the serial link will return the following:

MPG V2.53

Dongle Readout Mode

There are three dongle readout modes available on the MPG-1C with V2.51 firmware are Normal,Echo. and Energy Adjustment. The Normal Mode is the default and shows you the time stamp, the demand, the multiplier and the divisor coming from the meter. The Normal mode is set by entering D1 followed by <Enter>.

Dongle Model: Normal

The Echo mode allows you to view the entire transmission coming from the meter the way it is received by the MPG-1C's microcontroller from the dongle in XML format. This mode may be useful in troubleshooting in the event of intermittent transmissions from the meter. Enter a D2 followed by <Enter> to put the MPG-1C into the Dongle Echo mode.

The serial link will respond with:

Dongle Model: Echo

The Energy Adjustment mode (d8) which only shows energy adjustments when they occur.

MPG-1C Programming (cont)

Bi-Directional Energy Flow (Signed Mode)

If you have energy flowing in both directions in the case of distributed energy resources (solar, wind, etc), the MPG-1C can provide both positive and negative pulses. This is known as the **Signed** mode, meaning that "kWh Delivered" (*from* the utility *to* the customer) is positive or forward flow, and "kWh Received" (*from* the customer *to* the utility) is negative or reverse flow. The Pulse Value Setting is the same for both positive and negative values.

To enter the functional or operational mode into the MPG-1C, use the **S0** and **S1** commands. Press S0 <Enter> to set the MPG-1C in the Normal mode. Press S1 <Enter> to set the MPG-1C in the Signed mode. The serial link to the MPG-1C will return "Output Mode: Signed". To read what mode the MPG-1C is currently in, press R <Enter>. The serial link will return the mode stored in the MPG-1C. For example, "Output Mode: Normal" will be returned. Case does not matter.

Form C Signed mode - A positive energy value received from the meter is added to the positive Accumulated Energy Register(+AER). Negative energy values received are ignored. Only Form C toggle pulses are generated on the KYZ output for Positive energy flow. See Figure 3 below.

Form A Signed mode - A positive energy value received is added to the positive Accumulated Energy Register(+AER). A negative energy value received is added to the negative Accumulated Energy Register(-AER). When either register equals or exceeds the Pulse Value setting, a pulse of the corresponding sign is outputted on the correct line. Pulses in this mode are Form A (2-wire) "Fixed" only. K-Y pulses are positive pulses and K-Z pulses are negative pulses. They share a common K terminal on the output. Set the pulse value using the **P** command. Set the pulse width using the **W** command. See Figure 4 below.

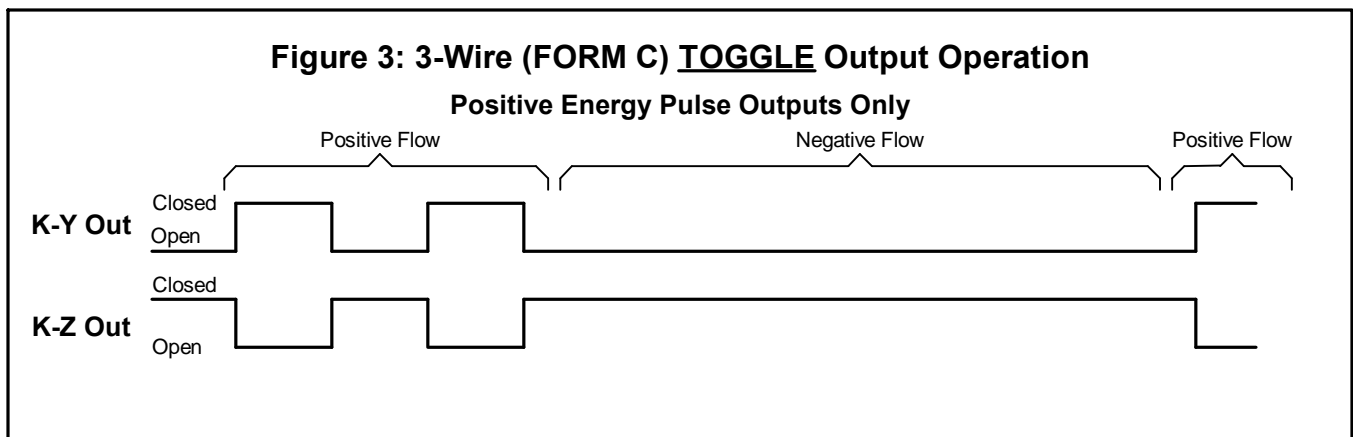

In Signed mode, with a Form C output mode selected, the K-Y and K-Z output pulses represent positive (or kWh Delivered) energy; Negative (or kWh Received) energy is ignored.

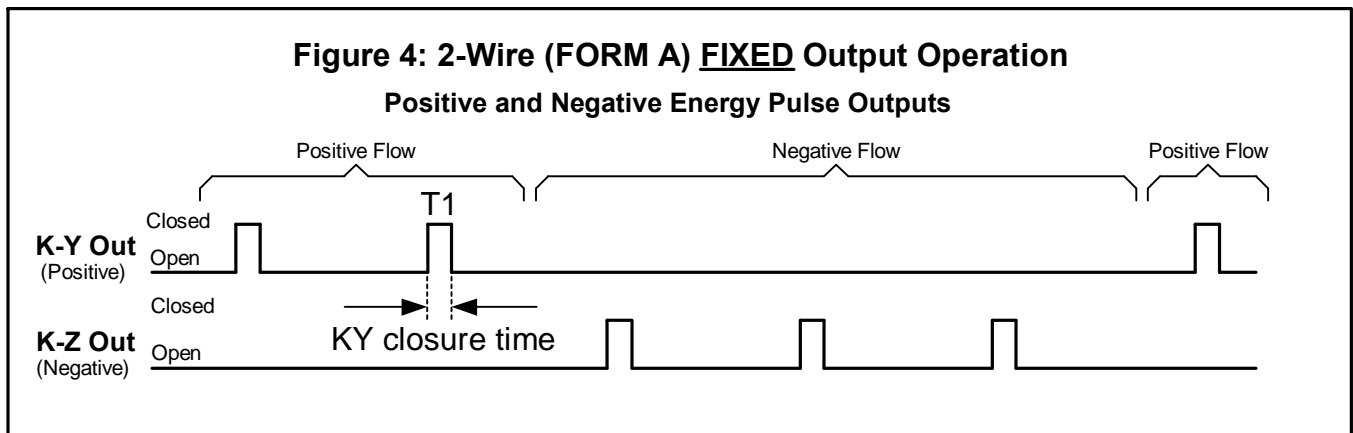

In Signed mode, with a Form A output mode selected, the K-Y output pulse represents positive (or kWh Delivered) energy; K-Z output pulse represents negative (or kWh Received) energy.

Energy Adjustment Mode Enable/Disable (A)

The MPG-1C includes an energy adjustment mode to validate the energy represented by number and value of output pulses against the accumulated energy from the electric meter. This mode automatically adjusts the AER positive or negative, each time the energy summation register of the meter changes. In this way, the number and value of the pulses being outputted from the MPG-1C will always directly match the energy that the meter is reporting has been consumed.

To enable the Energy Adjustment mode enter Ax and <ENTER>. x is 1 for enabled and 0 is disabled. The default is 1. Enter A1, and <ENTER> and the EA mode is enabled. The serial link on the MPG-1C will return the following:

Energy Adj: Enabled

To disable the filter mode enter A0 and <ENTER>. The serial link on the MPG-1C will return the following:

Energy Adj: Disabled

Odometer Reset

The MPG-1C also contains diagnostic odometers which track the total energy of all pulses outputted by both output channels. This can be reset using the "O0" command. Enter O0 and press <ENTER> and the odometers are reset to zero.

Factory ("Hard") Reset of Dongle

The MPG-1C's 5951 dongle may be completely reset if necessary. This is generally known as a factory or "hard" reset and completely disassociates the dongle from the meter. Once the dongle is reset all provisioning information that was stored is lost and the dongle must be provisioned or paired with an electric meter again. If you are moving your MPG-1C to another location (that has a different meter) or if the electric meter has been changed in the current location, a factory reset must be performed before the 5951 dongle can be provisioned with another meter or re-provisioned with the current meter.

To do a hard reset on the 5951 Dongle:

- 1.) Press and hold the button on the side of the dongle until the Green LED begins to blink rapidly.
- 2.) Release button.
- 3.) Within 2 seconds, press and hold the button down for 5 seconds again, until both LEDs turn off.
- 4.) Release button.
- 5.) If the factory reset was successful, the RED LED should be off and blink once every 3 seconds to indicate that it is scanning for a network to join.

You can also accomplish the hard reset on the dongle by using the **SSI Universal Programmer** software.

WARNING: A hard reset of the dongle will completely disconnect the dongle from the meter, and would have to be re-provisioned with the meter.

List of MPG-1C Commands (?)

For help in selecting or using the serial commands with the MPG-1C, simply press the ? key. The serial link on the MPG-1C will return a full list of the commands.

'mXXXXX<CR>' or 'MXXXXX<CR>' - Set multiplier (XXXXX is 1 to 99999).
'pXXXXX<CR>' or 'PXXXXX<CR>' - Set pulse value, Watt-hours (XXXXX is 0 to 99999)
'a0<CR>' or 'A0<CR>' - Disable Energy Adjustment mode
'a1<CR>' or 'A1<CR>' - Enable Energy Adjustment mode
'r<CR>' or 'R<CR>' - Read Parameters.
's0<CR>' or 'S0<CR>' - Set into Normal mode (positive only with Form A or C set by DIP4)
's1<CR>' or 'S1<CR>' - Set into Signed mode (positive/negative with only Form A)
'd0<CR>' or 'D0<CR>' - Disable Dongle mode
'd1<CR>' or 'D1<CR>' - Set into Dongle Normal mode
'd2<CR>' or 'D2<CR>' - Set into Dongle Echo mode
'd8<CR>' or 'D2<CR>' - Set into Energy Adjustment mode (reports adjustments only)
'eX<CR>' or 'EX<CR>' - Set End Of Interval, (X is 0-8), 0-Disabled. (This feature not supported on MPG-1C.)
'iX<CR>' or 'IX<CR>' - Set Interval Length, (X is 1-6) (This feature not supported on MPG-1C.)
'KMODYYRHRMNSC<CR>' - Set Real Time Clock Calendar, MO-Month, DY-Day, etc.. (This feature not supported on MPG-1C.)
'z<CR>' or 'Z<CR>' - Set Factory Defaults
'v<CR>' or 'V<CR>' - Query Firmware version

Pulse Output Mode (Form)

'c0<CR>' or 'C0<CR>' - Pulse Output Mode Form C Disabled (Form A Output Mode)
'c1<CR>' or 'C1<CR>' - Pulse Output Mode Form C Enabled (Form C Output Mode) (default)

Form A Pulse Width

'wX<CR>' or 'WX<CR>' - Pulse Width in Form A mode, milliseconds - 25 to 1000mS, 100mS (W2) default;

Form A Pulse Width Selections:

'w0<CR>' or 'W0<CR>' - 25mS Closure
'w1<CR>' or 'W1<CR>' - 50mS Closure
'w2<CR>' or 'W2<CR>' - 100mS Closure
'w3<CR>' or 'W3<CR>' - 200mS Closure
'w4<CR>' or 'W4<CR>' - 500mS Closure
'w5<CR>' or 'W5<CR>' - 1000mS Closure