

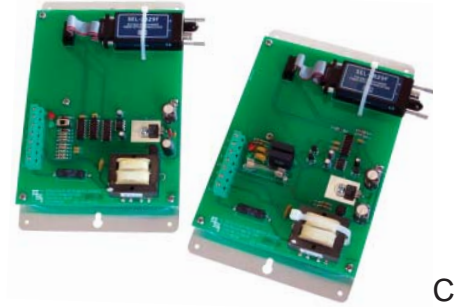

PULSE LINKS

# OPL-1B OPTICAL FIBER PULSE LINK

## DESCRIPTION



The OPL-1B optical fiber pulse link system is a transmitter/receiver pair that uses fiber optic cable to send metering pulses over long distances. The OPL-1B can receive and transmit pulses over distances up to approximately 68 miles. The output is configured as a Form C, but can be used as a Form A (2-wire) or a Form C (3-wire) depending on the transmitter's input configuration selection. This system makes it possible to quickly implement an optical pulse link with minimal effort and includes all power supplies, wetting voltages, isolation relays and connectors.

Each system consists of an OPT-1B transmitter and an OPR-1B receiver. The OPT-1B transmitter is designed to receive pulses from an electric meter's KYZ pulse initiator. Pulses are conditioned and sent by fiber optic cable to an OPR-1B receiver where the pulse information is validated and implemented into the correct pulse state. The OPT-1B transmitter and OPR-1B receiver must be paired and cannot be used independently. Fiber optic cable not included.

Bright red and green LEDs monitor the input status on the OPT-1B transmitter and provide easy and immediate visual system checking without test equipment. A selector switch allows selection of Form A (2-wire) or Form C (3-wire) input configuration.

The OPR-1B receiver also includes bright red LEDs to monitor the K-Y output status. The dry contact output features a 1/4 amp solid-state relay for a no-bounce contact with internal MOV transient suppression circuitry to eliminate contact noise. Rapid pulse rates in excess of 20 pulses per second are possible.

Both the OPT-1B transmitter and OPR-1B receiver come standard mounted on a .062" aluminum base plate with mounting tabs and keyhole mounting slot, intended for mounting in another control equipment enclosure. Each unit weighs approximately 2 pounds and can be mounted in any position. NEMA 4X rain-tight enclosures are available for both the transmitter and receiver units.

The standard OPL-1B is a multi-mode fiber system. A single mode fiber OPL-1B system is available by special order. Contact the factory for current pricing.

OPT-1B FUNCTIONAL SUMMARY

	IN	OUT
#	1	1
TYPE	2 or 3 Wire	Optical Fiber
FORM	A or C	-

OPR-1B FUNCTIONAL SUMMARY

	IN	OUT
#	1	1
TYPE	Optical Fiber	2 or 3 Wire
FORM	-	C

# OPL-1B

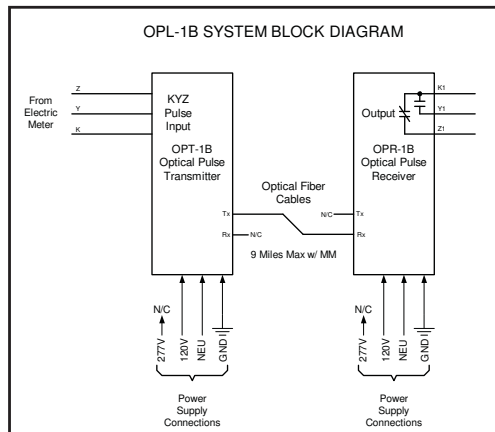



## PULSE LINKS

# OPL-1B OPTICAL FIBER PULSE LINK

## SPECIFICATIONS

### ELECTRICAL

Power Input:	120, 208-277 VAC. Burden: 3.5 VA
Signal Input:	Optical fiber input from OPT-1B transmitter; One Form C (K,Y, & Z) input from the sending device to the OPT-1B transmitter
Output:	One Form C (K,Y & Z) solid state, dry contact output from the OPR-1B receiver
Maximum Pulse Rate:	OPR-1B: >40 Pulses per second (Form C), 20 pulses per second (Form A) OPT-1B: >200 Pulses per second (Form C), 100 pulses per second (Form A)
Maximum Output Voltage:	250 VAC
Maximum Output Current:	1/4 Amp
Maximum Power Rating:	25 VA
Sense Voltage:	+13VDC provided to the sending device(s)
Contact On-State Resistance:	5 ohms maximum, 3 ohms typical
Switching Time:	Turn On: 8 milliseconds typical Turn Off: 1 milliseconds typical
Input/Output Isolation Voltage:	2500Vrms (of relay alone)

### MECHANICAL

Mounting:	Any position.
Size:	5.5" wide, 9.5" high, 3.5" deep
Weight:	2 pounds

### TEMPERATURE

Temperature Range:	-38° C to +70° C, -36.4° F to +158° F
Humidity:	0 to 98% non-condensing

### AVAILABLE OPTIONS

Input Voltages:	Contact Factory
Enclosure:	NEMA 4X rain-tight and dust-proof enclosure available. 12.0" high, 10.0" wide, 6.0" deep
Fiber:	Long distance single-mode model available by special order

# OPL-1B