

OPR-4C

OPTICAL FIBER PULSE RECEIVER INSTRUCTION SHEET

Elite Solid State

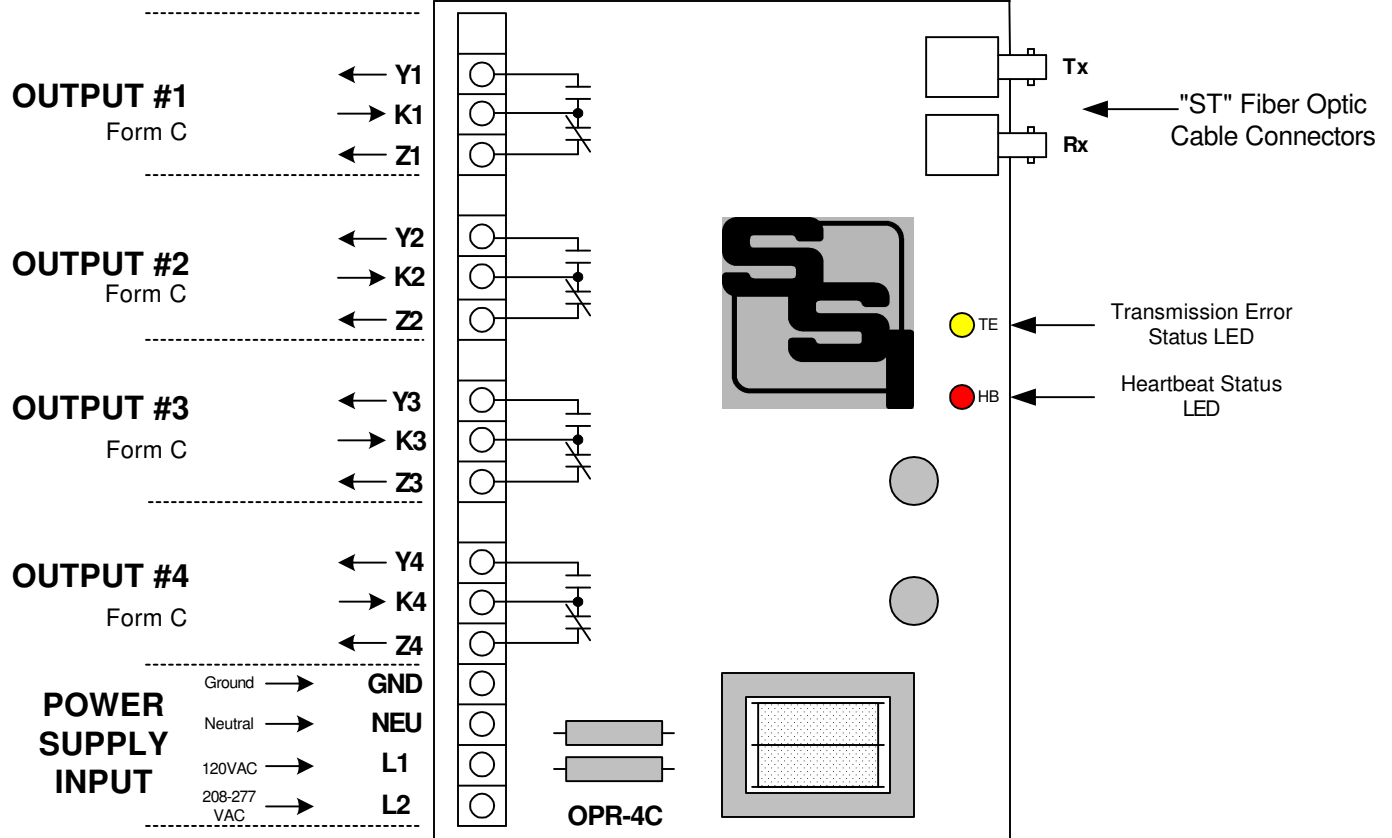

MOUNTING POSITION - The OPR-4C may be mounted in any position.

POWER INPUT - The OPR-4C can be powered by 120VAC or 208 to 277VAC. Connect the **GND** terminal to the electrical system ground. Connect the Neutral lead to the **NEU** terminal. Connect the **L1** terminal to the 120VAC "Hot" lead for 120VAC operation. Connect the **L2** terminal to the 208, 240, or 277 "Hot" lead. **Do not use both L1 and L2. Exercise caution when board is energized. There is voltage present at L1 and L2 when powered.**

RELAY OUTPUTS - The OPR-4C has four KYZ pulse outputs, that can be used as either 2-Wire (Form A) or 3-Wire (Form C). Outputs are K1,Y1, & Z1 for output #1; K2,Y2, & Z2 for output #2; K3,Y3, & Z3 for output #3; and K4,Y4, & Z4 for output #4. For 2-Wire mode, the K & Y or the K & Z terminals may be used. For 3-Wire mode, all three wires must be used. Relay outputs are electrical isolated, solid-state dry-contact type with NO sourced voltage. The user must supply their own wetting voltage.

GROUND - The GND terminal on the OPR-4C is a common ground with the chassis and is connected to the Chassis by means of the lower left-hand mounting screw. Therefore, if necessary, the electrical system ground can be connected to the OPR's chassis. Do not tie the Ground and Neutral terminals together.



SOLID STATE INSTRUMENTS

a division of Brayden Automation Corp.

6230 Aviation Circle, Loveland Colorado 80538

Phone: (970)461-9600 Fax: (970)461-9605

E-mail: support@solidstateinstruments.com

INSTRUCTION SHEET

OPR-4C OPTICAL FIBER PULSE RECEIVER (con't)

Fiber Optic Cable Connections - Locate the two "ST" fiber optic ports in the upper right-hand corner of the OPR-4C receiver module. Connect the fiber optic cable to these ports using the twist lock connections. The cables should be "crossed" such that each cable is connected to the "Tx" fiber optic port on one end and the "Rx" fiber optic port on the other end. See the System Block Diagram below.

The OPR-4C will receive pulse information from the OPT-4C Optical Fiber Pulse Transmitter up to approximately 2500 meters or about 1.5 miles using multimode fiber. Care should be taken to follow all proper fiber optical cable implementation standards. Maximum distance will vary with the quality of the multimode fiber.

Troubleshooting - LED Status Lights - The OPR-4C has two status lights to help the installer determine system status.

Red "Heartbeat" LED (HB) - This LED blinks on and off once per second indicating the system is operating and the microcontroller is going through its program loop. There is no other meaning to this except that the system is alive and running, and appears to be operating normally.

Yellow "Transmission Error" LED (TE) - This LED will light if the microcontroller receives one or more communication packets from the OPT-8C Transmitter that contain errors or that has incorrect information.

OPL-4C SYSTEM BLOCK DIAGRAM

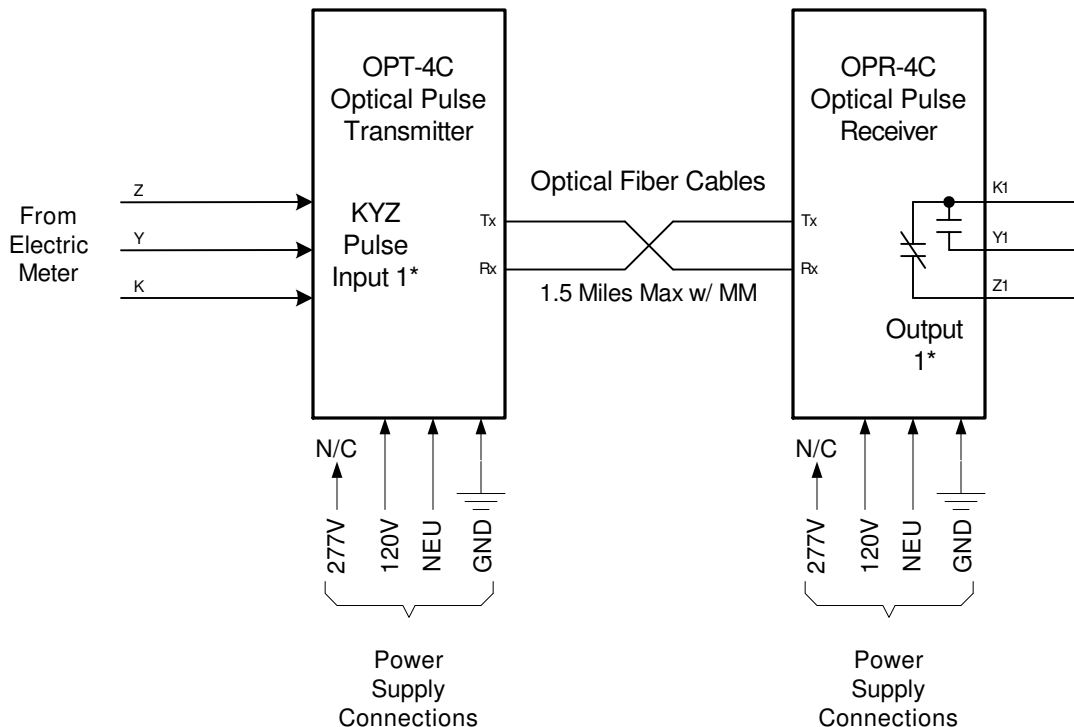

* Only 1 input/Output Circuit Shown

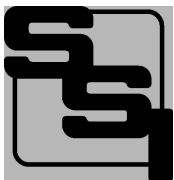

SOLID STATE INSTRUMENTS

a division of Brayden Automation Corp.

6230 Aviation Circle, Loveland Colorado 80538

Phone: (970)461-9600 Fax: (970)461-9605

E-mail: support@solidstateinstruments.com