

INSTRUCTION SHEET

CIR-22A CUSTOMER INTERFACE RELAY

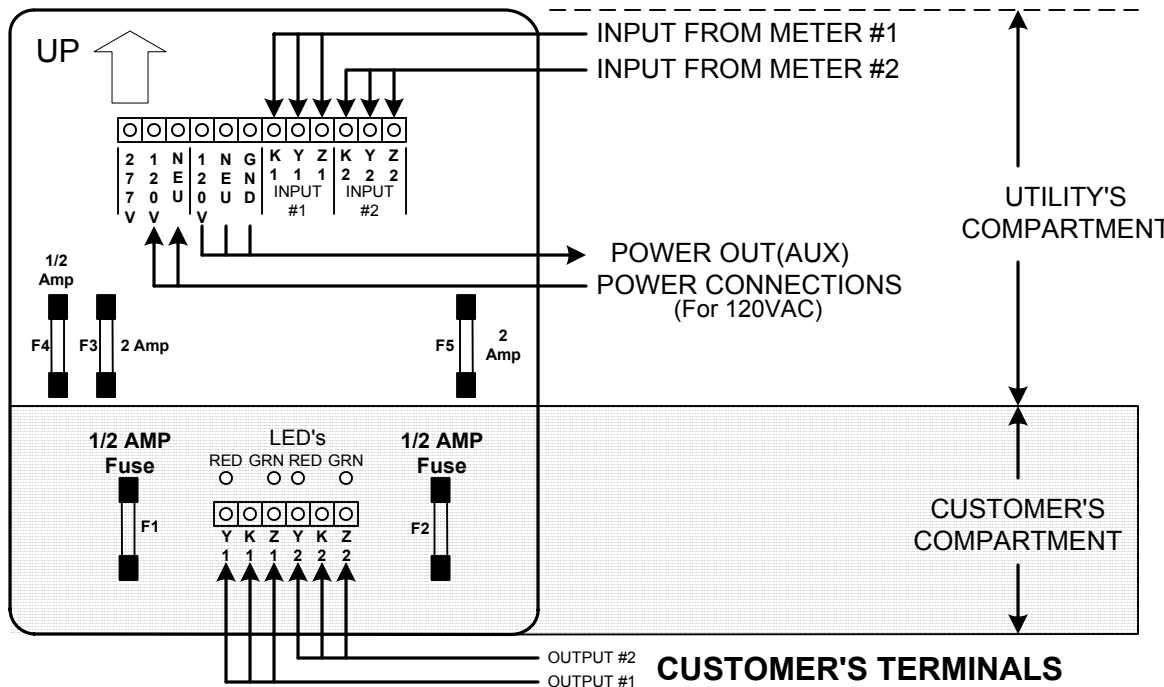

MOUNTING POSITION - Because the CIR-22A contains mercury-wetted relays, it must be mounted in a vertical position to operate correctly.

POWER INPUT - If the CIR-22A is to be powered by a local power supply of between 90 and 200 volts, use the NEU and the 120V input terminals in the utility's compartment. For 200 to 350 VAC operation, use the NEU and 277V input terminals in the utility's compartment.

METER CONNECTIONS - Connect the K, Y, & Z leads from Meter #1 to the K1, Y1, & Z1 input terminals on the terminal strip in the utility's compartment. Connect Meter #2 to K2, Y2 and Z2 input terminals of Input #2. The CIR-22A's "K" terminal provides a common return (system ground). The Y and Z input terminals provide a "pulled up" sense voltage of +13VDC to the meters' "Y" and "Z" terminals. The CIR-22A is designed for 3-Wire Form C inputs use only. The CIR-22A's KYZ inputs are compatible with electromechanical or solid state pulse initiators. When using an open-collector transistor output or open-drain FET to interface a meter with the CIR-22A, the transistor's emitter or the FET's drain must be connected to the K input terminal. The transistor's collector or the FET's source pin must be connected to the Y or Z input terminals.

CUSTOMER OUTPUTS - Two outputs are provided for customer use, one corresponding to each input. The output terminals are located in the bottom of the enclosure in the customer compartment and are marked K1, Y1 and Z1 for the first output and K2, Y2, and Z2 for the second output. Each K-Y input (connection) will cause a K-Y output of the same channel. A K-Z input (connection) will result in a K-Z output. Outputs are dry-contact type and must be provided with an external voltage of up to 250VAC/VDC on the K terminal by the customer's equipment. Arc suppression for the contacts of the mercury-wetted relays are provided internally.

FUSES - Fuse F3 in the utility's compartment is coordinated with the customer's fuse F1. Normally a 2 Amp fuse is used for F3 and a 1/2 Amp fuse is used for F1. Fuses F2 & F5 are similarly coordinated with F2 being 1/2 Amp and F5 provided at 2 amps. F3 and F5 are designed to protect the CIR-22A's circuit boards in the event that larger than fuses larger than 2 amps are used in the F1 and F2 positions. F1 and F2 may be sized from 1/4 Amp to 2 Amp, depending on customer requirements. F4 is the 1/2 Amp power supply fuse for the auxiliary 120VAC output

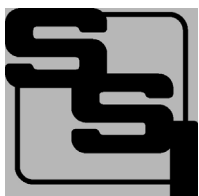

SOLID STATE INSTRUMENTS

a division of Brayden Automation Corp.
6230 Aviation Circle, Loveland, Colorado 80538
Phone: (970)461-9600 Fax: (970)461-9605
E-mail: support@solidstateinstruments.com

AUXILLARY POWER OUTPUT - UTILITY COMPARTMENT - The CIR-22A contains a 120VAC Auxillary Power Output, located in the utility compartment, for use by other utility-owned and installed equipment, such as load management receivers and switches. Fuse F4 protects this Auxillary Power Output and is normally provided with a 1/2 Amp fuse, but may be increased up to 2 Amps maximum. **This output may only be used if the CIR-22A is powered by a 120VAC source.**

AUXILLARY POWER OUTPUT - CUSTOMER COMPARTMENT - Not implemented on the CIR-22A.

***** WARNING *****

USE CAUTION WHEN INSTALLING OR REMOVING THE UTILITY COMPARTMENT COVER TO INSURE THAT THE COVER DOES NOT COME INTO CONTACT WITH FUSES F4, F6 OR F7.