

# INSTRUCTION SHEET

## PIR-2C PULSE ISOLATION RELAY

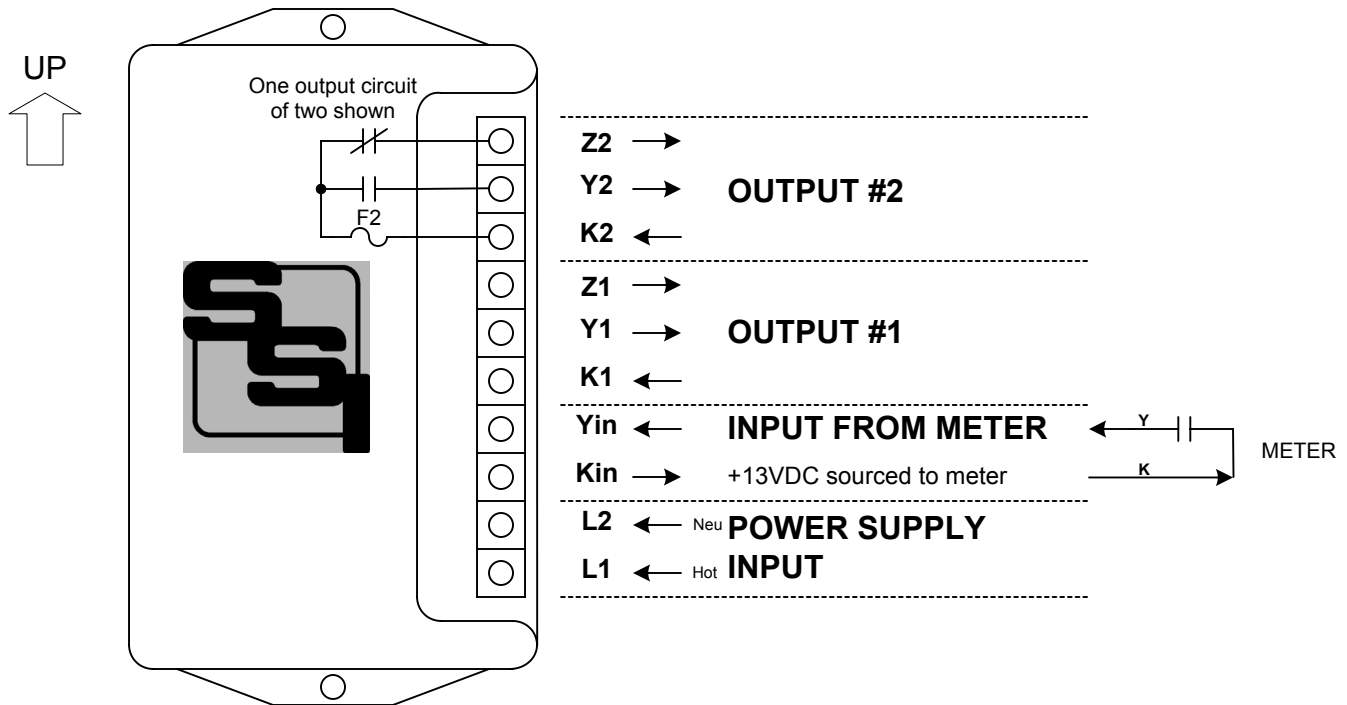

**MOUNTING POSITION** - Because the PIR-2C contains mercury-wetted relays, it must be mounted in a vertical position to operate correctly.

**POWER INPUT** - The PIR-2C should be powered by an AC voltage of between 90 and 300 volts. The hot lead should be connected to the L1 terminal and the neutral to the L2 terminal.

**METER CONNECTIONS** - The PIR-2C's "Kin" and "Yin" input terminals should be connected to the meter's "K" & "Y" terminals: "Kin" to "K" and "Yin" to "Y". The PIR-2C's "K" terminal provides the +13VDC wetting voltage to the meter's "K" terminal or other contacts.

**FUSES** - The fuses are 3AG or AGC type and may be up to 2 Amps in size. 1/2 Amp fuses are supplied standard with the unit unless otherwise specified.

**OUTPUTS** - Relay contacts are isolated Form "C" dry-contact outputs. The device which will receive the pulses from the PIR-2C must also supply a "sense" or "wetting" voltage to the "K" terminal of each output. In the center of the board just above the transformer is a 3-pin header (SW3) which selects either long and short output pulses. Read the reverse side of this sheet before setting the jumper. Arc suppression for the contacts of the mercury-wetted relays is provided internally.



## SOLID STATE INSTRUMENTS

a division of Brayden Automation Corp.  
6230 Aviation Circle, Loveland Colorado 80538  
Phone: (970)461-9600 Fax: (970)461-9605  
E-mail: support@solidstateinstruments.com

# WORKING WITH THE PIR-2C RELAY

**BLOCKING NOISE:** The PIR-2C has a built-in circuit which is designed to reject noise while allowing the detection of valid pulses from a sending source. The circuit accomplishes this

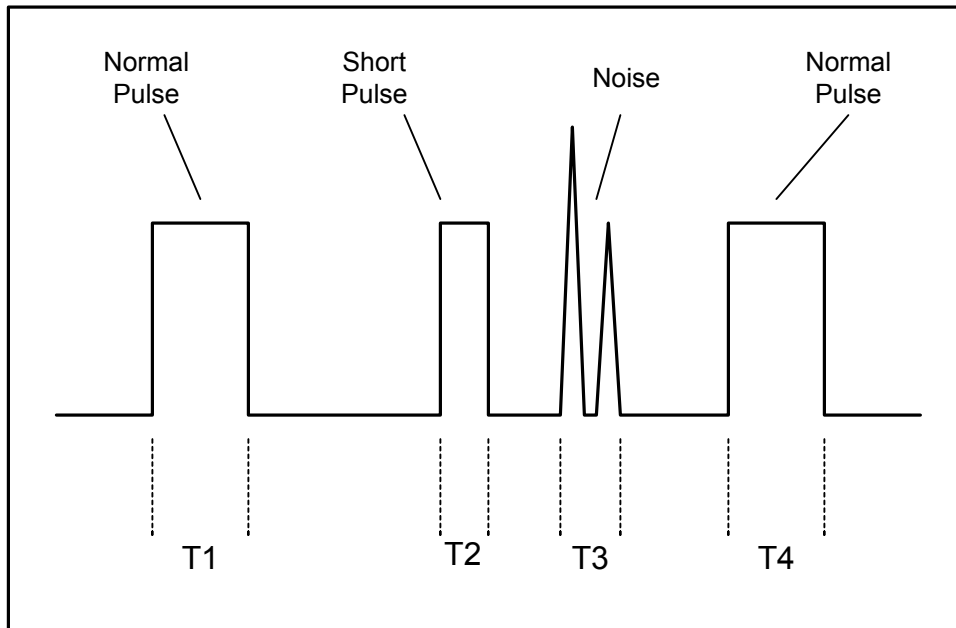

by measuring the time the input voltage is present. If the input voltage is present for less than 20 to 25 milliseconds, it is assumed to be noise. An input of longer duration is classified as a valid input and an output will occur. In the illustration to the left, the normal pulses with time durations of T1 and T4 will cause an output. The short pulse of time duration

T2 and the noise with duration T3 will be rejected because the time (pulse width) is not enough, even though the voltage is of sufficient magnitude. The time T4 could be many or thousands of times as long as T1 and it would still be a valid time pulse since it has met the minimum time requirement of 20 to 25 milliseconds. The time duration of 20 to 25 milliseconds has been chosen as the factory-set value since one cycle of the 60 hertz AC line frequency represents 16.67 milliseconds. Most induced noise and arcing discharges do not last longer than this, while most contact closures are a great deal longer. The time duration of the noise rejection circuit may be modified by changing either a resistor and/or a capacitor. In a very dirty (noise-wise) environment, it might be desirable to set the delay up to as much as 250 milliseconds. If you need a longer input validation period, check with the factory for correct values and procedures.

**OUTPUT PULSE DURATION:** The PIR-2C can output two types of pulses - long or short - depending upon the position of the small jumper selection switch located in the middle of the board just above the transformer and to the left of the "Kin" terminal. In the "S" (right) position, the PIR-2C outputs a fixed length "short" pulse of about 100 milliseconds in duration occurring 20 to 25 milliseconds after the input of the leading edge of a valid input pulse. The length of the output pulse may be modified by changing the value of a resistor and/or a capacitor to allow much longer or shorter output periods. If the switch is in the "S" position and the incoming pulse is of sufficient time duration to be a valid pulse, but is less than 100 milliseconds, the output time period will still be 100 milliseconds. Thus, the PIR-2C can be used as a pulse stretcher. In the "L" (left) position, the PIR-2C outputs a "long" pulse which is the same duration as the length of a valid input pulse plus 100 milliseconds, occurring 20-25 milliseconds after the input of the leading edge of a valid input pulse. Call the factory if you have questions or need additional information.