

2025



**SOLID STATE
INSTRUMENTS**

A Product Family Owned by Radian Research



TO OUR VALUED CUSTOMERS:

Welcome to our 2025 Edition of the Solid State Instruments Catalog! We sincerely appreciate your interest in our products and hope that you find exactly the pulse metering product you are looking for. As we start our 45th year, please know that my team members and I are dedicated to our customers and are committed to making the most reliable, highest quality products in the industry, all while providing first-class customer service.

This year we've continued to strengthen the green initiatives of Solid State Instruments. In 2008, we converted to a mercury-free product line, when we transitioned to our new Solid State Elite product line. A quick product reference guide found on our website will help you cross the legacy SSI products with the newest version.

In following with the tradition of our previous catalogs, we've continued to put our contact information on the bottom of every product page. We've done this to make it easy for you to contact us and get the products and technical support you need! We invite you to visit our website at www.solidstateinstruments.com for the latest product additions and information.

Once again this note would not be complete without giving you my sincere thanks for your business. It is your continued patronage that has made Solid State Instruments into the company that it is today, and it is our goal to uphold the reputation that you have helped us build. We will work diligently to meet your requests and needs in the best manner possible. To our future customers, we are privileged to have caught your interest and we look forward to serving you.

Best regards,

President & CEO

A Product Family Owned by Radian Research
SOLID STATE INSTRUMENTS
sales@radianresearch.com



A Product Family Owned by Radian Research
3852 Fortune Drive, Lafayette, IN 47905 USA
Ph: (765) 449-5500 • Fax: (765) 448-4614
www.radianresearch.com

TABLE OF CONTENTS

Selecting the Correct Relay	2
Terms & Definitions	3
SSI Standard	
MODULAR RELAYS	
PIR-24	4
SPR-1	6
SPR-2	8
SPR-3	10
SPR-22	12
SPR-24	14
SPR-36B	16
SPR-44B	18
SPR-48	20
SPR-110	22
SPR-112	24
SPR-510	26
SPR-610	28
RTR-22+	30
RTR-2C	32
RTR-2SP	34
DPR-1	36
DPR-2	38
DPR-4	40
SELF-CONTAINED RELAYS (OUTDOOR)	
SPR-3E	42
SPR-24E	44
SSI Elite	
MODULAR RELAYS	
RPR-1PS	46
RPR-2PS	48
RPR-3PS	50
RPR-22PS	52
RPR-24PS	54
RPR-33PS	56
RPR-903PS	58
PIR-1PS+	60
PIR-2PS+	62
PIR-3PS+	64
PCR-3PS	66
SELF-CONTAINED RELAYS (OUTDOOR)	
CIR-1PS+	68
CIR-2PS+	70
CIR-3PS+	72
CIR-13PS	74
CIR-22PS	76
CIR-24PS	78
CIR-24NG	80
CIR-44	82

Totalizers

MPT-2C	84
MPT-4C	86
MPT-8C	88
MPT-10C	90
MPT-440	92
NPR-1	94
NPR-8	96

Pulse Links

PRL-2SC	99
PRL-1600C	100
OPL-1B	102
OPL-1C	104
OPL-4B	106
OPL-4C	108
OPL-8B	110
OPL-8C	112
PTR-1PS	114
PTR-2PS	116
CLR Series	118

Specialty Devices

PPG-1	120
WPG-1	122
WPG-1E	124
WPG-1SC	126
MPG-3	128
MPG-3E	130
MPG-3ES	132
MPG-3SC	134
MPG-3SC-R22	136
CLS-1	138
PMC-1	140
EXP Expansion Boards	142
CID-1	144
CID-2	146
CID-3	148
CID-4	150
MPS-2	152
P-1	154
PPC-1B	156
PPC-2	158
PPT-1	160
OPP-1	162
OPP-1i	164
CLC-1	166
PCL-2	168
DCS-1	170
DCS-2	171

Solar Power Supplies

SPS-2	172
SPS-5	174
SPS-6	176
SPS-7	178
SPS-9	180
Typical Hookups	182
Case Schematics	187
Warranty-Shipping Terms	188

SELECTING THE CORRECT RELAY

Do you want a Fully Self-Contained Relay, a Modular Relay, or a Totalizing Relay?

Self-Contained Relays are an all-in-one solution including a weather-resistant enclosure for outdoor mounting. They contain separate utility and customer compartments.

Modular Relays are housed in a polycarbonate case and are suitable for mounting indoors or in another enclosure as part of a metering system. Totalizing relays are special purpose devices packaged in the same polycarbonate case as the modular relays.

What Input Format does your pulse sending device have — 2-Wire, 3-Wire or Field-Selectable?

Input format refers to the number of wires between the sending unit (usually an electric meter) and the pulse isolation relay. For an energy signal, it can be either a 2-wire or a 3-wire system. For a time or end-of-interval signal, it is usually a 2-wire system. Many newer electronic metering devices, however, are using a 2-wire format for both. A field-selectable device has a 2 or 3-wire input and allows the installer to select the configuration upon installation.

What Output Format is required?

The output format is either a 3-Wire, 2-Wire, field-selectable or specialty type. The 3-wire output is a Form C configuration and consists of K, Y and Z terminals. The 2-wire output is a Form A configuration and consists of K and Y terminals. The field selectable type allows the installer to select a 2-wire or 3-wire output upon installation of the relay. Specialty types perform special functions like pulse dividing, scaling or conversion.

How many Isolated Outputs are required on a relay?

The number of output relays on an SSI isolation relay is generally identified by the last numerical digit(s) of the relay's model number. For example, an RPR-2P has two relay outputs. Relays are available with up to 12 outputs.

ADDITIONAL CONSIDERATIONS:

What is the Minimum Time the sending device's contact is made up?

The sending device must have contacts made up (closed) for at least 25 milliseconds for the relay to reliably switch. All SSI relays will work properly if the sending device's contacts are made up for a minimum of 25 milliseconds.

What is the Minimum Current the sending device must switch to reliably operate the relay?

Most relays listed in this catalog require the sending device contacts to switch currents less than 20 milliamps to operate the relay reliably.

What is the Maximum Output Current the relay can switch?

The maximum current-carrying capacity of all SSI Elite relay outputs is 3/4 amp, with total power dissipation of 50 VA. SSI Elite relays are equipped at the factory with 1/2 amp fuses. Equip the relay for your application with the correct size fuse up to 1/2 amp.

SSI Standard relays have a maximum current carrying capacity of 100 mA, with total power dissipation of 800 mW. SSI Standard relays are equipped with 1/10th amp fuses.



A Product Family Owned by **RADIAN RESEARCH**
3852 Fortune Dr. • Lafayette, IN 47905
Ph: (765) 449-5500 Fax: (765) 448-4614

www.solidstateinstruments.com • www.radianresearch.com

TERMS & DEFINITIONS

2-WIRE	A transmission system that uses 2 wires and usually transmits positive-going pulses of some duration with a rest (or zero voltage level) between pulses. Historically, this type of pulse system lacked immunity to induced noise. Often referred to as Form A.
3-WIRE	A transmission system that employs 3 wires and has a signal on the common to one of the two contacts at all times, but never simultaneously to both. This type of system is much less prone to noise than a 2-wire system because a signal is always present. Often referred to as Form C.
"DRY" CONTACTS	A relay's contacts that have no electricity applied to them from the device in which they are incorporated. A voltage is supplied by an external device or system.
FORM "A" CONTACTS	An industry standard SPST contact arrangement that is normally-open or the non-made up position, usually referred to as K & Y. Also called 2-wire.
FORM "C" CONTACTS	A set of SPDT contacts consisting of one Form "A" and one Form "B" with a single "common" ("K") contact. A Form "C" set of contacts will break one set of contacts before making up the opposite set. Generally referred to as K, Y & Z.
"K" LEAD	The center or common lead of a 3-Wire (Form C) or single-pole double-throw switch.
LATCHING RELAY	A relay that will stay in the last position it was in when voltage was removed.
MERCURY WETTED CONTACTS	Contacts that have a very small amount of mercury around the contact point to prevent arcing or "bounce" when the contacts close. Most mercury-wetted relays (switches) must be mounted in the vertical position.
MILLISECOND	One one-thousandth of a second.
POWER SOURCE VOLTAGE	The voltage provided to power the operating equipment. Usually 120 VAC or 277 VAC, but also be station battery voltages of 24, 48 or 125 VDC.
REED SWITCH	A switch that is enclosed in a small glass tube, that is controlled by a magnet(s) or magnetic field acting on it.
SENSE VOLTAGE	The voltage used to detect the operation of either contact opening or closing as with watt-hour meters and energy controllers. Industry convention requires that the receiving device supply the sense voltage to the sending device (i.e. relay to meter, energy control system to relay). Also called "wetting voltage."
SOLID STATE CONTACTS	Contacts that switch power that have no moving parts. Contacts are made of a silicon material.
SOLID STATE RELAY	A relay using solid state contacts that switch power that have no moving parts. Contacts are made of a silicon material. Generally solid state relays are non-latching and have lower power handling capabilities than mercury-wetted relays.
"Y" & "Z" LEADS	The normally-open and normally-closed contacts, respectively, of a Form C or single-pole, double-throw (SPDT) switch.
"T1" & "T2" LEADS	The time control (end-of-interval) leads coming off of most meters. Normally a Form A contact closure to a two-wire transmission system.



SSI STANDARD

PIR-24 DUAL CHANNEL PULSE ISOLATION RELAY

DESCRIPTION

The PIR-24 dual pulse isolation relay is designed to provide four isolated dry-contact, solid state Form A (KY) outputs from two Form A (KY) inputs. The primary application for the PIR-24 is when two independent isolation relay channels are desired, each with two identical and isolated outputs yet bundled in one compact package.



The PIR-24 operates over the standard SSI wide voltage range utilizing the auto-ranging power supply from 90 to 300VAC. The PIR-24 has a built-in off-line switching power supply generating a +13VDC sense voltage. The sense voltage is sent to each electric meter's Y pulse initiator output terminal from the PIR-24's "Y1in" and "Y2in" input terminals, returning to the "K1in" and "K2in" terminals, the common return for both meters. Each output relay follows one of the two inputs, thus allowing each input to control two relays. Output relays 1 and 2 follow input 1, while outputs 3 and 4 follow input 2.

The PIR-24 may be used with electric meters having electro-mechanical or semiconductor output contacts, either high or low voltage. Typical applications include interfaces between utility metering devices and customer-owned energy control systems, demand recorder applications, and supervisory control systems (SCADA) interfaces. The PIR-24 relay is designed for high-speed pulses and can switch up to 36,000 pulses/hour. The outputs are non-latching.

Bright RED LED indicators, one on each input, display each channel's relay status at all times thus allowing a rapid check of the system's performance without requiring any additional test equipment. The PIR-24's input and output terminal strip is a "EURO" type connector. When the stripped wire has been correctly installed in the terminals "slot" no conductive parts are exposed on the surface of the terminal strip, thus allowing the user maximum protection from accidental electrical shock. Each "K" lead of the PIR-24's four outputs is fused to prevent damage to the relays under almost any condition a user might cause such as excessive current, incorrect wiring, etc.

The PIR-24 has built-in MOV transient protection for the solid-state relay contacts which eliminates the need for external or off-the-board transient suppressors. All component parts which have power applied to them, with the exception of the input/output terminal strip are enclosed in a polycarbonate cover for maximum protection.

The mounting base plate is also made of polycarbonate and offers excellent electrical insulation between the circuits and the mounting surface.

FUNCTIONAL SUMMARY

	IN	OUT
#	2	4
TYPE	2 Wire	2 Wire
FORM	A	A

PIR-24



SSI ELITE

PIR-24 DUAL CHANNEL PULSE ISOLATION RELAY

SPECIFICATIONS

ELECTRICAL

Power Input:	90 to 300 VAC. Burden: 10 mA at 120 VAC
Signal Input:	Two Form A inputs. "Kin" is common return. Each input has a "Yin" input terminals for pulse signal from meter.
Outputs:	Four sets of dry Form A contacts (K, & Y) for energy pulses. The contacts are rated at 125VAC/VDC at 100milliamps. The maximum rating of the contacts is 800mW. Each output is factory fused at 1/10 amp. (3AG)
Contact On-State Resistance:	25 ohms maximum, 18 typical
Operate and Release Time:	Turn On Time - .5 mS typical; 3 mS MAX Turn Off Time - .1 mS typical; 1 mS MAX
Input/Output Isolation Voltage:	2500Vrms

MECHANICAL

Mounting:	Any position
Size:	3.27" wide, 5.70" high, 1.50" deep
Weight:	17 ounces

TEMPERATURE

Temperature Range:	-38° C to +70° C, -38.4° F to +158° F
Humidity:	0 to 98% non-condensing

AVAILABLE OPTIONS

Input Voltages:	125 VDC input using the DCS-3 Power Supply. Contact factory for other input voltages.
-----------------	---

PIR-24



SSI STANDARD

SPR-1 PULSE ISOLATION RELAY

DESCRIPTION

The SPR-1 pulse isolation relay is designed to provide one set of isolated (dry) solid state Form C (K, Y & Z) contacts from a single field-selectable Form A or C input over a wide voltage range. The outputs may be configured as either toggle or fixed mode. In toggle mode, the outputs are fixed at 100mS, regardless of the closure time of the input. The sense voltage provided by the SPR-1 to the sending device (typically a meter) is +13 VDC. The SPR-1 may be used with meters having high or low voltage semiconductor outputs, or mechanical output contacts (relays).



FUNCTIONAL SUMMARY

	IN	OUT
#	1	1
TYPE	2 Wire or 3 Wire	3 Wire
FORM	A or C	C

Applications include interfaces between utility metering devices and customer-owned energy control systems, demand recorders or supervisory control (SCADA) systems. The SPR-1 relay has a switch-selectable Form A or Form C input and input filtering circuitry to prevent noise from triggering the output. Pulses less than 18 mS are considered to be noise and will not be detected as a valid pulse. Once an input pulse greater in length than 18 mS is detected, the output will be changed to the state of the input.

Bright red and green LED indicators display the system's status at all times, thus allowing a rapid check of the system's performance without requiring any additional test equipment. The SPR-1's input and output terminal strip is a "Euro" type. When the stripped wire has been correctly installed in the terminal's slot, no conductive parts are exposed on the surface of the terminal strip, thus allowing the user maximum protection from accidental electrical shock. The "K" lead of the SPR-1's output is fused to prevent damage to the relays under almost any condition a user might cause such as excessive current, incorrect wiring, etc.

The SPR-1 has built-in MOV transient protection for the solid state relay contacts that eliminates the need for external protection. All component parts which have power applied to them, with the exception of the input/output terminal strip, are enclosed in a polycarbonate cover for maximum protection. The mounting base plate is also made of polycarbonate and offers excellent electrical insulation between the circuit and the mounting surface. The SPR-1 is normally mounted inside another enclosure, suitable for the user's intended application.

SPR-1



SSI ELITE

SPR-1 PULSE ISOLATION RELAY

SPECIFICATIONS

ELECTRICAL

Power Input:	120, 208-277. Burden: 10 mA at 120 VAC
Pulse Input:	One switch-selectable Form A or Form C input. "Kin" is common return. Input has "Yin" and "Zin" input terminals "pulled up" to +13VDC for pulse signal from meter. "Yin" terminal used for 2-Wire mode. Both used for 3-Wire.
Pulse Output:	One set of dry Form C contacts (K, Y, & Z) for energy pulses. The contacts are solid state rated at 125VAC/VDC at 100milliamps. The maximum power rating of the contacts is 800mW. Each output is factory fused at 1/10 amp. (3AG)
Contact On-State Resistance:	25 ohms maximum, 18 typical
Insulation Resistance:	50 megohms typical
Operate and Release Time:	2 to 3 milliseconds typical
Input/Output Isolation Voltage:	2500Vrms

MECHANICAL

Mounting:	Any position
Size:	3.27" wide, 5.70" high, 1.50" deep
Weight:	6 ounces

TEMPERATURE

Temperature Range:	-38° C to +70° C, -36.4° F to +158° F
Humidity:	0 to 98% non-condensing

AVAILABLE OPTIONS

Input Voltages:	125 VDC input using the DCS-1 Power Supply. Contact factory for other input voltages.
-----------------	---

SPR-1
SSi



SSI STANDARD

SPR-2 PULSE ISOLATION RELAY

DESCRIPTION

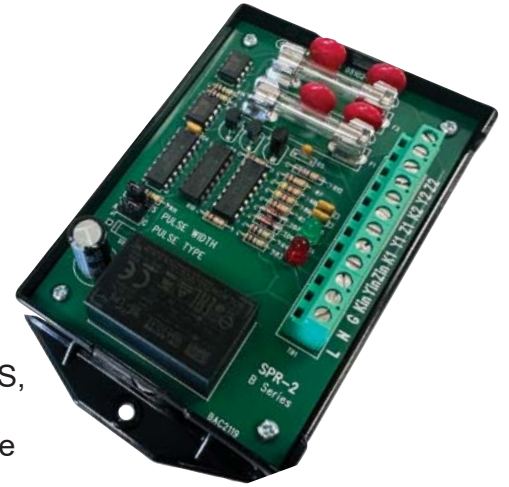

FUNCTIONAL SUMMARY

	IN	OUT
#	1	2
TYPE	2 Wire or 3 Wire	3 Wire
FORM	A or C	C

The SPR-2 pulse isolation relay is designed to provide two sets of isolated (dry) solid state Form C (K, Y & Z) contacts from a single field-selectable Form A or C input, over a wide voltage range. The outputs may be configured as either toggle or fixed mode. In toggle mode, the outputs are fixed at 100mS, regardless of the closure time of the input. The sense voltage between the SPR-2 and the sending device (typically a meter) is +13 VDC. The SPR-2 may be used with meters having high or low voltage semiconductor outputs, or mechanical output contacts (relays).

Applications include interfaces between utility metering devices and customer-owned energy control systems, demand recorders or supervisory control (SCADA) systems. The SPR-2 relay has a switch-selectable Form A or Form C input and input filtering circuitry to prevent noise from triggering the output. Pulses less than 18 mS are considered to be noise and will not be detected as a valid pulse. Once an input pulse greater in length than 18 mS is detected, the outputs will be changed to the state of the input.

Bright red and green LED indicators display the system's status at all times, thus allowing a rapid check of the system's performance without requiring any additional test equipment. The SPR-2's input and output terminal strip is a "Euro" type connector. When the stripped wire has been correctly installed in the terminal's slot, no conductive parts are exposed on the surface of the terminal strip, thus allowing the user maximum protection from accidental electrical shock. Each "K" lead of the SPR-2's outputs is fused to prevent damage to the relays under almost any condition a user might cause such as excessive current, incorrect wiring, etc.

The SPR-2 has built-in MOV transient protection for the solid state relay contacts that eliminates the need for external protection. All component parts which have power applied to them, with the exception of the input/output terminal strip are enclosed in a polycarbonate cover for maximum protection. The mounting base plate is also made of polycarbonate and offers excellent electrical insulation between the circuit and the mounting surface. The SPR-2 is normally mounted inside another enclosure, suitable for the user's intended application.

SPR-2



SSI STANDARD

SPR-2 PULSE ISOLATION RELAY

SPECIFICATIONS

ELECTRICAL

Power Input:	120, 208-277. Burden: 10 mA at 120 VAC
Pulse Input:	One switch-selectable Form A or Form C input. "Kin" is common return. Input has "Yin" and "Zin" input terminals "pulled up" to +13VDC for pulse signal from meter. "Yin" terminal used for 2-Wire mode. Both used for 3-Wire.
Pulse Output:	Two sets of dry Form C contacts (K, Y, & Z) for energy pulses. The contacts are solid state rated at 125VAC/VDC at 100milliamps. The maximum power rating of each contact is 800mW. Each output is factory fused at 1/10 amp. (3AG)
Contact On-State Resistance:	25 ohms maximum, 18 typical
Insulation Resistance:	50 megohms typical
Operate and Release Time:	2 to 3 milliseconds typical
Input/Output Isolation Voltage:	2500Vrms

MECHANICAL

Mounting:	Any position
Size:	3.27" wide, 5.70" high, 1.50" deep
Weight:	6 ounces

TEMPERATURE

Temperature Range:	-38° C to +70° C, -36.4° F to +158° F
Humidity:	0 to 98% non-condensing

AVAILABLE OPTIONS

Input Voltages:	125 VDC input using the DCS-1 Power Supply. Contact factory for other input voltages.
-----------------	---

SPR-2



SSI STANDARD

SPR-3 PULSE ISOLATION RELAY

DESCRIPTION

The SPR-3 pulse isolation relay is designed to provide three sets of isolated dry, solid state Form C (K, Y, & Z) contacts from a single field selectable Form A or C input over a wide voltage range. The outputs may be configured as either toggle or fixed mode. In toggle mode, the outputs are fixed at 100mS, regardless of the closure time of the input. The sense voltage of +13VDC is available on the "Yin" and "Zin" inputs, and is "pulled up." "Kin" is the common return. The SPR-3 may be used with meters having mechanical output contacts (relays), or high or low voltage semiconductor outputs.



Typical applications include interfaces between utility metering devices and customer owned energy control systems, demand recorder applications, and supervisory control systems (SCADA) interfaces. The SPR-3 relay has a switch selectable Form A or Form C input and input filtering circuitry to prevent noise from triggering the output. Any pulses less than 18mS are considered to be noise and will not be detected as a valid pulse. Once an input pulse greater than 18mS is detected, the outputs will be changed according to the status of the input.

Bright red and green LED indicators display the system status at all times, thus allowing a rapid check of the system's performance without requiring any additional test equipment. The SPR-3's input and output terminal strip is a "Euro" type connector. When the stripped wire has been correctly installed in the terminals "slot", no conductive parts are exposed on the surface of the terminal strip, thus allowing the user maximum protection from accidental electrical shock. Each "K" lead of the SPR-3's outputs is fused to prevent damage to the relays under almost any condition users might cause such as excessive current, incorrect wiring, etc.

The SPR-3 has built-in MOV transient protection for the solid state (silicon) relays contacts which eliminates the need for external protection. All component parts which have power applied to them, with the exception of the input/output terminal strip are enclosed in a polycarbonate cover for maximum protection. The mounting base plate is also made of polycarbonate and offers excellent electrical insulation between the circuit and the mounting surface.

FUNCTIONAL SUMMARY

	IN	OUT
#	1	3
TYPE	2 or 3 Wire	3 Wire
FORM	A or C	C

SPR-3



SSI STANDARD

SPR-3 PULSE ISOLATION RELAY

SPECIFICATIONS

ELECTRICAL

Pulse Input:	120, 208-277. Burden: 10 mA at 120 VAC
Signal Input:	One switch-selectable Form A or Form C input. "Kin" is common return. Input has "Yin" and "Zin" input terminals "pulled up" to +13VDC for pulse signal from meter. "Yin" terminal used for 2-Wire mode. Both used for 3-Wire.
Power Output:	Three sets of dry Form C contacts (K, Y, & Z) for energy pulses. The contacts are solid state rated at 125VAC/VDC at 100milli-amps. The maximum rating of the contacts is 800mW. Each output is factory fused at 1/10 amp. (3AG)
Contact On-State Resistance:	25 ohms maximum, 18 typical
Insulation Resistance:	50 megohms typical
Operate and Release Time:	2 to 3 milliseconds typical
Input/Output Isolation Voltage:	2500Vrms

MECHANICAL

Mounting:	Any position
Size:	3.50" wide, 7.20" high, 1.50" deep
Weight:	17 ounces

TEMPERATURE

Temperature Range:	-38° C to +70° C, -36.4° F to +158° F
Humidity:	0 to 98% non-condensing

AVAILABLE OPTIONS

Input Voltages:	125 VDC input using the DCS-1 Power Supply. Contact factory for other input voltages.
-----------------	---

SPR-3



SSI STANDARD

SPR-22 PULSE ISOLATION RELAY

DESCRIPTION

The SPR-22 pulse isolation relay provides two channels each with an isolated dry-contact, solid state Form C (K, Y, & Z) output from a Form A or C inputs. The SPR-22 has the functionality of the RPR-22PS but utilizes the standard solid state relays packaged in the small SSI footprint enclosure. The primary application for the SPR-22 is “Watts and Vars” or anywhere where two independent isolation relay channels are desired in one package.



FUNCTIONAL SUMMARY

	IN	OUT
#	2	2
TYPE	2 or 3 Wire	3 Wire
FORM	A or C	C

SPR-22

The SPR-22 operates over the standard SSI wide voltage range. The SPR-22 has a built-in low voltage transformer-isolated power supply generating a +13VDC sense voltage. The sense voltage is sent to each electric meter’s Y and Z pulse initiator output terminals from the SPR-22’s “Y1in”/”Z1in” and “Y2in”/”Z2in” input terminals, returning to the “K1in” and “K2in” terminals, the common return for both meters.

The SPR-22 may be used with electric meters having electro-mechanical or semiconductor output contacts, either high or low voltage. Typical applications include interfaces between utility metering devices and customer-owned energy control systems, demand recorders, and supervisory control systems (SCADA) interfaces. The SPR-22 relay is designed for high-speed pulses and can switch up to 72,000 pulses/hour in 3-Wire mode, and 36,000 pulses/hour in 2-Wire mode. The outputs are non-latching. Each input may be configured for either a “long” or “short” output pulse. In the “long” output mode, the output pulse width exactly follows (or “mirrors”) the input pulse width. In the “short” output mode, the output pulse is fixed at 100 milliseconds (mS). The “short” mode is normally used for end-of-interval pulses or where a fixed pulse width is needed.

Bright red and green LED indicators, one on each input, display each channel’s relay status at all times thus allowing a rapid check of the system’s performance without requiring any additional test equipment. The SPR-22’s input and output terminal strip is a “EURO” type connector. When the stripped wire has been correctly installed in the terminals “slot” no conductive parts are exposed on the surface of the terminal strip, thus allowing the user maximum protection from accidental electrical shock. Each “K” lead of the SPR-22’s outputs is fused to prevent damage to the relays under almost any condition a user might cause such as excessive current, incorrect wiring, etc.

The SPR-22 has built-in MOV transient protection for the solid-state relay contacts which eliminates the need for external or off-the-board transient suppressors. All component parts which have power applied to them, with the exception of the input/output terminal strip are enclosed in a polycarbonate cover for maximum protection.

The mounting base plate is also made of polycarbonate and offers excellent electrical insulation between the circuits and the mounting surface.



SSI STANDARD

SPR-22 PULSE ISOLATION RELAY

SPECIFICATIONS

ELECTRICAL

Power Input:	90 to 300 VAC. Burden: 10 mA at 120 VAC
Pulse Input:	Two switch-selectable Form A or Form C inputs. "Kin" is common return. Each input has "Yin" and "Zin" input terminals for pulse signal from meter. "Yin" terminal used for 2-Wire mode. Both used for 3-Wire.
Pulse Output:	Two sets of dry Form C contacts (K, Y, & Z) for energy pulses. The contacts are rated at 125VAC/VDC at 100milliamps. The maximum rating of the contacts is 800mW. Each output is factory fused at 1/10 amp. (3AG)
Contact On-State Resistance:	25 ohms maximum, 18 typical
Operate and Release Time:	Turn On Time - .5 mS typical; 3 mS MAX Turn Off Time - .1 mS typical; 1 mS MAX
Input/Output Isolation Voltage:	2500Vrms

MECHANICAL

Mounting:	Any position
Size:	3.27" wide, 5.70" high, 1.50" deep
Weight:	6 ounces

TEMPERATURE

Temperature Range:	-38° C to +70° C, -36.4° F to +158° F
Humidity:	0 to 98% non-condensing

AVAILABLE OPTIONS

Input Voltages:	125 VDC input using the DCS-1 Power Supply. Contact factory for other input voltages.
-----------------	---

SPR-22



SSI STANDARD

SPR-24 DUAL PULSE ISOLATION RELAY

DESCRIPTION

The SPR-24 dual pulse isolation relay is designed to provide four isolated dry-contact, solid state Form C (K, Y, & Z) outputs from two Form A or C inputs. The primary application for the SPR-24 is where two independent isolation relay channels are desired with multiple outputs on each channel, in one package.

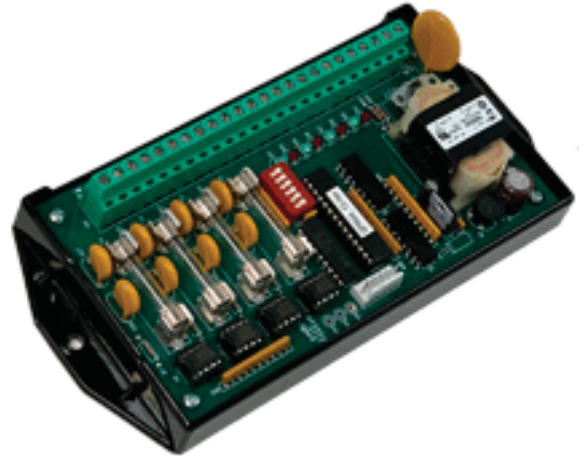

FUNCTIONAL SUMMARY

	IN	OUT
#	2	4
TYPE	2 Wire or 3 Wire	3 Wire
FORM	A or C	C

The SPR-24 operates over the standard SSI wide voltage range. The SPR-24 has a built-in low voltage transformer-isolated power supply generating a +13VDC sense voltage. The sense voltage is sent to each electric meter's Y and Z pulse initiator output terminals from the SPR-24's "Y1in"/"Z1in" and "Y2in"/"Z2in" input terminals, returning to the "K1in" and "K2in" terminals, the common return for both meters. Output relays 1 and 2 follow input 1, while outputs 3 and 4 follow input 2.

The SPR-24 may be used with electric meters having electro-mechanical or semiconductor output contacts, either high or low voltage. Typical applications include interfaces between utility metering devices and customer-owned energy control systems, demand recorder applications, and supervisory control systems (SCADA) interfaces. The SPR-24 relay is designed for high speed pulses and can switch up to 72,000 pulses/hour in 3-Wire mode and 36,000 pulses/hour in 2-Wire mode. The outputs are non-latching. Each input may be configured for either a "long" or "short" output pulse. In the "long" output mode, the output pulse width exactly follows (or "mirrors") the input pulse width. In the "short" output mode, the output pulse is fixed at 100 milliseconds (mS). The "short" mode is normally used for end-of-interval pulses or where a fixed pulse width is needed.

Bright red and green LED indicators, one on each input, display each channel's relay status at all times thus allowing a rapid check of the system's performance without requiring any additional test equipment. The SPR-24's input and output terminal strip is a "Euro" type connector. When the stripped wire has been correctly installed in the terminals "slot" no conductive parts are exposed on the surface of the terminal strip, thus allowing the user maximum protection from accidental electrical shock. Each "K" lead of the SPR-24's four outputs is fused to prevent damage to the relays under almost any condition a user might cause such as excessive current, incorrect wiring, etc.

The SPR-24 has built-in MOV transient protection for the solid-state relay contacts which eliminates the need for external or off-the-board transient suppressors. All component parts which have power applied to them, with the exception of the input/output terminal strip are enclosed in a polycarbonate cover for maximum protection.

The mounting base plate is also made of polycarbonate and offers excellent electrical insulation between the circuits and the mounting surface.

SPR-24



SSI STANDARD

SPR-24 DUAL PULSE ISOLATION RELAY

SPECIFICATIONS

ELECTRICAL

Power Input:	120, 208-277. Burden: 10 mA at 120 VAC
Pulse Inputs:	Two switch-selectable Form A or Form C inputs. "Kin" is common return. Each input has "Yin" and "Zin" input terminals for pulse signal from meter. "Yin" terminal used for 2-Wire mode. Both used for 3-Wire.
Pulse Outputs:	Four sets of dry Form C contacts (K, Y, & Z) for energy pulses. The contacts are rated at 125VAC/VDC at 100milliamps. The maximum rating of the contacts is <u>800mW</u> . Each output is factory fused at 1/10 amp. (3AG)
Contact On-State Resistance:	25 ohms maximum, 18 typical
Operate and Release Time:	2 to 3 milliseconds typical
Input/Output Isolation Voltage:	2500Vrms

MECHANICAL

Mounting:	Any position
Size:	3.50" wide, 7.20" high, 1.50" deep
Weight:	17 ounces

TEMPERATURE

Temperature Range:	-38° C to +70° C, -36.4° F to +158° F
Humidity:	0 to 98% non-condensing

AVAILABLE OPTIONS

Input Voltages:	125 VDC input using the DSC-1 Power Supply. Contact factory for other input voltages.
-----------------	---

SPR-24



SSI STANDARD

SPR-36B TRIPLE PULSE ISOLATION RELAY

DESCRIPTION

The SPR-36B triple pulse isolation relay is designed to provide six isolated dry contact, solid state Form C (K, Y, & Z) outputs from three Form A or C inputs. The primary application for the SPR-36B is where three independent 2-output pulse isolation relays, OR two independent 3-output pulse isolation relays are desired in one ultra-compact package. Inputs may be paralleled for a variety of flexible applications.



FUNCTIONAL SUMMARY

	IN	OUT
#	3	6
TYPE	2 Wire or 3 Wire	3 Wire
FORM	A or C	C

SPR-36B

The SPR-36B operates over the standard SSI wide voltage range. The SPR-36B has a built-in low voltage transformer-isolated power supply generating a +13VDC sense voltage. The sense voltage is sent to each meter's Y and Z terminals from the SPR-36's Yin and Zin input terminals, returning to the Kin terminal, the common return for all meters. Since all meters supplying pulses to the SPR-36B have a common reference, a number of flexible input configurations can be wired.

The SPR-36B may be used with electric meters having electro-mechanical or semiconductor output contacts, either high or low voltage. The SPR-36B's inputs are configured to accept open-collector transistor or open-drain FET solid state pulse initiator switches. Typical applications include interfaces between utility metering devices and customer-owned energy control systems, demand recorder applications, and supervisory control systems (SCADA) interfaces. The SPR-36B relay is designed for high speed pulses and can switch up to 72,000 pulses/hour in 3-Wire mode and 36,000 pulses/hour in 2-Wire mode. The outputs are non-latching. The SPR-36B outputs' pulse timing follows the inputs' timing such that output pulses have the exact same pulse width as the input.

Bright red and green LED indicators, one of each on every input AND output, display each channel's relay status at all times, thus allowing a rapid check of the system's performance without requiring any additional test equipment. The SPR-36B's input and output terminal strip is a "Euro" type. When the stripped wire has been correctly installed in the terminals "slot", no conductive parts are exposed on the surface of the terminal strip, thus allowing the user maximum protection from accidental electrical shock. Each "K" lead of the SPR-36B's six outputs is fused to prevent damage to the relays under almost any condition a user might cause such as excessive current, incorrect wiring, etc. Fuses are standard-sized 3AG or AGC 1/10th Amp fuses.

The SPR-36B has built-in MOV transient protection for the solid state relay contacts which eliminates the need for external or off-board transient suppressors. All component parts which have power applied to them, with the exception of the input/output terminal strip are enclosed in a polycarbonate cover for maximum protection.

The mounting base plate is also made of polycarbonate and offers excellent electrical insulation between the circuits and the mounting surface.



SSI STANDARD

SPR-36B TRIPLE PULSE ISOLATION RELAY

SPECIFICATIONS

ELECTRICAL

Power Input:	120 to 277 VAC. Burden: 10 mA at 120 VAC
Pulse Input:	Three independent field-selectable, Form A or Form C inputs. Each input has “Yin” and “Zin” input terminals wetted, pulled up with +13VDC. “Kin” is common return“. Form A input uses the ‘Yin’ terminal and Form C uses the “Yin” and “Zin” terminals for the input from the meter.
Pulse Output:	Six (6) dry Form C contacts (K, Y, & Z) for energy pulses. The relay contacts are solid state with “no bounce” circuitry. Outputs are rated at 125VAC/VDC 1/10th Amp(100 milliamps). Factory fused at 1/10 amp @ 250VAC using standard AGC or 3AG fuses.
Contact On-State Resistance:	25 ohms maximum, 18 typical
Operate and Release Time:	2 to 3 milliseconds typical
Input/Output Isolation Voltage:	2500Vrms

MECHANICAL

Mounting:	Any position
Size:	3.50” wide, 7.20” high, 1.50” deep
Weight:	17 ounces

TEMPERATURE

Temperature Range:	-38° C to +70° C, -36.4° F to +158° F
Humidity:	0 to 98% non-condensing

AVAILABLE OPTIONS

Input Voltages:	125 VDC input using the DCS-1 Power Supply. Contact factory for other input voltages.
-----------------	---

SPR-36B



SSI STANDARD B-SERIES

SPR-44B QUAD PULSE ISOLATION RELAY

DESCRIPTION

The SPR-44B quad pulse isolation relay is designed to provide four isolated dry-contact, solid state Form C (K, Y, & Z) outputs from four Form A or C inputs. The primary application for the SPR-44 is where four independent isolation relay channels are desired in one package. A variety of pulse splitting relaying schemes can be accomplished by paralleling two or more inputs.

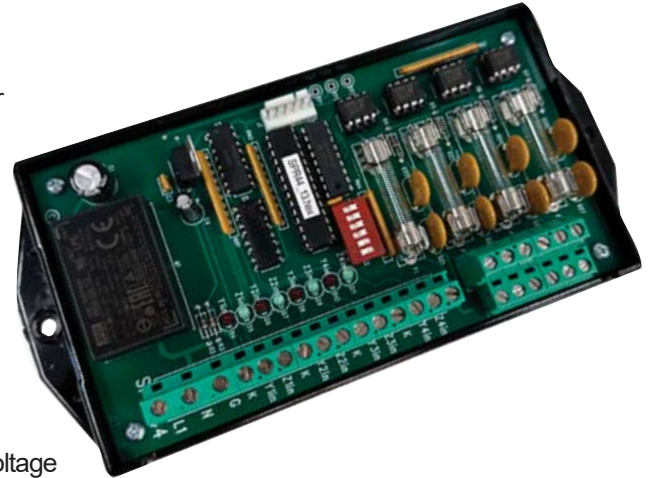

The SPR-44B operates over the standard SSI wide voltage range. The SPR-44B has a built-in low voltage transformer-isolated power supply generating a +13VDC wetting voltage

The sense voltage is sent to each meter's Y and Z terminals from the SPR-44B's "Yin" and "Zin" input terminals, returning to the "Kin" terminal, the common return for all meters. Since all meters supplying pulses to the SPR-44B have a common reference, a number of flexible input configurations can be wired. For example, two inputs can be wired in parallel giving a "splitting" configuration where one input and two outputs is desired.

The SPR-44B may be used with electric meters having electro-mechanical or semiconductor dry-contact output contacts, either high or low voltage. The SPR-44B's inputs are configured to also accept open-collector transistor or open-drain FET solid state pulse initiator switches. Typical applications include interfaces between utility metering devices and customer-owned energy control systems, demand recorder applications, and supervisory control systems (SCADA) interfaces. The SPR-44B relay is designed for high speed pulses and can switch up to 72,000 pulses/hour in 3-Wire mode and 36,000 pulses/hour in 2-Wire mode. The outputs are non-latching. The SPR-44B outputs' pulse timing follows the inputs' timing such that output pulses have the exact same pulse width as the input.

The SPR-44B also has a pulse conversion capability built in. Each of the four channels of the SPR-44B can be independently set for Normal or Conversion mode. In the pulse conversion mode, a 3-wire (FormC) input can be converted to a 2-Wire (FormA) pulse while maintaining the same pulse value. Additionally, a 2-wire (FormA) input can be converted to a 3-Wire (FormC) pulse while maintaining the same pulse value.

Bright red and green LED indicators, one of each on every input, indicates each channel's relay status at all times thus allowing a rapid check of the system's performance without requiring any additional test equipment. The SPR-44B's input and output terminal strip is a "EURO" type connector. When the stripped wire has been correctly installed in the terminals "slot" no conductive parts are exposed on the surface of the terminal strip, thus allowing the user maximum protection from accidental electrical shock. Each "K" lead of the SPR-44B's four outputs is fused to prevent damage to the relays under almost any condition a user might cause such as excessive current, incorrect wiring, etc.

The SPR-44B has built-in MOV transient protection for the solid state relay contacts which eliminates the need for external or off-board transient suppressors. All component parts which have power applied to them, with the exception of the input/output terminal strip are enclosed in a polycarbonate cover for maximum protection.

The mounting base plate is also made of polycarbonate and offers excellent electrical insulation between the circuits and the mounting surface.

FUNCTIONAL SUMMARY

	IN	OUT
#	4	4
TYPE	2 Wire or 3 Wire	3 Wire
FORM	A or C	C

SPR-44B



SSI STANDARD B-SERIES

SPR-44B QUAD PULSE ISOLATION RELAY

SPECIFICATIONS

ELECTRICAL

Power Input:	120 to 277 VAC. Burden: 10 mA at 120 VAC Four independent field-selectable, Form A or Form C inputs.
Pulse Input:	Each input has “Yin” and “Zin” terminals wetted “pulled up” with +13VDC. “Kin” terminal is the common return. The Form A input uses the “Yin” terminal, the Form C input uses the “Yin”, and “Zin” terminals for the input from the meter.
Pulse Output:	Four sets of dry Form C contacts (K, Y, & Z) for energy pulses. The relay contacts are solid state with “no bounce” circuitry. Outputs are rated at 125VAC/VDC 1/10th Amp(100 milliamps). Factory fused at 1/10 amp @ 250VAC. (3AG)
Contact On-State Resistance:	25 ohms maximum, 18 ohms typical
Insulation Resistance:	50 megohms typical
Operate and Release Time:	2 to 3 milliseconds typical
Input/Output Isolation Voltage:	3750Vrms

MECHANICAL

Mounting:	Any position
Size:	3.50” wide, 7.20” high, 1.50” deep
Weight:	12 ounces

TEMPERATURE

Temperature Range:	-38° C to +70° C, -36.4° F to +158° F
Humidity:	0 to 98% non-condensing

AVAILABLE OPTIONS

Input Voltages:	(-SP2 Option) 125 VDC input (-SP12 Option) 12VDC input (1SP13 Option) 15-48VDC input
-----------------	--

SPR-44B



SSI STANDARD B-SERIES

SPR-48 PULSE ISOLATION RELAY

DESCRIPTION

The SPR-48 is a 4-channel pulse isolation relay designed for high-density pulse applications where two RPR-24PS or SPR-24 relays would be required. Eight isolated solid-state Form A (K&Y) dry-contact outputs are provided, two each from four Form A inputs. The SPR-48 relay contains standard-duty solid state outputs. The wetting voltage provided by the SPR-48 to the sending devices (typically electric meters) is +13 VDC. The SPR-48 may be used with meters having semiconductor or electro-mechanical output contacts (relays).

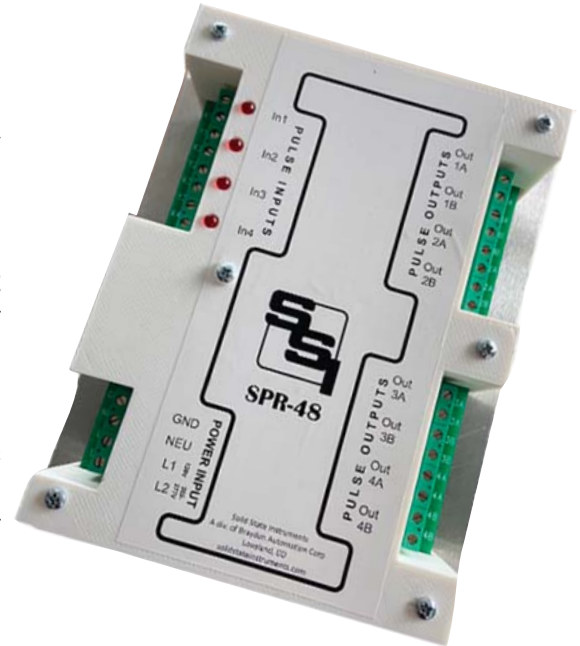

FUNCTIONAL SUMMARY

IN	OUT
4	8
2 Wire	2 Wire
A	A

TYPE
FORM

SPR-48

The SPR-48 relay's Form A inputs feature input filtering circuitry to prevent noise from false triggering the outputs. Bright red and green LED indicators display the system status at all times, thus allowing a rapid check of the system's performance without requiring any additional test equipment. The SPR-48's input and output terminal strips are "Euro" type. When the stripped wire has been correctly installed in the terminal's slot, no conductive parts are exposed on the surface of the terminal strip, thus allowing the user maximum protection from accidental electrical shock. The "K" lead of the SPR-48's outputs are fused to prevent damage to the relays under almost any condition a user might cause such as excessive current, incorrect wiring, etc.

The SPR-48 has built-in MOV transient protection for the solid state relay contacts that eliminates the need for external protection. The SPR-48 is provided on a chassis mount panel and normally mounted inside another enclosure, suitable for the user's intended application. An optional NEMA 4X enclosure is available with the SPR-48 mounted on an internal mounting plate.



SSI STANDARD B-SERIES

SPR-48 PULSE ISOLATION RELAY

SPECIFICATIONS

ELECTRICAL

Power Input:	120 to 277 VAC. Burden: 10 mA at 120 VAC
Pulse Input:	Four Form A inputs. "Kin" is common return. Input has "Yin" input terminals are "pulled up" to +13VDC for pulse signal from meter
Pulse Output:	Eight (8) Form A dry contacts (K & Y) for energy pulses. The contacts are solid state rated at 125VAC/VDC at 100milliamps. The maximum power rating of the contacts is 800mW. Each output is factory fused at 1/10 amp. (3AG)
Contact On-State Resistance:	25 ohms maximum, 18 ohms typical
Insulation Resistance:	50 megohms typical
Operate and Release Time:	2 to 3 milliseconds typical
Input/Output Isolation Voltage:	2500Vrms

MECHANICAL

Mounting:	Any position
Size:	7.00" wide, 9.00" high, 1.8" deep
Weight:	2 pounds

TEMPERATURE

Temperature Range:	-38° C to +70° C, -38.4° F to +158° F
Humidity:	0 to 98% non-condensing

AVAILABLE OPTIONS

Input Voltages:	<ul style="list-style-type: none">• 125 VDC input using DCS-1 Power Supply• +15-48VDC input using DCS-2 Power Supply• +12VDC & +24VDC/24VAC are also available. Contact Factory for other input voltages.
-----------------	---

All specifications are subject to change without notice.

SPR-48



SSI STANDARD

SPR-110 PULSE ISOLATION RELAY

DESCRIPTION

The SPR-110 pulse isolation relay is designed to provide ten sets of isolated dry, solid state Form C (K, Y, & Z) contacts from a single field selectable Form A or C input over a wide voltage range. The outputs may be configured as either toggle or fixed mode. In fixed mode, the outputs are fixed at 100mS, regardless of the closure time of the input. In toggle mode, the output time is the same as the input closure time. The sense voltage of +13VDC is available on the "Yin" and "Zin" inputs, and is "pulled up." "Kin" is the common return. The SPR-110 may be used with meters having electro-mechanical output contacts (relays), or high or low voltage semiconductor outputs.

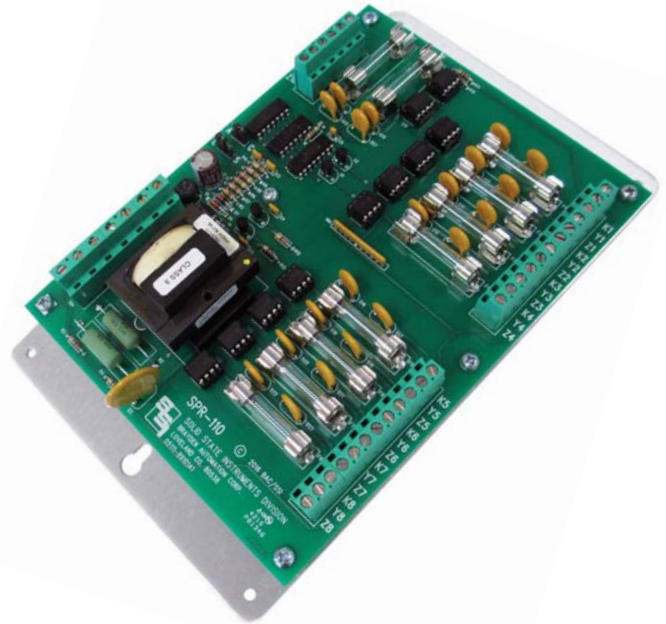

FUNCTIONAL SUMMARY

	IN	OUT
#	1	10
TYPE	2 Wire or 3 Wire	3 Wire
FORM	A or C	C

SPR-110

Typical applications include interfaces between utility metering devices and customer owned energy control systems, demand recorder applications, and supervisory control systems (SCADA) interfaces. The SPR-110 relay has a switch selectable Form A or Form C input and input filtering circuitry to prevent noise from triggering the output. Any pulses less than 18mS are considered to be noise and will not be detected as a valid pulse. Once an input pulse greater than 18mS is detected, the outputs will be changed according to the status of the input.

Bright red and green LED indicators display the system status at all times, thus allowing a rapid check of the system's performance without requiring any additional test equipment. The SPR-110's input and output terminal strip is a "Euro" type connector. When the stripped wire has been correctly installed in the terminals "slot", no conductive parts are exposed on the surface of the terminal strip, thus allowing the user maximum protection from accidental electrical shock. Each "K" lead of the SPR-110's outputs is fused to prevent damage to the relays under almost any condition users might cause such as excessive current, incorrect wiring, etc.

The SPR-110 has built-in MOV transient protection for the solid state (silicon) relays contacts which eliminates the need for external protection. The SPR-110 is provided on a mounting base plate between the circuit board and the mounting surface.



SSI STANDARD

SPR-110 PULSE ISOLATION RELAY

SPECIFICATIONS

ELECTRICAL

Pulse Input:	120, 208-277. Burden: 14 mA at 120 VAC
Signal Input:	One switch-selectable Form A or Form C input. "Kin" is common return. Input has "Yin" and "Zin" input terminals "pulled up" to +13VDC for pulse signal from meter. "Yin" terminal used for 2-Wire mode. Both used for 3-Wire.
Power Output:	Ten sets of dry Form C contacts (K, Y, & Z) for energy pulses. The contacts are solid state rated at 125VAC/VDC at 100milliamps. The maximum rating of the contacts is <u>800mW</u> . Each output is factory fused at 1/10 amp. (3AG)
Contact On-State Resistance:	25 ohms maximum, 18 typical
Insulation Resistance:	50 megohms typical
Operate and Release Time:	2 to 3 milliseconds typical
Input/Output Isolation Voltage:	2500Vrms

MECHANICAL

Mounting:	Any position
Size:	7" wide, 9" high, 1.8" deep
Weight:	2 pounds

TEMPERATURE

Temperature Range:	-38° C to +70° C, -38.4° F to +158° F
Humidity:	0 to 98% non-condensing

AVAILABLE OPTIONS

Input Voltages:	125 VDC input using the DCS-1C Power Supply. Contact factory for other input voltages.
-----------------	--

SPR-110



SSI STANDARD

SPR-112 PULSE ISOLATION RELAY

DESCRIPTION

The SPR-112 pulse isolation relay is designed to provide twelve sets of isolated solid state Form A (K & Y) dry-contact outputs from a single Form A pulse input over a wide voltage range. The SPR-112 relay contains standard duty solid state outputs. The sense voltage provided by the SPR-112 to the sending device (typically a meter) is +13 VDC. The SPR-112 may be used with meters having high or low voltage semiconductor outputs, or electro-mechanical output contacts (relays). The SPR-112 also doubles as a pulse generator and has two internal pulse sources: a 1 Hz Pulse generator and a variable pulse generator from .1 to 10 pulses per second.

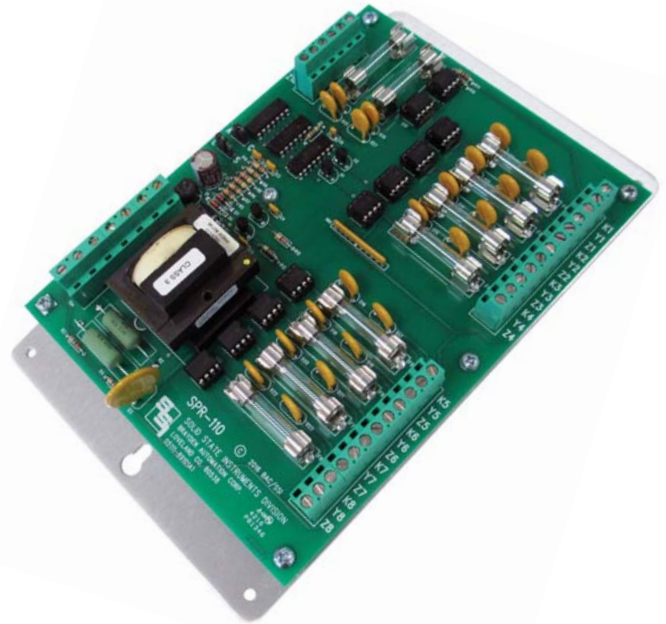

The SPR-112 relay has a switch-selectable input which can select the external Form A pulse input, the 1 Hz pulse generator or the internal variable pulse generator. Input filtering circuitry prevents noise from triggering the output. Pulses less than 18 mS are considered to be noise and will not be validated as a pulse. Once an input pulse greater in length than 18 mS is validated, the output will be changed to the state of the input.

Bright red and green pulse input LED indicators display the system's status at all times, thus allowing a rapid check of the system's performance without requiring any additional test equipment. The SPR-112's input and output terminal strips are "Euro" type. When the stripped wire has been correctly installed in the terminal's slot, no conductive parts are exposed on the surface of the terminal strip, thus allowing the user maximum protection from accidental electrical shock. The "K" lead of the SPR-112's output is fused to prevent damage to the relays under almost any condition a user might cause such as excessive current, incorrect wiring, etc.

The SPR-112 has built-in MOV transient protection for the solid state relay contacts that eliminates the need for external protection. The SPR-112 is mounted on an open chassis and is normally mounted inside another enclosure, suitable for the user's intended application and easy access for wiring.

FUNCTIONAL SUMMARY

IN	OUT
1	12
2 Wire	2 Wire
A	A

#

TYPE

FORM

SPR-112



SSI STANDARD

SPR-112 PULSE ISOLATION RELAY

SPECIFICATIONS

ELECTRICAL

Pulse Input:	120 VAC, 208-277. Burden: 10 mA at 120 VAC
Signal Input:	One switch-selectable Form A input. "Kin" is common return. Pulse Input is "Yin" input terminal, "pulled up" to +13VDC for pulse signal from meter."
Power Output:	Ten (10) sets of dry Form A contacts (K & Y) for energy pulses. The contacts are solid state rated at 125VAC/VDC at 100milliamps. The maximum power rating of the contacts is 800mW. Each output is factory fused at 1/10 amp. (3AG)
Contact On-State Resistance:	25 ohms maximum, 18 typical
Insulation Resistance:	50 megohms typical
Operate and Release Time:	2 to 3 milliseconds typical
Input/Output Isolation Voltage:	2500Vrms

MECHANICAL

Mounting:	Any position
Size:	7" wide, 9" high, 1.8" deep
Weight:	2 pounds

TEMPERATURE

Temperature Range:	-38° C to +70° C, -38.4° F to +158° F
Humidity:	0 to 98% non-condensing

AVAILABLE OPTIONS

Input Voltages:	Contact factory for other input voltages.
-----------------	---

SPR-112



SSI STANDARD

SPR-510 PULSE ISOLATION RELAY

DESCRIPTION

FUNCTIONAL SUMMARY

	IN	OUT
#	5	10
TYPE	2 Wire	2 Wire
FORM	A	A

The SPR-510 is a 5-channel pulse isolation relay designed for high-density pulse applications where up to five RPR-2PS or SPR-2 relays would be required. Ten isolated solid-state Form A (K & Y) dry-contact outputs are provided, two each from five Form A inputs. The SPR-510 relay contains standard-duty solid state outputs. The wetting voltage provided by the SPR-510 to the sending devices (typically electric meters) is +13 VDC. The SPR-510 may be used with meters having high or low voltage semiconductor outputs, or electro-mechanical output contacts (relays).

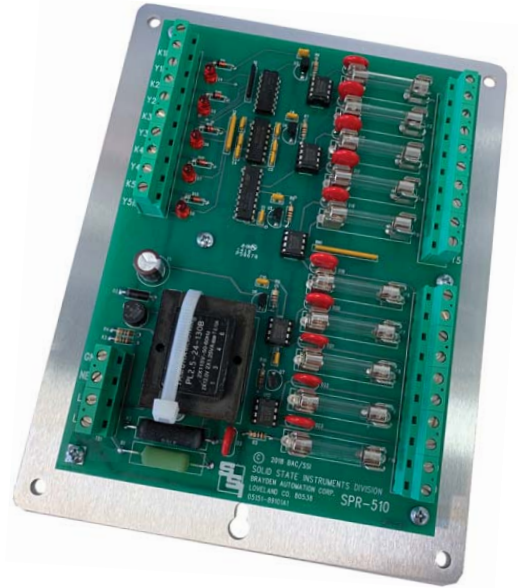

The SPR-510 relay's Form A inputs feature input filtering circuitry to prevent noise from false triggering the outputs. Pulses less than 18 mS are considered to be noise and will not be detected as a valid pulse. Once an input pulse, greater in length than 18 mS, is detected the corresponding outputs will be changed to match the state of the input.

Bright red and green LED indicators display the system's status at all times, thus allowing a rapid check of the system's performance without requiring any additional test equipment. The SPR-510's input and output terminal strip is a "Euro" type. When the stripped wire has been correctly installed in the terminal's slot, no conductive parts are exposed on the surface of the terminal strip, thus allowing the user maximum protection from accidental electrical shock. The "K" lead of the SPR-510's outputs are fused to prevent damage to the relays under almost any condition a user might cause such as excessive current, incorrect wiring, etc.

The SPR-510 has built-in MOV transient protection for the solid state relay contacts that eliminates the need for external protection. The SPR-510 is normally mounted inside another enclosure, suitable for the user's intended application. An optional NEMA 4X enclosure is available with the SPR-510 mounted on an internal mounting plate.

SPR-510



SSI STANDARD

SPR-510 PULSE ISOLATION RELAY

SPECIFICATIONS

ELECTRICAL

Power Input:	120 to 277 VAC. Burden: 10 mA at 120 VAC
Pulse Input:	Five Form A inputs. "Kin" is common return. Input has "Yin" input terminals are "pulled up" to +13VDC for pulse signal from meter
Pulse Output:	Ten (10) sets of dry Form C contacts (K & Y) for energy pulses. The contacts are solid state rated at 125VAC/VDC at 100milliamps. The maximum power rating of the contacts is 800mW. Each output is factory fused at 1/10 amp. (3AG)
Contact On-State Resistance:	25 ohms maximum, 18 ohms typical
Insulation Resistance:	50 megohms typical
Operate and Release Time:	2 to 3 milliseconds typical
Input/Output Isolation Voltage:	2500Vrms

MECHANICAL

Mounting:	Any position
Size:	7.00" wide, 9.00" high, 1.8" deep
Weight:	2 pounds

TEMPERATURE

Temperature Range:	-38° C to +70° C, -38.4° F to +158° F
Humidity:	0 to 98% non-condensing

AVAILABLE OPTIONS

Input Voltages:	<ul style="list-style-type: none">• 125 VDC input using DCS-1 Power Supply• +15-48VDC input using DCS-2 Power Supply• +12VDC & +24VDC/24VAC are also available. Contact Factory for other input voltages.
-----------------	---

All specifications are subject to change without notice.

SPR-510



SSI STANDARD B-SERIES

SPR-610 PULSE ISOLATION RELAY

DESCRIPTION

The SPR-610 is a 6-channel pulse isolation relay designed for high-density pulse applications where up to six RPR or SPR relays would be required. Twelve isolated solid-state Form A (K&Y) dry-contact outputs are provided, two each from four Form A inputs and one each for two Form A inputs. The SPR-610 relay contains standard-duty solid state outputs. The wetting voltage provided by the SPR-610 to the sending devices (typically electric meters) is +13 VDC. The SPR-610 may be used with meters having high or low voltage semiconductor outputs, or electro-mechanical output contacts (relays).

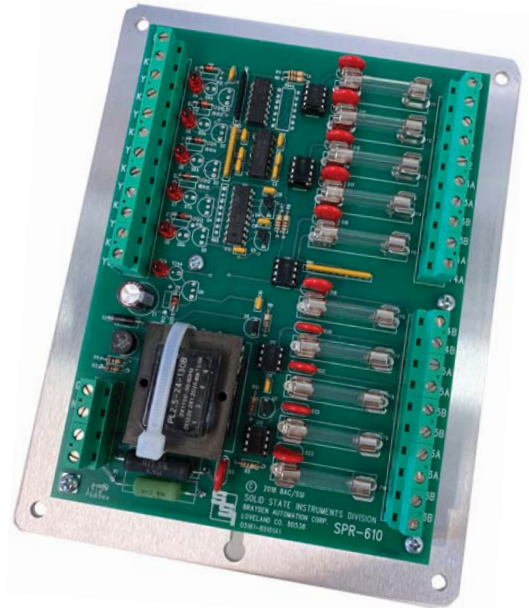

FUNCTIONAL SUMMARY

IN	OUT
6	10
2 Wire	2 Wire
A	A

TYPE
FORM

SPR-610

The SPR-610 relay's Form A inputs feature input filtering circuitry to prevent noise from false triggering the outputs. Pulses less than 18 mS are considered to be noise and will not be detected as a valid pulse. Once an input pulse, greater in length than 18 mS, is detected the corresponding outputs will be changed to match the state of the input.

Bright red and green LED indicators display the system's status at all times, thus allowing a rapid check of the system's performance without requiring any additional test equipment. The SPR-610's input and output terminal strip is a "Euro" type. When the stripped wire has been correctly installed in the terminal's slot, no conductive parts are exposed on the surface of the terminal strip, thus allowing the user maximum protection from accidental electrical shock. The "K" lead of the SPR-610's outputs are fused to prevent damage to the relays under almost any condition a user might cause such as excessive current, incorrect wiring, etc.

The SPR-610 has built-in MOV transient protection for the solid state relay contacts that eliminates the need for external protection. The SPR-610 is normally mounted inside another enclosure, suitable for the user's intended application. An optional NEMA 4X enclosure is available with the SPR-610 mounted on an internal mounting plate.



SSI STANDARD B-SERIES

SPR-610 PULSE ISOLATION RELAY

SPECIFICATIONS

ELECTRICAL

Power Input:	120 to 277 VAC. Burden: 10 mA at 120 VAC
Pulse Input:	Six Form A inputs. "Kin" is common return. Input has "Yin" input terminals are "pulled up" to +13VDC for pulse signal from meter
Pulse Output:	Twelve (12) Form A dry contacts (K & Y) for energy pulses. The contacts are solid state rated at 125VAC/VDC at 100milliamps. The maximum power rating of the contacts is 800mW. Each output is factory fused at 1/10 amp. (3AG)
Contact On-State Resistance:	25 ohms maximum, 18 ohms typical
Insulation Resistance:	50 megohms typical
Operate and Release Time:	2 to 3 milliseconds typical
Input/Output Isolation Voltage:	2500Vrms

MECHANICAL

Mounting:	Any position
Size:	7.00" wide, 9.00" high, 1.8" deep
Weight:	2 pounds

TEMPERATURE

Temperature Range:	-38° C to +70° C, -38.4° F to +158° F
Humidity:	0 to 98% non-condensing

AVAILABLE OPTIONS

Input Voltages:	<ul style="list-style-type: none">• 125 VDC input using DCS-1 Power Supply• +15-48VDC input using DCS-2 Power Supply• +12VDC & +24VDC/24VAC are also available. Contact Factory for other input voltages.
-----------------	---

All specifications are subject to change without notice.

SPR-610



SSI STANDARD

RTR-22+ HIGH-SPEED WATER & GAS METER RELAY

DESCRIPTION

The RTR-22+ high-speed pulse isolation relay is designed to interface two pulse channels from water or gas meters to other systems. Two independent channels, each with their own Form A input and a corresponding Form A (K & Y) isolated solid-state dry contact output. Most water and gas meters with a pulse output will interface to the RTR-22+'s input, whether it is an open-collector transistor, open drain FET, MOSFET solid state relay, read switch or a dry-contact relay. The input is activated when the input (Y) is switched from its "pulled up" state to ground (K) for at least a minimum pulse time. Four input filter times are field-selectable: 50 microseconds, .5, 5 or 20 milliseconds.



When the RTR-22+ relay is inserted in the two-conductor cable between the water or gas meter and the remote equipment, it provides a replicated signal to the remote equipment, provides a separate isolated (dry contact) Form A contact closure for use with customer-owned monitoring equipment.

Typical applications involve pulse counting, monitoring and recording of water or gas usage. Other applications include interfaces between utility metering devices and customer-owned building automation systems, control and monitoring systems, usage recorders, automated meter reading systems and supervisory control and data acquisition systems (SCADA). Bright yellow LED lamps, one for each of the RTR-22+'s inputs, indicate the channels' input status at all times, thus allowing the field technician to visually observe pulses being received from the water or gas meter. A bright green LED visually shows each channel's output status.

The microcontroller-based RTR-22+ checks each incoming pulse for its duration. If the incoming pulse is less than the input filter time selected, the RTR-22+ assumes the incoming pulse to be noise and it is rejected. If used in a very noisy environment this "pulse acceptance window" may be lengthened or shortened as needed to reject noise by selecting a different input filter time.

The RTR-22+ has two modes on the output operation: normal and fixed. The normal mode's output follows the input so the duty cycle on the output is a mirrored image of the input and timing is approximately the same. In the fixed mode, each channel has an output closure time selected, either 50, 100, 200, or 500 milliseconds. Pulses can either be "stretched" or shortened to suit the receiving equipment. In the event that the input pulse rate exceeds the output time such that input pulses are arriving from the meter faster than the output can handle, the microcontroller stores up to 255 pulses and outputs them in a 50/50 duty cycle as soon as possible so that no pulses are lost. If more than 255 pulses are stored, then a RED LED lights indicating a count register overflow.

Input and output terminals are "Euro" type connector for easy field wiring and excellent isolation. The "K" lead of the RTR-22+'s outputs are fused and have built-in transient protection for the solid-state relay's. All component parts that have power applied to them, with the exception of the input/output terminal strip are enclosed in a polycarbonate cover for maximum user protection. The mounting base plate is made of polycarbonate and offers excellent electrical insulation between the circuit and the mounting surface. RTR-22+ models are designed for mounting in an electrical enclosure appropriate for the application and operating environment.

FUNCTIONAL SUMMARY

	IN	OUT
#	2	2
TYPE	2 Wire	2 Wire
FORM	A	A
SPECIAL FEATURES	<ul style="list-style-type: none"> • Up to 200 pulses/second • Open Collector transistor or dry contact switch input 	

RTR-22+

SOLID STATE INSTRUMENTS A Product Family Owned by RADIAN RESEARCH

3852 Fortune Dr. • Lafayette, IN • Ph: 765-449-5500 • Fax: 765-448-4614

www.radianresearch.com



SSI STANDARD

RTR-22+ HIGH-SPEED WATER & GAS METER RELAY

SPECIFICATIONS

ELECTRICAL

Power Input:	90-130, 208 to 277 VAC. Burden: <10 mA at 120 VAC
Pulse Inputs:	Two Form A (K & Y) pulse inputs with a +8 to +13VDC wetting voltage. Current source inputs provide for fixed current through meter contact.
Output:	Two sets of dry Form A (K & Y) contacts. Outputs are activated (closed) for a nominal 50, 100, 200, or 500mS following a valid input pulse if fixed mode is selected. The contacts are solid state "no bounce" relays rated at 250 VAC/VDC @ 1/10 Amp. The maximum rating of the contacts is 800mW. Factory fused at 1/10 amp. (3AG)
Contact On-State Resistance:	25 ohms maximum, 18 ohms typical
Operate and Release Time:	Turn On: 5 mS maximum, 2-3 mS typical Turn Off: 5 mS maximum, 2-3 mS typical
Input/Output Isolation Voltage:	2500 Vrms

MECHANICAL

Mounting:	Any position.
Size:	3.27" wide, 5.65" high, 1.50" deep
Weight:	13 ounces

TEMPERATURE

Temperature Range:	-38° C to +70° C, -36.4° F to +158° F
Humidity:	0 to 98% non-condensing

AVAILABLE OPTIONS

Input Voltages:	125 VDC input using the DSC-1 Power Supply. 15-48VDC input using the DCS-2 Power Supply. Contact factory for other input voltages.
Input Configurations:	Sourced Voltage inputs are available which receive a voltage from +3 to +48VDC from external systems.

All specifications are subject to change without notice.

RTR-22+



SSI STANDARD

RTR-2C ULTRA HIGH-SPEED WATER & GAS METER RELAY

DESCRIPTION

The RTR-2C Ultra High-Speed Repeating Pulse Relay using a high-speed digital signal processor to interface high-speed pulses from water and gas meters to RTU's, meters, counters or similar telemetry. The RTR-2C is configured with one Form A (2-wire) pulse input and two corresponding Form A (KY) isolated, solid-state dry contact pulse outputs. Most water and gas meters with standard pulse outputs are directly compatible to the RTR-2C's input, whether it is an open-collector transistor, open-drain FET, MOSFET solid state relay, or read relay. The input is activated when the input (Yin) is switched from its "pulled up" state, down to ground (Kin) for at least a minimum pulse debounce time.



Eight input filter times are field-selectable: 25, 50, 100, 200 or 500 microseconds, or 1, 5 or 20 milliseconds. With the appropriate filtering time, noise that could be counted as pulses is ignored.

When the RTR-2C relay is inserted between the water or gas meter and the remote equipment, it provides two duplicated pulse outputs, providing pulses to two pieces of remote equipment while electrically isolating them so as to eliminate problems with noise or intermingling of circuits. The RTR-2C also provides an output terminal with 12V at 20mA for powering the water or gas meter if required.

Typical applications involve pulse counting, monitoring and recording of water or gas usage. Other applications include interfaces between utility metering devices and customer-owned building automation systems, control and monitoring systems, usage recorders, automated meter reading systems and supervisory control and data acquisition systems (SCADA). Bright yellow LED lamp, on the RTR-2C's input indicates the input's status at all times, thus allowing the field technician to visually observe pulses being received from the water or gas meter. A bright green LED visually shows the outputs' status. No specialized test equipment is required. The microcontroller-based RTR-2C checks each incoming pulse for its duration. If the incoming pulse is less than the input filter time selected, the RTR-2C assumes the incoming pulse to be noise and it is rejected. Thus, any valid pulse rate of 200 pulses per second or less is accepted while static and induced high frequency noise is rejected. If used in a very noisy environment this "pulse acceptance window" may be lengthened or shortened as needed to reject noise by selecting a different input filter time. The RTR-2C also includes a test mode with diagnostics to determine if very, very short pulses are received.

The RTR-2C has two modes on the output operation: normal and fixed. The normal mode's outputs follows the input so the duty cycle on the output is a mirror image of the input and timing is the same. In the fixed mode, an output closure time is selected and the output closes for a fixed time period. The RTR-2C has selectable output closure times of 5, 10, 20, 50, 100, 200, 500 or 1000 milliseconds, regardless of the input pulse's duration. The output duration time is easily selected on the RTR-2C's DIP switch. In this way, pulses can either be "stretched" or shortened to suit the receiving equipment. In the event that the input pulse rate exceeds the output time such that input pulses are arriving from the meter faster than the output can handle, the microcontroller stores up to 65,565 pulses and outputs them in a 50/50 duty cycle as soon as possible so that no pulses are lost. If more than 65,565 pulses are stored, then the RED LED lights indicating a count register overflow condition.

The RTR-2C therefore provides a contact closure of sufficient and fixed length to the remote equipment & allows the revenue water or gas meter display to operate normally. The input and output terminal strip is a "Euro" type connector for easy field wiring and excellent isolation. The "K" leads of the RTR-2C's outputs are fused to prevent damage to the relay under almost any conditions a user might cause such as excessive current, incorrect wiring, etc. RTR-2C models have built-in transient protection for the solid-state relay's contacts that eliminates the need for external or off-the-board transient suppressors.

FUNCTIONAL SUMMARY

	IN	OUT
#	1	2
TYPE	2 Wire	2 Wire
FORM	A	A
SPECIAL FEATURES	<ul style="list-style-type: none"> • Up to 200 pulses/second • Open Collector transistor or dry contact switch input 	

RTR-2C

SOLID STATE INSTRUMENTS A Product Family Owned by RADIAN RESEARCH

3852 Fortune Dr. • Lafayette, IN • Ph: 765-449-5500 • Fax: 765-448-4614

www.radianresearch.com



SSI STANDARD

RTR-2C HIGH-SPEED WATER & GAS METER RELAY

SPECIFICATIONS

ELECTRICAL

Power Input:	90-130, 208 to 277 VAC. Burden: <10 mA at 120 VAC
Pulse Inputs:	Two Form A (K & Y) pulse inputs with a +8 to +13VDC wetting voltage. Current source inputs provide for fixed current through meter contact.
Output:	Two sets of dry Form A (K & Y) contacts. Outputs are activated (closed) for a nominal 5,10,20, 50, 100, 200, 500mS, or 1000mS following a valid input pulse as selected. The contacts are solid state “no bounce” relays rated at 120 VAC/VDC @ 1/10 Amp. The maximum rating of the contacts is 800mW. Factory fused at 1/10 amp. (3AG or AGC)
Contact On-State Resistance:	25 ohms maximum, 18 ohms typical
Operate and Release Time:	Turn On: 5 mS maximum, 2-3 mS typical Turn Off: 5 mS maximum, 2-3 mS typical
Input/Output Isolation Voltage:	2500 Vrms

MECHANICAL

Mounting:	Any position.
Size:	3.27” wide, 5.65” high, 1.50” deep
Weight:	13 ounces

TEMPERATURE

Temperature Range:	-38° C to +70° C, -38.4° F to +158° F
Humidity:	0 to 98% non-condensing

AVAILABLE OPTIONS

Input Voltages:	125 VDC input using the DSC-1 Power Supply. 15-48VDC input using the DCS-2 Power Supply. Contact factory for other input voltages.
Input Configurations:	Sourced Voltage inputs are available which receive a voltage from +3 to +48VDC from external systems.

RTR-2C



SSI STANDARD

RTR-2SP HIGH-SPEED WATER & GAS METER RELAY

B-SERIES

DESCRIPTION

The RTR-2SP High-Speed Repeating Pulse Relay is designed to interface pulse output from water or gas meters to other systems. The RTR-2SP is configured with a Form A input and two Form A (KY) isolated solid-state dry contacts and features a Low Voltage power supply input ranging from 13 to 35VDC. Most water and gas meters with a pulse output will directly interface to the RTR-2SP's input, whether it is an open-collector transistor, open drain FET, MOSFET solid state relay, reed reed switch or a dry-contact relay. The input is activated when the input (Y) is switched from its "pulled-up" state to ground (K) for at least a minimum pulse time. Four input filter times are field-selectable: 50 microseconds, .5, 5 or 20 milliseconds.



FUNCTIONAL SUMMARY

	IN	OUT
#	1	2
TYPE	2 Wire	2 Wire
FORM	A	A
SPECIAL FEATURES	<ul style="list-style-type: none"> • Up to 200 pulses/second • Open Collector transistor or dry contact switch input 	

When the RTR-2SP relay is inserted in the two-conductor cable between the water or gas meter and the remote equipment, the RTR-2SP provides a replicated signal to the remote equipment, and also provides a separate isolated (dry contact) Form A contact for use with customer-owned monitoring equipment.

Typical applications involve pulse counting, monitoring and recording of water or gas usage. Other applications include interfaces between utility metering devices and customer-owned building automation systems, control and monitoring systems, usage recorders, automated meter reading systems and supervisory control and data acquisition systems (SCADA). Bright yellow LED lamps, one the RTR-2SP' inputs indicate the input's status at all times, thus allowing the field technician to visually observe pulses being received from the water or gas meter. A bright green LED visually shows the output's status. No specialized test equipment is required. The microcontroller-based RTR-2SP checks each incoming pulse for its duration. If the incoming pulse is less than the input filter time selected, the RTR-2SP assumes the incoming pulse to be noise and it is rejected. Thus, any valid pulse rate of 200 pulses per second or less is accepted while static and induced high frequency noise is rejected. If used in a very noisy environment this "pulse acceptance window" may be lengthened or shortened as needed to reject noise by selecting a different input filter time.

The RTR-2SP has two modes on the output operation: normal and fixed. The normal mode's output follows the input so the duty cycle on the out is a mirrored image of the input and timing is approximately the same. In the fixed mode, an output closure time is selected and the output closes for a fixed time period. Each channel of the RTR-2SP has an independently selectable output closure time 5, 10, 20, 50, 100, 200, 500, or 1,000 milliseconds, regardless of the input pulse's duration. The output duration time may be easily selected on a DIP switch. In this way, pulses can either be "stretched" or shortened to suit the receiving equipment. In the event that the input pulse rate exceeds the output time such that input pulses are arriving from the meter faster than the output can handle, the microcontroller stores up to 65,535 pulses and outputs them in a 50/50 duty cycle as soon as possible so that no pulses are lost. If more than 65,535 pulses are stored, then a RED LED lights indicating a count register overflow.

The RTR-2SP therefore provides a contact closure of sufficient and fixed length to the remote equipment & allows the revenue water or gas meter display to operate normally. The input and output terminal strip is a "Euro" type connector for easy field wiring and excellent isolation. The "K" lead of the RTR-2SP's outputs are fused to prevent damage to the relay under almost any conditions a user might cause such as excessive current, incorrect wiring, etc. RTR-2SP models have built-in transient protection for the solid-state relay's contacts that eliminates the need for external or off-the-board transient suppressors.

RTR-2SP



SSI STANDARD

RTR-2SP HIGH-SPEED WATER & GAS METER RELAY

B-SERIES

SPECIFICATIONS

ELECTRICAL

Power Input:	+13-35VDC
Pulse Inputs:	One Form A (KY) pulse inputs with a +8 to +13VDC wetting voltage. Current source inputs provide for fixed current through meter contact at approximately 10-20mA.
Output:	Two sets of dry Form A (K & Y) contacts. Outputs are activated (closed) for a nominal 5, 10, 20, 50, 100, 200, 500 or 1000mS following a valid input pulse as selected. The contacts are solid state "no bounce" relays rated at 250 VAC/VDC @ 1/10 Amp. The maximum rating of the contacts is 800mW. Factory fused at 1/10 amp. (3AG)
Contact On-State Resistance:	25 ohms maximum, 18 ohms typical
Operate and Release Time:	Turn On: 5 mS maximum, 2-3 mS typical Turn Off: 5 mS maximum, 2-3 mS typical
Input/Output Isolation Voltage:	2500 Vrms

MECHANICAL

Mounting:	Any position.
Size:	3.27" wide, 5.65" high, 1.50" deep
Weight:	13 ounces

TEMPERATURE

Temperature Range:	-38° C to +70° C, -38.4° F to +158° F
Humidity:	0 to 98% non-condensing

AVAILABLE OPTIONS

Input Voltages:	Contact factory for other input voltages. *Sourced Voltage inputs are available which receive a voltage from +3 to +48VDC from external systems.
Input Configurations:	*Super low current (FET transistor) input for input currents up to 1mA.

RTR-2SP



SSI STANDARD

DPR-1 HIGH-SPEED DIVIDING PULSE RELAY

DESCRIPTION

The DPR-1 is a high-speed dividing pulse relay designed specifically for water and gas meter for pulse applications up to 200 pulses per second. It provides two sets of isolated “dry” 2-wire Form A contacts (K, Y, & Z) from a 2-wire (Form A) pulse input. The output is divided by a user-selected number, ranging from 2 to 4096. The desired division ratio is selected with a single jumper shunt mounted on the relay’s board and is easily adjustable by hand or with a set of needle nose pliers. The DPR-1 counts the input pulses for division only when a correct and valid sequence of pulses occur. Bright yellow and green LED lamps indicate the input and output status of the system at all times thus allowing a rapid visual check-out of the system’s performance without requiring any additional test equipment.



The input and output circuits’ terminal strip are “Euro” type connectors. The K leads of each of the DPR-1’s isolated outputs are fused to prevent damage to the relays under almost any condition a user might subject it to such as excessive current, voltage, or incorrect wiring. The DPR-1 provides a “pulled up” sense voltage of approximately +13 VDC on the Y input terminal to the sending device’s dry contact output. The K terminal is system ground allowing the use of standard mechanical, electro-mechanical, dry contact switches or solid state open-collector NPN or open-drain FET transistor pulse initiators. The DPR-1 has built-in MOV transient protection for the solid-state relay contacts that eliminates the need for external or off-the-board transient suppressors. All component parts of the DPR-1, which have power applied to them with the exception of the input/output terminal strips, are enclosed in a polycarbonate cover for maximum user protection. The mounting base plate is also made of polycarbonate and offers excellent electrical insulation. The DPR-1 is intended for mounting in an enclosure appropriate for the application and the operating environment.

The DPR-1 may be powered from a 120VAC source or by either of SSI’s optional DCS power supplies. Contact the factory for more information.

FUNCTIONAL SUMMARY

	IN	OUT
#	1	2
TYPE	2 Wire	2 Wire
FORM	A	A

TYPE
FORM

DPR-1



SSI STANDARD

DPR-1 HIGH SPEED DIVIDING PULSE RELAY

SPECIFICATIONS

ELECTRICAL

Power Input:	120, 208-277 VAC. Burden: 3.5 VA
Pulse Input Voltage:	+13VDC "pulled-up" on Yin terminal. Common return is Kin terminal.
Pulse Output:	Two sets of dry Form "A" contacts (K & Y). Contacts are solid-state relays rated at 250VAC/VDC, 100 mA MAX. The maximum power dissipation rating of the contacts is 800 mW. Factory fused at 1/10 amp. (3AG)
Contact Resistance:	25 ohms maximum, 18 ohms typical
Operate and Release Time:	2.5 milliseconds max. operate (turn-on) 2.5 milliseconds max. release (turn off)
Input/Output Isolation Voltage:	2500Vrms

MECHANICAL

Mounting:	Any position.
Size:	3.27" wide, 5.65" high, 1.50" deep
Weight:	12 ounces

TEMPERATURE

Temperature Range:	-38° C to +70° C, -36.4° F to +158° F
Humidity:	0 to 98% non-condensing

AVAILABLE OPTIONS

Input Voltages:	125VDC or 15-48VAC. Contact Factory.
Enclosure:	NEMA 3R or 4X

DPR-1



SSI STANDARD

DPR-2 PROGRAMMABLE DIVIDING PULSE RELAY

DESCRIPTION

The DPR-2 is a programmable microcontroller-based, high-speed dividing pulse relay designed to provide two independent “dry” 2-wire Form A contacts (K & Y) from a 2-wire Form A pulse input. An output pulse occurs when a specified number of input pulses have been received. The divider’s ratio of input to output pulses may be set between .00001 and 100,000. Using floating point math, the DPR-2 can be configured to scale input to output pulses to an exact ratio desired.



FUNCTIONAL SUMMARY

	IN	OUT
#	1	2
TYPE	2 Wire	2 Wire
FORM	A	A

The DPR-2 is a programmable microcontroller-based, high-speed dividing pulse relay designed to provide two independent “dry” 2-wire Form A contacts (K & Y) from a 2-wire Form A pulse input. An output pulse occurs when a specified number of input pulses have been received. The divider’s ratio of input to output pulses may be set between .00001 and 100,000. Using floating point math, the DPR-2 can be configured to scale input to output pulses to an exact ratio desired.

The DPR-2 has two modes of operation, Pulse Divider mode and Pulse Conversion mode. In the Pulse Divider mode, the number of input pulses is specified to produce an output pulse, without regard to the specific value of the pulse, only the number of pulses. In Pulse Conversion mode, the value of a pulse is entered into the system. Upon a pulse being received, the exact units of accumulated water, electricity or gas consumed are added to an accumulator register. Units are programmable are either gallons, kilowatt-hours or CCF’s (hundred cubic feet). An output pulse value is programmed into the DPR-2 to the desired value in the same units as the input units. Once the accumulator register reaches the desired value of units, an output pulse is generated. Extremely precise conversions of values can be accomplished using the pulse conversion mode.

Output pulses may be set in length from 5 mS to 1000mS. In addition, the minimum-off time between pulses is also be set. This keeps pulses from being outputted too rapidly to the receiving equipment. In the event that power is lost while there is a pulse count in the accumulator register, the pulse count is stored in non-volatile EEPROM memory. Upon power-up, the pulse count is entered into the register and operation resumed.

If the number of output pulses exceeds the timing constraints of the pulse on time and minimum-off time, the microcontroller will store up to 65,383 output pulses in a cue waiting to be output. This output pulse number is also stored in EEPROM memory, so that no pulses are lost.

The DPR-2 microcontroller checks the input pulse for valid timing or “debounce” to make sure that pulses are of sufficient length to be legitimate pulses. Thus, input pulses are counted only when valid pulses occur, assuring a high degree of noise rejection. Bright red and green LED lamps indicate the input and output status, respectively, all times thus allowing a rapid visual check-out of the system’s performance without requiring any additional test equipment.

The DPR-2 can be programmed using a USB A-B Programming cable with either a terminal program, like TeraTerm, Puddy or HyperTerminal, or with SSI’s Universal Programmer software available on the website.

The input and output circuits’ terminal strip are “Euro” type connectors. The K leads of each of the DPR-2’s isolated outputs are fused to prevent damage to the relays under almost any condition a user might subject it to such as excessive current, voltage, or incorrect wiring. The DPR-4 provides a “pulled up” sense voltage of approximately +13 VDC on the Yin terminal of the input to the external sending contacts. The K terminal is system ground allowing the use of standard electro-mechanical, dry contact switches or solid-state open-collector transistor or MOS-FET pulse initiators. The DPR-2 has built-in MOV transient protection for the solid-state relay contacts that eliminates the need for external or off-the-board transient suppressors. All component parts of the DPR-2, which have power applied to them with the exception of the input/output terminal strips and the USB programming port connector, are enclosed in a polycarbonate cover for maximum user protection. The mounting base is also made of polycarbonate and offers excellent electrical insulation. Mounting tabs on the base plate allow the DPR-2 to be mounted in an appropriate enclosure for the application and the operating environment.

DPR-2



SSI STANDARD

DPR-2 PROGRAMMABLE DIVIDING PULSE RELAY

SPECIFICATIONS

ELECTRICAL

Power Input:	120 VAC, 208-277 VAC; Burden: 10 mA at 120 VAC
Pulse Input Voltage:	+13VDC “pulled-up” on Yin terminal. Common return is Kin terminal.
Pulse Output:	Two sets of dry Form “A” contacts (K & Y). Contacts are solid-state relays rated at 250VAC/VDC, 100 mA MAX. The maximum power dissipation rating of the contacts is 800 mW. Factory fused at 1/10 amp. (3AG)
Contact Resistance:	25 ohms maximum, 18 ohms typical
Operate and Release Time:	1 milliseconds max. operate (turn-on) 1 milliseconds max. release (turn off)
Input/Output Isolation Voltage:	3500Vrms

MECHANICAL

Mounting:	Any position.
Size:	3.50” wide, 7.20” high, 1.50” deep
Weight:	1 pound

TEMPERATURE

Temperature Range:	-38° C to +70° C, -38.4° F to +158° F
Humidity:	0 to 98% non-condensing

AVAILABLE OPTIONS

Input Voltages:	12VDC, 24VAC/VDC, 15-48VDC, 125VDC; For others contact factory
Enclosure:	NEMA 3R or 4X

DPR-2



SSI STANDARD

DPR-4 HIGH SPEED DIVIDING PULSE RELAY

DESCRIPTION

The DPR-4 is a microcontroller-based, high-speed dividing pulse relay designed to provide two sets of isolated “dry” 2-wire Form A contacts (K & Y) from a field selectable 2-wire Form A pulse input which have been divided by a user-selected count number. The divider’s ratio of input pulses to output pulses may be set between 1 and 10,000. Selection of the desired division ratio is made by a setting a BCD rotary selection switch (0-9) and the appropriate multiplication jumper, either X10, X100 or X1000. The output may be configured as either toggle or pulse. In toggle mode, the output changes to the opposite state when the input preset count is reached. In pulse mode, a 100mS output pulse is generated when the preset count is reached. Pulse count is stored in non-volatile EEPROM memory so that any power failure will not lose the current pulse count. In the event that the divider ratio is low and pulse rate is high in the pulse output mode, the microcontroller will store up to 255 output pulses waiting to be output. This output pulse number is also stored in EEPROM memory, so that no pulses are lost.



The DPR-4 microcontroller checks the input pulse for valid timing, and counts the input pulses for division only when valid pulses occur, thus assuring a high degree of noise rejection. Bright red and green LED lamps indicate the input and output status, respectively, all times thus allowing a rapid visual check-out of the system’s performance without requiring any additional test equipment.

The input and output circuits’ terminal strip are “Euro” type connectors. The K leads of each of the DPR-4’s isolated outputs are fused to prevent damage to the relays under almost any condition a user might subject it to such as excessive current, voltage, or incorrect wiring. The DPR-4 provides a “pulled up” sense voltage of approximately +13 VDC on the Y and Z terminals of the input to the external sending contacts. The K terminal is system ground allowing the use of standard electro-mechanical, dry contact switches or solid-state open-collector transistor or MOS-FET pulse initiators. The DPR-4 has built-in MOV transient protection for the solid-state relay contacts that eliminates the need for external or off-the-board transient suppressors. All component parts of the DPR-4, which have power applied to them with the exception of the input/ output terminal strips and the divider switches, are enclosed in a polycarbonate cover for maximum user protection. The mounting base plate is also made of polycarbonate and offers excellent electrical insulation. Mounting tabs on the base plate allow the DPR-4 to be mounted in an appropriate enclosure for the application and the operating environment.

FUNCTIONAL SUMMARY

	IN	OUT
#	1	2
TYPE	2 Wire	2 Wire
FORM	A	A

TYPE
FORM

DPR-4



SSI STANDARD

DPR-4 HIGH SPEED DIVIDING PULSE RELAY

SPECIFICATIONS

ELECTRICAL

Power Input:	120,208-277 VAC; Burden:10 mA at 120 VAC
Pulse Input Voltage:	+13VDC “pulled-up” on Yin and Zin terminal. Common return is Kin terminal.
Pulse Output:	Two sets of dry Form “A” contacts (K & Y) for time or energy pulses. The contacts are solid-state relays rated at 250VAC/VDC @ 100 mA MAX. The maximum rating of the contacts is 800 mW. Factory fused at 1/10 amp. (3AG)
Contact Resistance:	25 ohms maximum, 18 ohms typical
Operate and Release Time:	5 milliseconds max. operate (turn-on) 5 milliseconds max. release (turn off)
Input/Output Isolation Voltage:	2500Vrms

MECHANICAL

Mounting:	Any position.
Size:	3.27” wide, 5.65” high, 1.50” deep
Weight:	12 ounces

TEMPERATURE

Temperature Range:	-38° C to +70° C, -36.4° F to +158° F
Humidity:	0 to 98% non-condensing

AVAILABLE OPTIONS

Input Voltages:	Contact Factory
Enclosure:	NEMA 3R or 4X

DPR-4



SSI ELITE

SPR-3E SELF-CONTAINED PULSE ISOLATION RELAY

DESCRIPTION

The SPR-3E self-contained pulse isolation relay is designed to provide three sets of isolated dry, solid state Form C (K, Y, & Z) contacts from a single field-selectable Form A or C input in a NEMA 4X enclosure for complete weather proof operation. The SPR-3E utilizes solid state (silicon) outputs and is functionally equivalent to the SPR-3, but designed for outdoor operation. The wetting or "sense" voltage of +13VDC is available on the "Yin" and "Zin" inputs, and is "pulled up." The "Kin" terminal is the common return. The SPR-3E is compatible with most meters having mechanical or high or low voltage semiconductor pulse outputs and operates over a wide voltage range for maximum flexibility.



FUNCTIONAL SUMMARY

	IN	OUT
#	1	3
TYPE	2 or 3 Wire	3-wire
FORM	A or C	C

SPR-3E

Typical applications include interfaces between utility metering devices and customer-owned energy control systems, demand response applications, pulse recorders and supervisory control system (SCADA) interfaces. The SPR-3E's input has a switch-selectable Form A or Form C input and input filtering circuitry to prevent noise from triggering the output. Any pulses less than 18mS are considered to be noise and will not be detected as a valid pulse. Once an input pulse greater than 18mS in length is detected, the outputs will be changed according to the status of the input, thus eliminating any false pulses.

Bright red and green LED indicators display the system status at all times, thus allowing a rapid check of the system's performance without requiring any additional test equipment. The SPR-3E's input and output terminal strip is a "Euro" type connector. When the stripped wire has been correctly installed in the terminals "slot", no conductive parts are exposed on the surface of the terminal strip, thus allowing the user maximum protection from accidental electrical shock. Each "K" lead of the SPR-3E's outputs is fused to prevent damage to the relays under almost any condition users might cause such as excessive current, incorrect wiring, etc.

The SPR-3E has built-in MOV transient protection for the solid state (silicon) relays contacts which eliminates the need for external protection. The SPR-3E's tough polycarbonate enclosure offers excellent electrical insulation and measures approximately 9" x 8" x 3", allowing ample wiring room for field terminations. All component parts which have power applied to them, with the exception of the input/output terminal strip are enclosed with an acrylic cover for maximum protection.



SSI ELITE

SPR-3E SELF CONTAINED PULSE ISOLATION RELAY

SPECIFICATIONS

ELECTRICAL

Power Input:	120, 208-277 VAC. Burden: 10mA at 120 VAC
Pulse Input:	One switch-selectable Form A or Form C input. "Kin" is common return. Input has "Yin" and "Zin" input terminals for pulse signal from meter. "Yin" terminal used for 2-Wire mode. Both used for 3-Wire.
Pulse Output:	Three sets of dry Form C contacts (K, Y, & Z) for energy pulses. The contacts are rated at 125VAC/VDC at 100milliamps. The maximum rating of the contacts is 800mW. Each output is factory fused at 1/10 amp. (3AG)
Contact On-State Resistance:	25 ohms maximum, 18 typical
Operate and Release Time:	2 to 3 milliseconds typical
Input/Output Isolation Voltage:	2500Vrms

MECHANICAL

Mounting:	Any position.
Interior:	8.00" wide, 9.00" high, 2.00" deep
Exterior:	10.00" wide, 11.00 high, 3.51" deep
Weight:	2.5 pounds

TEMPERATURE

Temperature Range:	-38° C to +70° C, -36.4° F to +158° F
Humidity:	0 to 98% non-condensing

AVAILABLE OPTIONS

Input Voltages:	125 VDC input using the DSC-1 Power Supply. Contact factory for other input voltages.
-----------------	---

SPR-3E



SSI ELITE

SPR-24E SELF-CONTAINED PULSE ISOLATION RELAY

DESCRIPTION

The SPR-24E self-contained pulse isolation relay is designed to provide four sets of isolated dry, solid state Form C (K, Y, & Z) contacts from two field-selectable Form A or C inputs in a NEMA 4X enclosure. The SPR-24E utilizes solid state (silicon) outputs and is functionally equivalent to the SPR-24, but designed for outdoor operation. Each input's wetting or "sense" voltage of +13VDC is available on each "Yin" and "Zin" inputs, and is "pulled up." The "Kin" terminal is the common return. The SPR-24E is compatible with most meters having mechanical, electromechanical or solid state pulse outputs and operates over a wide voltage range for maximum flexibility.



Typical applications include interfaces between utility metering devices and customer-owned energy control systems, demand response applications, pulse recorders and supervisory control system (SCADA) interfaces. The SPR-24E's input has a switch-selectable Form A or Form C input and input filtering circuitry to prevent noise from triggering the output. Any pulses less than 18mS are considered to be noise and will not be detected as a valid pulse. Once an input pulse greater than 18mS in length is detected, the outputs will be changed according to the status of the input, thus eliminating any false pulses.

Bright red and green LED indicators display the system status for both input channels at all times, thus allowing a rapid check of the system's performance without requiring any additional test equipment. The SPR-24E's input and output terminal strip allows maximum protection from accidental electrical shock. Each output's "K" lead is fused to prevent damage to the relays under almost any condition users might cause such as excessive current, incorrect wiring, etc.

The SPR-24E has built-in MOV transient protection for the solid state (silicon) relays contacts which eliminates the need for external protection. The SPR-24E's tough polycarbonate enclosure offers excellent electrical insulation and measures approximately 9" x 8" x 2", allowing ample wiring room for field terminations. All component parts which have power applied to them, with the exception of the input/output terminal strip are enclosed with an acrylic cover for maximum protection.

FUNCTIONAL SUMMARY

	IN	OUT
#	2	4
TYPE	2 or 3 Wire	3-wire
FORM	A or C	C

TYPE
FORM

SPR-24E



SSI ELITE

SPR-24E SELF-CONTAINED PULSE ISOLATION RELAY

SPECIFICATIONS

ELECTRICAL

Power Input:	120, 208-277 VAC. Burden: 10mA at 120 VAC
Pulse Input:	Two switch-selectable Form A or Form C input. "Kin" is common return. Inputs have "Yin" and "Zin" input terminals for pulse signals from meter. "Yin" terminal used for 2-Wire mode. Both used for 3-Wire.
Pulse Output:	Four sets of dry Form C contacts (K, Y, & Z) for energy pulses. The contacts are rated at 125VAC/VDC at 100milliamps. The maximum rating of the contacts is 800mW. Each output is factory fused at 1/10 amp. (3AG)
Contact On-State Resistance:	25 ohms maximum, 18 typical
Operate and Release Time:	2 to 3 milliseconds typical
Input/Output Isolation Voltage:	2500Vrms

MECHANICAL

Mounting:	Any position.
Interior:	8.00" wide, 9.00" high, 2.00" deep
Exterior:	10.00" wide, 11.00 high, 3.51" deep
Weight:	2.5 pounds

TEMPERATURE

Temperature Range:	-38° C to +70° C, -36.4° F to +158° F
Humidity:	0 to 98% non-condensing

AVAILABLE OPTIONS

Input Voltages:	125 VDC input using the DSC-1 Power Supply. Contact factory for other input voltages.
-----------------	---

SPR-24E



SSI ELITE

RPR-1PS PULSE ISOLATION RELAY

B-SERIES
FORMERLY THE RPR-1PS A-SERIES

DESCRIPTION

The RPR-1PS pulse isolation relay is designed to provide a single isolated solid state Form C (K, Y, & Z) contact from a single Form C input. The RPR-1PS supplies its own sense voltage to the pulse sending unit, usually an electric meter's pulse initiator.

Typical applications include interfaces between utility metering devices and customer-owned energy control systems, demand recorder applications, and supervisory control systems (SCADA) interfaces.

The RPR-1PS relay is designed to filter noise and transients from its input to prevent any false pulses at its output. Bright red and green LED indicators display the system's status at all times, thus allowing a rapid visual check of the system's performance without requiring any additional test equipment.

The RPR-1PS' input and output circuit's terminal strip is a "Euro" type connector. The "K" lead of the RPR-1PS' output is fused to prevent damage to the relay under almost any condition a user might cause such as excessive current, incorrect wiring, etc. The RPR-1PS' robust solid state switching device is rated at 800V and 750mA giving maximum protection from lightning or transient voltage damage. Its built-in transient protection for the solid state switch contacts eliminates the need for external or off-board transient suppression devices. All component parts that have power applied to them, with the exception of the input/output terminal strip, are enclosed in a polycarbonate cover for maximum protection. The mounting base plate is also made of polycarbonate and offers excellent electrical insulation between the circuit and the mounting surface.



FUNCTIONAL SUMMARY

	IN	OUT
#	1	1
TYPE	3 Wire	3 Wire
FORM	C	C

RPR-1PS



SSI ELITE

RPR-1PS PULSE ISOLATION RELAY

B-SERIES
FORMERLY THE RPR-1PS A-SERIES

SPECIFICATIONS

ELECTRICAL

Power Input:	120 VAC, 208-277 VAC. Burden: 10 mA at 120 VAC
Pulse Output:	One set of Form C dry contacts (K, Y & Z) for energy pulses. The solid state "no bounce" relay contacts are rated at 250 VAC/VDC @ 1/2 Amp. The maximum rating of the contacts is 100 VA. Factory fused at 1/2 amp. (3AG)
Contact On-State Resistance:	2.3 ohms maximum, 1.7 ohms typical
Insulation Resistance:	50 megohms typical
Operate & Release Time:	Turn-on time - 8 milliseconds typical, 20mS max Turn-off time - 1 milliseconds typical, 5mS max
Input/Output Isolation Voltage:	2500Vrms

MECHANICAL

Mounting:	Any position
Size:	3.27" wide, 5.65" high, 1.50" deep
Weight:	12 ounces

TEMPERATURE

Temperature Range:	-38° C to +85° C, -36.4° F to +158° F
Humidity:	0 to 98% non-condensing

AVAILABLE OPTIONS

Input Voltages:	24 VAC/24VDC, 125VDC - call factory for details
-----------------	---

RPR-1PS



SSI ELITE

RPR-2PS PULSE ISOLATION RELAY

C-SERIES

FORMERLY THE RPR-2PS B-SERIES

DESCRIPTION

The RPR-2PS pulse isolation relay is designed to provide two isolated solid state Form C (K, Y, & Z) contacts from a single Form C input. The RPR-2PS supplies its own sense voltage to the pulse sending unit, usually an electric meter's pulse initiator.

Typical applications include interfaces between utility metering devices and customer-owned energy control systems, demand recorder applications, and supervisory control systems (SCADA) interfaces.

The RPR-2PS relay is designed to filter noise and transients from its input to prevent any false pulses at its output. Bright red and green LED indicators display the system's status at all times thus allowing a rapid visual check of the system's performance without requiring any additional test equipment.

The RPR-2PS' input and output circuit's terminal strip is a "Euro" type connector. The "K" lead of the RPR-2PS' output is fused to prevent damage to the relay under almost any condition a user might cause such as excessive current, incorrect wiring, etc. The RPR-2PS' robust solid state switching device is rated at 800V and 750mA giving maximum protection from lightning or transient voltage damage. Its built-in transient protection for the solid state switch contacts eliminates the need for external or off-board transient suppression devices. All component parts that have power applied to them, with the exception of the input/output terminal strip, are enclosed in a polycarbonate cover for maximum protection. The mounting base plate is also made of polycarbonate and offers excellent electrical insulation between the circuit and the mounting surface.



FUNCTIONAL SUMMARY

IN	OUT
1	2
3 Wire	3 Wire
C	C

#

TYPE

FORM

RPR-2PS

SOLID STATE INSTRUMENTS A Product Family Owned by RADIAN RESEARCH

3852 Fortune Dr. • Lafayette, IN • Ph: 765-449-5500 • Fax: 765-448-4614

www.radianresearch.com



SSI ELITE

RPR-2PS PULSE ISOLATION RELAY

C-SERIES

FORMERLY THE RPR-2PS B-SERIES

SPECIFICATIONS

ELECTRICAL

Power Input:	120 VAC, 208-277 VAC. Burden: 10 mA at 120 VAC
Pulse Output:	Two sets of Form C dry contacts (K, Y & Z) for energy pulses. The solid state "no bounce" relay contacts are rated at 250 VAC/VDC @ 1/2 Amp. The maximum rating of the contacts is 100 VA. Factory fused at 1/2 amp. (3AG)
Contact On-State Resistance:	2.3 ohms maximum, 1.7 ohms typical
Insulation Resistance:	50 megohms typical
Operate & Release Time:	Turn-on time - 8 milliseconds typical, 20mS max Turn-off time - 1 milliseconds typical, 5mS max
Input/Output Isolation Voltage:	2500V

MECHANICAL

Mounting:	Any position
Size:	3.27" wide, 5.65" high, 1.50" deep
Weight:	12 ounces

TEMPERATURE

Temperature Range:	-38° C to +85° C, -36.4° F to +158° F
Humidity:	0 to 98% non-condensing

AVAILABLE OPTIONS

Input Voltages:	24 VAC/24VDC, 125VDC - call factory for details
-----------------	---

RPR-2PS



SSI ELITE

RPR-3PS PULSE ISOLATION RELAY

B-SERIES

FORMERLY THE RPR-3PS A-SERIES

DESCRIPTION

The RPR-3PS pulse isolation relay provides three isolated solid state Form C (K, Y, & Z) contacts from a single Form C input. The RPR-3PS supplies its own sense voltage to the pulse sending unit, usually an electric meter's pulse initiator.

Typical applications include demand recorder applications, interfaces between utility metering devices and customer-owned energy control systems, and supervisory control systems (SCADA) interfaces.

The RPR-3PS relay is designed to filter noise and transients from its input to prevent any false pulses at its output. Bright red and green LED indicators display the system's status at all times thus allowing a rapid visual check of the system's performance without requiring any additional test equipment.

The RPR-3PS' input and output circuit's terminal strip connector is a "Euro" type, providing excellent insulation from live electrical contacts. The "K" lead of the RPR-3PS' output is fused to prevent damage to the relay under almost any conditions a user might cause such as excessive current, incorrect wiring, etc. The RPR-3PS' robust solid state switching device is rated at 800V at 750mA giving maximum protection from lightning or transient voltage damage. Its built-in transient protection for the solid state switch contacts eliminates the need for external or off-board transient suppression devices. All component parts that have power applied to them, with the exception of the input/output terminal strip are enclosed in a polycarbonate cover for maximum protection. The mounting base plate is also made of polycarbonate and offers excellent electrical insulation between the circuit and the mounting surface.



FUNCTIONAL SUMMARY

IN	OUT
1	3
3 Wire	3 Wire
C	C

#

TYPE

FORM

RPR-3PS

SOLID STATE INSTRUMENTS A Product Family Owned by RADIAN RESEARCH

3852 Fortune Dr. • Lafayette, IN • Ph: 765-449-5500 • Fax: 765-448-4614

www.radianresearch.com



SSI ELITE

RPR-3PS PULSE ISOLATION RELAY

B-SERIES

FORMERLY THE RPR-3PS A-SERIES

SPECIFICATIONS

ELECTRICAL

Power Input:	120 VAC, 208-277 VAC. Burden: 10 mA at 120 VAC
Pulse Output:	Three sets of Form C dry contacts (K, Y & Z) for energy pulses. The solid state "no bounce" relay contacts are rated at 250 VAC/VDC @ 1/2 Amp. The maximum rating of the contacts is 100 VA. Factory fused at 1/2 amp. (3AG
Contact On-State Resistance:	2.3 ohms maximum, 1.7 ohms typical
Insulation Resistance:	50 megohms typical
Operate and Release Time:	Turn-on time - 8 mS typical, 20 mS max Turn-off time - 1 mS typical, 5 mS max
Input/Output Isolation Voltage:	2500Vrms

MECHANICAL

Mounting:	Any position
Size:	3.50" wide, 7.20" high, 1.50" deep
Weight:	12 ounces

TEMPERATURE

Temperature Range:	-38° C to +85° C, -36.4° F to +158° F
Humidity:	0 to 98% non-condensing

AVAILABLE OPTIONS

Input Voltages:	24 VAC/24VDC, 125VDC - call factory for details
-----------------	---

RPR-3PS



SSI ELITE

RPR-22PS PULSE ISOLATION RELAY

FORMERLY THE RPR-22 & IPR-1

DESCRIPTION

The RPR-22PS pulse isolation relay incorporates two independent signal channel isolation relays in one compact package. It provides two isolated solid-state Form C (K, Y, & Z) contacts from two Form A or C inputs. Each input of the RPR-22PS supplies its own sense voltage to the pulse sending unit(s), usually an electric meter's pulse initiator.



Typical applications include interfaces between utility metering devices and customer-owned energy control systems, demand recorder applications, or supervisory control systems (SCADA) interfaces. The RPR-22PS is particularly useful in applications where one channel is Kwh pulses and the second channel is Kvarh pulses.

The RPR-22PS relay is designed to filter noise and transients from its input to prevent any false pulses at its output. Bright red and green LED lamps indicate the system's status at all times thus allowing a rapid visual check of the system's performance without requiring any additional test equipment.

In addition to selecting the Input type, the output timing configuration may be selected between long or short modes. In the long mode, the output directly follows the input creating a "mirror image" of the input pulse. In the short mode, the output will close for a fixed 100mS "short" pulse. The short output mode is generally used with a Form A end-of-interval or timing pulse.

The RPR-22PS' input and output circuit's terminal strip connector is a "EURO" type, providing excellent insulation from live electrical contacts. Each K lead of the RPR-22PS' outputs is fused to prevent damage to the relay under almost any conditions a user might cause such as excessive current, incorrect wiring, etc. The RPR-22PS' robust solid-state switching device is rated at 800V at 750mA giving maximum protection from lightning or transient voltage damage. Its built-in transient protection for the solid-state switch contacts eliminates the need for external or off-board transient suppression devices. All component parts that have power applied to them, with the exception of the input/output terminal strip are enclosed in a polycarbonate cover for maximum protection. The mounting base plate is also made of polycarbonate and offers excellent electrical insulation between the circuit and the mounting surface.

RPR-22PS

FUNCTIONAL SUMMARY

	IN	OUT
#	2	2
TYPE	2 or 3 Wire	3 Wire
FORM	A or C	C

SOLID STATE INSTRUMENTS A Product Family Owned by RADIAN RESEARCH

3852 Fortune Dr. • Lafayette, IN • Ph: 765-449-5500 • Fax: 765-448-4614

www.radianresearch.com



SSI ELITE

RPR-22PS PULSE ISOLATION RELAY

FORMERLY THE RPR-22 & IPR-1

SPECIFICATIONS

ELECTRICAL

Power Input:	120, 208-277 VAC. Burden: 10 mA at 120 VAC
Pulse Input:	Two Form A or C field-selectable
Pulse Output:	Two sets of Form C dry contacts (K, Y & Z) for energy pulses. The solid-state "no bounce" relay contacts are rated at 250 VAC/VDC @ 1/2 Amp. The maximum rating of the contacts is 100 VA. Factory fused at 1/2 amp. (3AG)
Contact On-State Resistance:	2.3 ohms maximum, 1.7 ohms typical
Insulation Resistance:	50 megohms typical
Operate and Release Time:	Turn-on time - 8 mS typical, 20mS MAX Turn-off time - 1 mS typical, 5mS MAX
Input/Output Isolation Voltage:	2500Vrms

MECHANICAL

Mounting:	Any position
Size:	3.5" wide, 7.2" high, 1.5" deep
Weight:	12 ounces

TEMPERATURE

Temperature Range:	-38° C to +70° C, -36.4° F to +158° F
Humidity:	0 to 98% non-condensing

AVAILABLE OPTIONS

Input Voltages:	24 VAC/24VDC, 125VDC
-----------------	----------------------

RPR-22PS



SSI ELITE

RPR-24PS PULSE ISOLATION RELAY

FORMERLY THE RPR-24S

DESCRIPTION

The RPR-24PS pulse isolation relay provides four isolated solid state Form C (K, Y, & Z) contacts from two Form A or C inputs. Each input of the RPR-24PS supplies its own sense voltage to the pulse sending unit(s), usually an electric meter's pulse initiator.

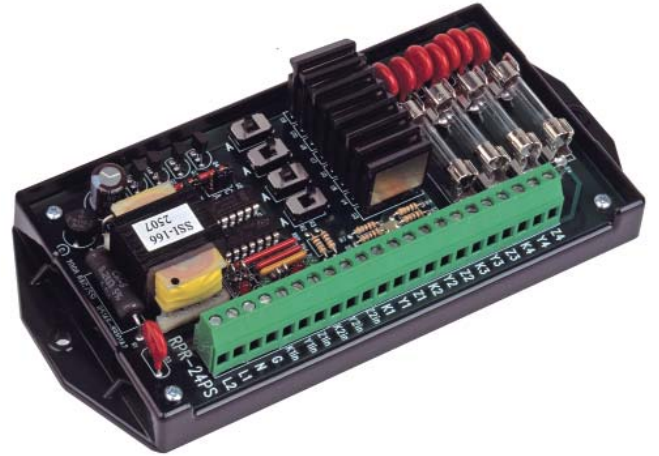

Typical applications include interfaces between utility metering devices and customer-owned energy control systems, demand recorder applications, or supervisory control systems (SCADA) interfaces.

The RPR-24PS relay is designed to filter noise and transients from its input to prevent any false pulses at its output. Bright red and green LED indicators display the system's status at all times thus allowing a rapid visual check of the system's performance without requiring any additional test equipment.

The RPR-24PS' input and output circuit's terminal strip connector is a "Euro" type, providing excellent insulation from live electrical contacts. Each "K" lead of the RPR-24PS' outputs is fused to prevent damage to the relay under almost any condition a user might cause such as excessive current, incorrect wiring, etc. The RPR-24PS' robust solid state switching device is rated at 800V at 750mA giving maximum protection from lightning or transient voltage damage. Its built-in transient protection for the solid state switch contacts eliminates the need for external or off-board transient suppression devices. All component parts that have power applied to them, with the exception of the input/output terminal strip are enclosed in a polycarbonate cover for maximum protection. The mounting base plate is also made of polycarbonate and offers excellent electrical insulation between the circuit and the mounting surface.

FUNCTIONAL SUMMARY

IN	OUT
2	4
2 or 3 Wire	3 Wire
A or C	C
Each output mappable to each input	

#

TYPE

FORM

SPECIAL FEATURES

RPR-24PS



SSI ELITE

RPR-24PS PULSE ISOLATION RELAY

FORMERLY THE RPR-24S

SPECIFICATIONS

ELECTRICAL

Power Input:	120, 208-277 VAC. Burden: 10 mA at 120 VAC
Pulse Input:	Two Form A or C field-selectable
Pulse Output:	Four sets of Form C dry contacts (K, Y & Z) for energy pulses. The solid state "no bounce" relay contacts are rated at 250 VAC/VDC @ 1/2 Amp. The maximum rating of the contacts is 100 VA. Factory fused at 1/2 amp. (3AG)
Contact On-State Resistance:	2.3 ohms maximum, 1.7 ohms typical
Insulation Resistance:	50 megohms typical
Operate and Release Time:	Turn On Time - 8 mS typical, 20mS MAX Turn Off Time - 1 mS typical, 5mS MAX
Input/Output Isolation Voltage:	2500Vrms

MECHANICAL

Mounting:	Any position
Size:	3.50" wide, 7.20" high, 1.50" deep
Weight:	12 ounces

TEMPERATURE

Temperature Range:	-38° C to +85° C, -36.4° F to +158° F
Humidity:	0 to 98% non-condensing

AVAILABLE OPTIONS

Input Voltages:	24 VAC/24VDC, 125VDC
-----------------	----------------------

RPR-24PS



SSI ELITE

RPR-33PS PULSE ISOLATION RELAY

B-SERIES
FORMERLY THE RPR-33 A-SERIES

DESCRIPTION

The RPR-33PS pulse isolation relay provides three isolated solid state Form C (K, Y, & Z) contacts from three Form A or C inputs. The RPR-33PS supplies its own sense voltage to the pulse sending units, usually electric meters' pulse initiators.

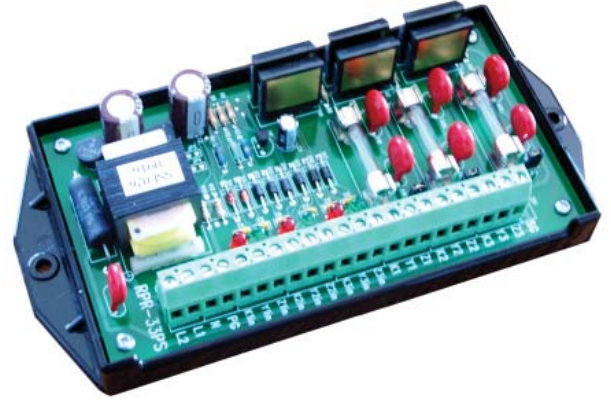

Typical applications include interfaces between utility metering devices and customer-owned energy control systems, demand recorder applications (particularly useful in applications KWh, kVarh, and EOI), or supervisory control systems (SCADA) interfaces.

The RPR-33PS relay is designed to filter noise and transients from its input to prevent any false pulses at its output. Bright red and green LED indicators display the system's status at all times thus allowing a rapid visual check of the system's performance without requiring any additional test equipment.

The RPR-33PS' input and output circuit's terminal strip connector is a "Euro" type, providing excellent insulation from live electrical contacts. The "K" lead of the RPR-33PS' output is fused to prevent damage to the relay under almost any conditions a user might cause such as excessive current, incorrect wiring, etc. The RPR-33PS' robust solid state switching device is rated at 800V at 750mA giving maximum protection from lightning or transient voltage damage. Its built-in transient protection for the solid state switch contacts eliminates the need for external or off-board transient suppression devices. All component parts that have power applied to them, with the exception of the input/output terminal strip are enclosed in a polycarbonate cover for maximum protection. The mounting base plate is also made of polycarbonate and offers excellent electrical insulation between the circuit and the mounting surface.

FUNCTIONAL SUMMARY

IN	OUT
3	3
3 Wire	3 Wire
C	C

TYPE
FORM

RPR-33PS



SSI ELITE

RPR-33PS PULSE ISOLATION RELAY

B-SERIES
FORMERLY THE RPR-33 A-SERIES

SPECIFICATIONS

ELECTRICAL

Power Input:	120, 208-277 VAC. Burden: 10 mA at 120 VAC
Pulse Input:	Three (3) Form A or Form C inputs are provided. Inputs contain +13VDC transformer-isolated power supply for wetting voltage. On each input, "Y" and "Z" terminals are "pulled-up" to +13VDC. "K" terminal is common return. +18VDC auxiliary power supply is optionally available for applications requiring a separate wetting voltage on outputs to receiving devices' inputs.
Pulse Output:	Three sets of Form C dry contacts (K, Y & Z) for energy pulses. The solid state "no bounce" relay contacts are rated at 250 VAC/VDC @ 1/2 Amp. The maximum rating of the contacts is 100 VA. Factory fused at 1/2 amp. (3AG
Contact On-State Resistance:	2.3 ohms maximum, 1.7 ohms typical
Insulation Resistance:	50 megohms typical
Operate and Release Time:	Turn-on time - 8 mS typical, 20 mS max Turn-off time - 1 mS typical, 5 mS max
Input/Output Isolation Voltage:	2500Vrms

MECHANICAL

Mounting:	Any position
Size:	3.50" wide, 7.20" high, 1.50" deep
Weight:	12 ounces

TEMPERATURE

Temperature Range:	-38° C to +85° C, -36.4° F to +158° F
Humidity:	0 to 98% non-condensing

AVAILABLE OPTIONS

Input Voltages:	24 VAC/24VDC, 125VDC
-----------------	----------------------

RPR-33PS



SSI ELITE

RPR-903PS PULSE ISOLATION RELAY

FORMERLY THE RPR-903

DESCRIPTIONS

The RPR-903PS pulse isolation relay provides three isolated solid state Form C (K, Y, & Z) contacts from a field-selectable Form A or C inputs. The RPR-903PS' input supplies its own sense voltage to the pulse sending unit(s), usually an electric meter's pulse initiator. The RPR-903PS has two fixed Form C outputs. In addition, the third output features two field-selectable modes, Normal mode or Pulse Doubling mode. In the Pulse Doubling mode the output provides a true Form C to Form A pulse value conversion.

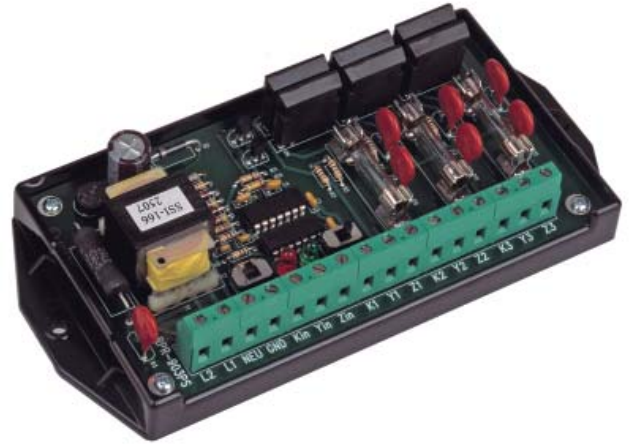

Typical applications include interfaces between utility metering devices and customer-owned energy control systems, demand recorder applications, or supervisory control systems (SCADA) interfaces.

The RPR-903PS relay is designed to filter noise and transients from its input to prevent any false pulses at its output. Bright red and green LED Indicators Display the system's status at all times thus allowing a rapid visual check of the system's performance without requiring any additional test equipment.

The RPR-903PS' input and output circuit's terminal strip connector is a "Euro" type, providing excellent insulation from live electrical contacts. Each "K" lead of the RPR-903PS' outputs is fused to prevent damage to the relay under almost any condition a user might cause such as excessive current, incorrect wiring, etc. The RPR-903PS' robust solid state switching device is rated at 800V at 750mA giving maximum protection from lightning or transient voltage damage. Its built-in transient protection for the solid state switch contacts eliminates the need for external or off-board transient suppression devices. All component parts that have power applied to them, with the exception of the input/output terminal strip are enclosed in a polycarbonate cover for maximum protection. The mounting base plate is also made of polycarbonate and offers excellent electrical insulation between the circuit and the mounting surface.

FUNCTIONAL SUMMARY

	IN	OUT
#	1	3
TYPE	2 or 3 Wire	(2) 3 Wire, (1) 2 or 3 Wire
FORM	A or C	C, A or C

RPR-903PS



SSI ELITE

RPR-903PS PULSE ISOLATION RELAY

FORMERLY THE RPR-903

SPECIFICATIONS

ELECTRICAL

Power Input:	120, 208-277 VAC. Burden: 10 mA at 120 VAC
Pulse Input:	Form A or C field-selectable +13VDC wetting voltage supplied to meter.
Pulse Output:	Three sets of Form C dry contacts (K, Y & Z) for energy pulses, two fixed and one field-selectable Form A or C. The solid state "no bounce" relay contacts are rated at 250 VAC/VDC @ 1/2 Amp. The maximum rating of the contacts is 100 VA. Factory fused at 1/2 amp. (3AG)
Contact On-State Resistance:	2.3 ohms maximum, 1.7 ohms typical
Insulation Resistance:	50 megohms typical
Operate and Release Time:	Turn-on time - 8 mS typical, 20mS MAX Turn-off time - 1 mS typical, 5mS MAX
Input/Output Isolation Voltage:	2500Vrms

MECHANICAL

Mounting:	Any position
Size:	3.50" wide, 7.20" high, 1.50" deep
Weight:	12 ounces

TEMPERATURE

Temperature Range:	-38° C to +85° C, -36.4° F to +158° F
Humidity:	0 to 98% non-condensing

AVAILABLE OPTIONS

Input Voltages:	24 VAC/24VDC, 125VDC
-----------------	----------------------

RPR-903PS



SSI ELITE

PIR-1PS+ PULSE ISOLATION RELAY

FORMERLY THE PIR-1

DESCRIPTION

The PIR-1PS+ repeating pulse relay is designed to provide one isolated solidstate Form A (K & Y) contacts from a single Form A input. The PIR-1PS+ supplies its own isolated +13VDC wetting voltage to the pulse sending unit, usually an electric meter's pulse initiator. Typical applications include interfaces between utility metering devices and customer owned energy control systems, demand recorder applications, and supervisory control systems (SCADA) interfaces.



FUNCTIONAL SUMMARY

IN	OUT
1	1
2 Wire	2 Wire
A	A

TYPE
FORM

PIR-1PS+

The PIR-1PS+' dual-dielectric barrier design uses two optical isolation barriers insuring maximum protection from electric disruptions between the input and output. The microcontroller-based PIR-1PS+ has two operating modes: normal and fixed. In the normal mode, output pulses are the same time duration as the input pulse duration. In fixed mode, the output time is fixed regardless of the input pulse length. In both modes the PIR-1PS+ filters noise and transients at its input to prevent any false pulses at its output. If the incoming pulse is less than the specified time – 2,5, 10 or 20 milliseconds - the PIR-1PS+ assumes that the incoming pulse is noise and disregards it. Thus, any valid pulse rate of 25 pulses per second (50-on/50-off form factor) or less is accepted while static and induced noise is rejected. If used in a very noisy environment, the pulse acceptance window can be lengthened or shortened.

The PIR-1PS+' output closure time (in the fixed mode) is selectable for 100, 300, 500 or 1000 milliseconds, regardless of the input pulse's duration. The output duration time may be easily selected by moving jumper locations. In the event that the input pulse rate exceeds the output time such that input pulses are arriving from the meter faster than the output can handle, the microcontroller stores these pulses and outputs them as soon as possible, so that no pulses are lost. Bright red and green LED indicators display the system's status at all times thus allowing a rapid visual check of the system's performance without requiring any additional test equipment. The input and output terminal strip connector is a "Euro" type providing excellent electrical insulation. The "K" lead of the PIR-1PS+' outputs are fused to prevent damage to the relay under almost any condition a user might cause such as excessive current, incorrect wiring, etc. The PIR-1PS+' robust solid state switching device is rated at 800V and 750mA giving maximum protection from lightning or transient voltage damage. Its built-in transient protection for the solid-state switch contacts eliminates the need for external or off-board transient suppression devices. All component parts that have power applied to them, with the exception of the input/output terminal strip are enclosed in a polycarbonate cover for maximum protection. The mounting base plate is also made of polycarbonate and offers excellent electrical insulation between the circuit and the PIR-1PS+ mounting surface.



SSI ELITE

PIR-1PS+ PULSE ISOLATION RELAY

FORMERLY THE PIR-1

SPECIFICATIONS

ELECTRICAL

Power Input:	120, 208-277 VAC. Burden: 10 mA at 120 VAC
Pulse Output:	One Form A dry contacts (K & Y) for energy pulses. The solid state "no bounce" relay contacts are rated at 250 VAC/VDC @ 1/2 Amp. The maximum rating of the contacts is 100 VA. Factory fused at 1/2 amp. (3AG)
Contact On-State Resistance:	2.3 ohms maximum, 1.7 ohms typical
Insulation Resistance:	50 megohms typical
Operate and Release Time:	Turn-on time - 8 mS typical, 20mS MAX Turn-off time - 1 mS typical, 5mS MAX
Input/Output Isolation Voltage:	2500Vrms

MECHANICAL

Mounting:	Any position
Size:	3.27" wide, 5.65" high, 1.50" deep
Weight:	12 ounces

TEMPERATURE

Temperature Range:	-38° C to +85° C, -36.4° F to +158° F
Humidity:	0 to 98% non-condensing

AVAILABLE OPTIONS

Input Voltages:	24 VAC/24VDC, 125VDC
-----------------	----------------------

PIR-1PS+



SSI ELITE

PIR-2PS+ PULSE ISOLATION RELAY

FORMERLY THE PIR-2

DESCRIPTION

The PIR-2PS+ pulse isolation relay is designed to provide two isolated solid state Form A (K & Y) contacts from a single Form A input. The PIR-2PS+ supplies its own isolated +13VDC wetting voltage to the pulse sending unit, usually an electric meter's pulse initiator. Typical applications include interfaces between utility metering devices and customer-owned energy control systems, demand recorder applications, and supervisory control systems (SCADA) interfaces.

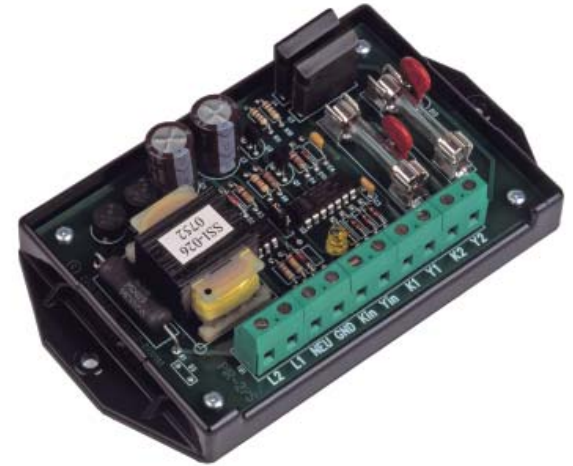

FUNCTIONAL SUMMARY

IN	OUT
1	2
2 Wire	2 Wire
A	A

TYPE
FORM

PIR-2PS+

The PIR-2PS+' dual-dielectric barrier design uses two optical isolation barriers insuring maximum protection from electric disruptions between the input and output. The PIR-2PS+ is designed to filter noise and transients at its input to prevent any false pulses at its output. If the incoming pulse is less than 20 milliseconds in length, the PIR-2PS+ assumes that the incoming pulse is noise and it is disregarding. Thus, any valid pulse rate of 25 pulses per second (50-on/50-off form factor) or less is accepted while static and induced noise is rejected. If used in a very noisy environment, the pulse acceptance window can be lengthened or shortened.

The PIR-2PS+'s output closure time (in the fixed mode) is selectable for 100, 300, 500 or 1000 milliseconds, regardless of the input pulse's duration. The output duration time may be easily selected by moving jumper locations. In the event that the input pulse rate exceeds the output time such that input pulses are arriving from the meter faster than the output can handle, the microcontroller stores these pulses and outputs them as soon as possible, so that no pulses are lost.

Bright red and green LED indicators display the system's status at all times thus allowing a rapid visual check of the system's performance without requiring any additional test equipment. The input and output terminal strip connector is a "Euro" type providing excellent electrical insulation. The "K" lead of the PIR-2PS+'s outputs are fused to prevent damage to the relay under almost any condition a user might cause such as excessive current, incorrect wiring, etc. The PIR-2PS+'s robust solid state switching device is rated at 800V and 750mA giving maximum protection from lightning or transient voltage damage. Its built-in transient protection for the solid state switch contacts eliminates the need for external or off-board transient suppression devices. All component parts that have power applied to them, with the exception of the input/output terminal strip are enclosed in a polycarbonate cover for maximum protection. The mounting base plate is also made of polycarbonate and offers excellent electrical insulation between the circuit and the mounting surface.



SSI ELITE

PIR-2PS+ PULSE ISOLATION RELAY

FORMERLY THE PIR-2

SPECIFICATIONS

ELECTRICAL

Power Input:	120, 208-277 VAC. Burden: 10 mA at 120 VAC
Pulse Output:	Two Form A dry contacts (K & Y) for energy pulses. The solid state "no bounce" relay contacts are rated at 250 VAC/VDC @ 1/2 Amp. The maximum rating of the contacts is 100 VA. Factory fused at 1/2 amp. (3AG)
Contact On-State Resistance:	2.3 ohms maximum, 1.7 ohms typical
Insulation Resistance:	50 megohms typical
Operate and Release Time:	Turn-on time - 8 mS typical, 20mS MAX Turn-off time - 1 mS typical, 5mS MAX
Input/Output Isolation Voltage:	2500Vrms

MECHANICAL

Mounting:	Any position
Size:	3.27" wide, 5.65" high, 1.50" deep
Weight:	12 ounces

TEMPERATURE

Temperature Range:	-38° C to +85° C, -36.4° F to +158° F
Humidity:	0 to 98% non-condensing

AVAILABLE OPTIONS

Input Voltages:	24 VAC/24VDC, 125VDC
Enclosure:	NEMA 3R or 4X

PIR-2PS+



SSI ELITE

PIR-3PS+ PULSE ISOLATION RELAY

FORMERLY THE PIR-3

DESCRIPTION

The PIR-3PS+ pulse isolation relay is designed to provide two isolated solid state Form A (K & Y) contacts from a single Form A input. The PIR-3PS+ supplies its own isolated +13VDC wetting voltage to the pulse sending unit, usually an electric meter's pulse initiator. Typical applications include interfaces between utility metering devices and customer-owned energy control systems, demand recorder applications, and supervisory control systems (SCADA) interfaces.



FUNCTIONAL SUMMARY

IN	OUT
1	3
2 Wire	2 Wire
A	A

TYPE
FORM

PIR-3PS+

The PIR-3PS+' dual-dielectric barrier design uses two optical isolation barriers insuring maximum protection from electric disruptions between the input and output. The PIR-3PS+ is designed to filter noise and transients at its input to prevent any false pulses at its output. If the incoming pulse is less than 20 milliseconds in length, the PIR-3PS+ assumes that the incoming pulse is noise and it is disregarding. Thus, any valid pulse rate of 25 pulses per second (50-on/50-off form factor) or less is accepted while static and induced noise is rejected. If used in a very noisy environment, the pulse acceptance window can be lengthened or shortened.

The PIR-3PS+' output closure time (in the fixed mode) is selectable for 100, 300, 500 or 1000 milliseconds, regardless of the input pulse's duration. The output duration time may be easily selected by moving jumper locations. In the event that the input pulse rate exceeds the output time such that input pulses are arriving from the meter faster than the output can handle, the microcontroller stores these pulses and outputs them as soon as possible, so that no pulses are lost.

Bright red and green LED indicators display the system's status at all times thus allowing a rapid visual check of the system's performance without requiring any additional test equipment. The input and output terminal strip connector is a "Euro" type providing excellent electrical insulation. The "K" lead of the PIR-3PS+' outputs are fused to prevent damage to the relay under almost any condition a user might cause such as excessive current, incorrect wiring, etc. The PIR-3PS+' robust solid state switching device is rated at 800V and 750mA giving maximum protection from lightning or transient voltage damage. Its built-in transient protection for the solid state switch contacts eliminates the need for external or off-board transient suppression devices. All component parts that have power applied to them, with the exception of the input/output terminal strip are enclosed in a polycarbonate cover for maximum protection. The mounting base plate is also made of polycarbonate and offers excellent electrical insulation between the circuit and the mounting surface.



SSI ELITE

PIR-3PS+ PULSE ISOLATION RELAY

FORMERLY THE PIR-3

SPECIFICATIONS

ELECTRICAL

Power Input:	120, 208-277 VAC. Burden: 10 mA at 120 VAC
Pulse Output:	Two Form A dry contacts (K & Y) for energy pulses. The solid state "no bounce" relay contacts are rated at 250 VAC/VDC @ 1/2 Amp. The maximum rating of the contacts is 100 VA. Factory fused at 1/2 amp. (3AG)
Contact On-State Resistance:	2.3 ohms maximum, 1.7 ohms typical
Insulation Resistance:	50 megohms typical
Operate and Release Time:	Turn-on time - 8 mS typical, 20mS MAX Turn-off time - 1 mS typical, 5mS MAX
Input/Output Isolation Voltage:	2500Vrms

MECHANICAL

Mounting:	Any position
Size:	3.5" wide, 7.2" high, 1.50" deep
Weight:	12 ounces

TEMPERATURE

Temperature Range:	-38° C to +85° C, -36.4° F to +158° F
Humidity:	0 to 98% non-condensing

AVAILABLE OPTIONS

Input Voltages:	24 VAC/24VDC, 125VDC
Enclosure:	NEMA 3R or 4X

PIR-3PS+



PULSE ISOLATION RELAY - SOLID STATE

PCR-3PS PULSE CONVERSION RELAY

DESCRIPTIONS

The PCR-3PS Universal Pulse Conversion Relay is designed to provide TRUE 3-Wire to 2-Wire OR 2-Wire to 3-Wire conversion in a single microcontroller-based relay. The conversion mode is field-selectable and does not require the use of any special tools or equipment. In addition, the PCR-3PS has a normal "Straight-through" mode that allows the PCR-3PS to act as a non-converting normal isolation relay. In this mode, a Form A (2-wire) input will result in a Form A output. A Form C (3-wire) input will result in a Form C output.



FUNCTIONAL SUMMARY

	IN	OUT
#	1	1
TYPE	2 or 3 Wire	2 or 3 Wire
FORM	A or C	A or C

PCR-3PS

In the 3-Wire to 2-Wire Mode, the PCR-3PS provides "true" conversion of each change of state of the 3-wire KYZ input circuit into a fixed 100 millisecond long 2-wire isolated output contact closure. The PCR-3PS checks for the correct sequence of the input pulses before allowing an output pulse to occur. A K to Y input contact closure followed by a K to Z input contact closure will result in an output closure. A K to Y input contact closure followed by an interruption and then another K to Y contact closure will only result in an output closure for the first input closure. The second and all future K to Y input closures will be ignored until a valid K to Z input closure occurs. An input closure must be at least 20mS long to be recognized as a valid input pulse.

In the 2-Wire to 3-Wire Mode, the PCR-3PS provides "true" conversion of each change of state of the K-Y input 2-wire circuit into alternating changes of state of the 3-wire Form C isolated output contact closure. The PCR-3PS checks for the correct sequence of the input pulses before allowing an output pulse to occur. A K to Y input contact closure of at least 20mS will result in an output closure. The K to Y input contact closure must be open or interrupted for at least 20mS for the input to be reset and prepared for the next K to Y contact closure. An input closure less than 20mS is ignored.

Typical applications include supervisory control (SCADA) systems, energy management systems and energy demand/KWH counters. Two sets of bright Red and Green LEDs lamps show the status of the input and output at all times, thus allowing a rapid visual check-out of the systems performance without the use of any additional tools or test instruments.

The PCR-3PS's input and output circuit's terminal strip is "EURO" type connector strip. When the stripped wire has been correctly installed in the terminals' "slot" no conductive parts are exposed on the surface of the terminal strip, thus allowing the user maximum protection from accidental electrical shock. The K lead of the PCR-3PS's output is fused to prevent damage to the relay under almost any conditions a user might subject the system to such as excessive current, voltages, and incorrect wiring, etc. The PCR-3PS has built-in transient protection for the solid-state relay's contacts that eliminates the need for external or off-the-board transient suppressors.

All component parts that have power applied to them, with the exception of the input/output terminal strip, are enclosed in a polycarbonate cover for maximum user protection. The mounting base plate is also made of polycarbonate and offers excellent electrical insulation. The PCR-3PS is designed to mount in an electrical enclosure appropriate for the application and operating environment.



PULSE ISOLATION RELAY - SOLID STATE

PCR-3PS PULSE CONVERSION RELAY

SPECIFICATIONS

ELECTRICAL

Power Input:	120, 208-277 VAC. Burden: 10 mA at 120 VAC
Pulse Output:	One set of dry Form C contacts (K, Y, & Z) for energy pulses. The contacts are solid state relays rated at 250 VAC/VDC @ 500mA. The maximum rating of the contacts is 100 VA. Factory fused at 1/4 amp @ 250VAC (3AG).
Contact On-State Resistance:	2.3 ohms max, 1.7 ohms typical
Insulation Resistance	50 megohms typical
Operate and Release Time:	Turn on-time - 8 mS typical; 20 mS MAX Turn off-time - 1 mS typical; 5 mS MAX
Input/Output Isolation Voltage:	2500Vrms

MECHANICAL

Mounting:	Any position
Size:	3.27" wide, 5.65" high, 1.50" deep
Weight:	9 ounces

TEMPERATURE

Temperature Range:	-38° C to +70° C, -36.4° F to +158° F
Humidity:	0 to 98% non-condensing

AVAILABLE OPTIONS

Input Voltages:	Contact Factory
-----------------	-----------------

PCR-3PS



SELF-CONTAINED RELAYS (OUTDOOR)

CIR-1PS+ CUSTOMER INTERFACE RELAY

FORMERLY THE CIR-1A and CIR-1PS

DESCRIPTION

The CIR-1PS+ Customer Interface Relay provides a single isolated solid-state dry Form A (K & Y) or Form C (K, Y, & Z) contact from a single Form A or C input. The typical application is the utility's interface between the KWH meter and a customer-owned energy control system. The CIR-1PS+ includes everything necessary to provide a customer with energy pulses in one compact ready-to-use weather-resistant NEMA 4X enclosure.

The CIR-1PS+ is internally divided into two compartments. Once installed, the upper compartment is normally locked and only accessible to utility metering personnel. It contains all of the electronics along with fusing that is coordinated with the fusing contained within the customer compartment. The lower compartment, (customer compartment) contains a terminal strip, fusing, status indication LEDs, and a switch that allows the customer to choose either a 2-Wire or 3-Wire output. With the switch in the two-wire mode, each relay contact closure is approximately 100 milliseconds long and occurs each time the 3-Wire input changes state thereby doubling the pulse value automatically for Form A applications. The red LED lights each time there is a contact closure.

With the switch in the 3-Wire mode, the terminal strip contacts "K" and "Y", and "K" and "Z" will directly follow the input's status. In this mode, both the red and green LEDs are lit alternately depending upon input's status. The use of LEDs in the customer's compartment allows a rapid visual check of the system's performance without requiring any additional test equipment. Because of the redundant, coordinated fusing in both the utilities and customer's compartments, the meter shop service coordinator can usually determine the location of the service problem as to either utility or customer responsibility by the simple question "are the LEDs flashing". The double "K" lead coordinated fusing of the CIR-1PS+'s output will prevent damage to the relay under almost any condition a user might cause such as that caused by excessive current, incorrect wiring, etc. The CIR-1PS+'s robust solid state switching device is rated at 800V and 750mA giving maximum protection from lightning or transient voltage damage. The CIR-1PS+ has built-in transient protection for the solid state switching devices that eliminates the need for external or off-the-board transient suppressors.



FUNCTIONAL SUMMARY

	IN	OUT
#	1	1
TYPE	3 Wire	2 or 3 Wire
FORM	C	*A or C
* Switchable		

CIR-1PS+

SOLID STATE INSTRUMENTS A Product Family Owned by RADIAN RESEARCH

3852 Fortune Dr. • Lafayette, IN • Ph: 765-449-5500 • Fax: 765-448-4614

www.radianresearch.com



SELF-CONTAINED RELAYS (OUTDOOR)

CIR-1PS+ CUSTOMER INTERFACE RELAY

FORMERLY THE CIR-1A and CIR-1PS

SPECIFICATIONS

ELECTRICAL

Power Input:	120, 208-277 VAC. Burden: 10 mA at 120 VAC
Pulse Input:	One Form C (3-wire) input with +13VDC wetting voltage on the K terminal
Pulse Output:	One field-selectable Dry Form A or Form C contact (K & Y or K, Y, & Z) selected by a user-changeable switch located in the customer's compartment, for energy pulses. The contacts are solid state "no bounce" relays rated at 250VACVDC at 1/2 Amp. The maximum rating of the contacts is 100 VA. Factory fused at 1/2 amp. (3AG)
Contact On-State Resistance:	2.3 ohms maximum, 1.7 ohms typical
Insulation Resistance:	50 megohms typical
Operate and Release Time:	Turn-on time - 8 mS typical, 20 mS MAX Turn-off time - .15 mS typical, 5 mS MAX
Input/Output Isolation Voltage:	2500Vrms

MECHANICAL

Mounting:	Any position
Size:	8.0" wide, 10.0" high, 4.50" deep
Weight:	9 pounds
Type/Material:	NEMA 4X Fiberglass Case

TEMPERATURE

Temperature Range:	-38° C to +70° C, -36.4° F to +158° F
Humidity:	0 to 98% non-condensing

AVAILABLE OPTIONS

Input Voltages:	+15 to +48VDC, +125VDC
-----------------	------------------------

CIR-1PS+



SELF-CONTAINED RELAYS (OUTDOOR)

CIR-2PS+ CUSTOMER INTERFACE RELAY

FORMERLY THE CIR-2A and CIR-2PS

DESCRIPTION

The CIR-2PS+ Customer Interface Relay provides two isolated solid-state dry contacts from a single Form A or C input. One set of contacts may be configured as either a Form A (K & Y) or a Form C (K, Y, & Z) contact. The second set of contacts is a fixed 3-Wire Form C output typically used for a pulse recorder or other utility instrumentation. The typical application is the utilities' interface between the KWH meter and a customer-owned energy control system. The CIR-2PS+ includes everything necessary to provide a customer with energy pulses in one compact ready-to-use weather-resistant NEMA 4X enclosure.



FUNCTIONAL SUMMARY

	IN	OUT
#	1	2
TYPE	3 Wire	(1) 3 Wire, (1) 2 Wire or 3 Wire
FORM	C	*A or C
	* Switchable	

The CIR-2PS+ is internally divided into two compartments. Once installed, the upper compartment is normally locked and only accessible to utility metering personnel. It contains all of the electronics along with fusing that is coordinated with the fuse contained within the customer compartment. The lower compartment (customer compartment) contains a terminal strip, fusing, output status LEDs, and a switch allowing the customer to choose either a 2-wire or 3-wire output. With the switch in the two-wire mode, each relay contact closure is approximately 100 milliseconds long and occurs each time the 3-wire input changes state thereby doubling the pulse value automatically for Form A applications. The red LED will only light each time there is a contact closure.

With the switch in the 3-wire mode, the relay contacts "K" and "Y", and "K" and "Z" directly follow the input's status. In this mode, both the red and green LEDs light alternately depending upon input's status. The use of LEDs in the customer's compartment allows a rapid visual check of the system's performance without requiring any additional test equipment. Because of the redundant, coordinated fusing in both the utility's and customer's compartments, the meter shop service coordinator can usually determine the location of the service problem as to either utility or customer responsibility by the simple question "are the LEDs flashing". The double "K" lead coordinated fusing of the CIR-2PS+'s output will prevent damage to the relay under almost any condition a user might cause such as that caused by excessive current, incorrect wiring, etc. The CIR-2PS+' robust solid state switching device is rated at 800V and 750mA giving maximum protection from lightning or transient voltage damage. The CIR-2PS+ has built-in transient protection for the solid state switching devices that eliminates the need for external or off-the-board transient suppressors.

CIR-2PS+



SELF-CONTAINED RELAYS (OUTDOOR)

CIR-2PS+ CUSTOMER INTERFACE RELAY

FORMERLY THE CIR-2A and CIR-2PS

SPECIFICATIONS

ELECTRICAL

Power Input:	120, 208-277 VAC. Burden: 10 mA at 120 VAC
Pulse Input:	One Form C (3-Wire) input with +13VDC wetting voltage on the K terminal.
Pulse Output:	Two sets of dry contact solid state outputs. <u>Output 1:</u> One field-selectable set of Form A or Form C contacts (K & Y or K, Y, & Z) selected by a user-changeable switch, located in the customer's compartment. <u>Output 2:</u> one fixed set of Form C contacts located in the utility compartment. The contacts are solid state "no bounce" relays rated at 250VACVDC at 1/2 Amp. The maximum rating of the contacts is 100 VA. Factory fused at 1/2 amp. (3AG)
Contact On-State Resistance:	2.3 ohms maximum, 1.7 ohms typical
Insulation Resistance:	50 megohms typical
Operate and Release Time:	Turn-on time - 8 mS typical, 20mS MAX Turn-off time - .15 mS typical, 5mS MAX
Input/Output Isolation Voltage:	2500Vrms

MECHANICAL

Mounting:	Any position
Size:	9.0" wide, 11.0" high, 4.50" deep
Weight:	9 pounds
Type/Material:	NEMA 4X Fiberglass case

TEMPERATURE

Temperature Range:	-38° C to +85° C, -36.4° F to +158° F
Humidity:	0 to 98% non-condensing

AVAILABLE OPTIONS

Input Voltages:	+15 to +48VDC, +125VDC
-----------------	------------------------

CIR-2PS+



SELF-CONTAINED RELAYS (OUTDOOR)

CIR-3PS+ CUSTOMER INTERFACE RELAY

FORMERLY THE CIR-3A and CIR-3PS

DESCRIPTION

The CIR-3PS+ Customer Interface Relay provides two isolated solid-state dry contacts from a single Form A or C input, and a single end-of-interval (EOI) contact. One set of contacts may be configured as either a Form A (K & Y) or a Form C (K, Y, & Z) contact. The second set of contacts is a fixed 3-Wire Form C output typically used for a pulse recorder or other utility instrumentation. The EOI output is a dry Form A contact. The typical application is the utilities' interface between the KWH meter & recorder and a customer-owned energy control system. The CIR-3PS+ includes everything necessary to provide a customer with energy pulses in one compact ready-to-use weather-resistant NEMA 4X enclosure.



FUNCTIONAL SUMMARY

	IN	OUT
#	2	3
TYPE	(1) 3 Wire and (1) 2 Wire	(1) 3 Wire, (1) 2 Wire, or (1) 2 or 3 Wire*
FORM	A or C	C, A, A or C*
* Switchable		

CIR-3PS+

The CIR-3PS+ is internally divided into two compartments. Once installed, the upper compartment is normally locked and only accessible to utility metering personnel. It contains all of the electronics along with fusing that is coordinated with the fuse contained within the customer compartment. The lower compartment (customer compartment) contains a terminal strip, fusing, output status LEDs, and two switches which allow the customer to choose either a 2-Wire or 3-Wire output, and either a short (fixed) or "long" (actual) duration for the end-of-interval timing contact closure. The fixed duration period is selectable at 100, 300, 500 or 1000 milliseconds.

For the customer's KYZ output, with the switch in the two-wire mode, each relay contact closure is approximately 100 milliseconds long and occurs each time the 3-wire input changes state thereby doubling the pulse value automatically for Form A applications. The red LED will only light each time there is a contact closure. With the switch in the 3-wire mode, the relay contacts "K" and "Y", and "K and "Z" directly follow the input's status. In this mode, both the red and green LEDs light alternately depending upon input's status. A yellow LED in the customer's compartment shows the status of the EOI circuit.

The use of LEDs in the customer's compartment allows a rapid visual check of the system's performance without requiring any additional test equipment. Because of the redundant, coordinated fusing in both the utilities and customer's compartments, the meter shop service coordinator can usually determine the location of the service problem as to either utility or customer responsibility by the simple question "are the LEDs flashing". The double "K" lead coordinated fusing of the CIR-3PS+'s output will prevent damage to the relay under almost any condition a user might cause such as that caused by excessive current, incorrect wiring, etc. The CIR-3PS+'s robust solid state switching device is rated at 800V and 750mA giving maximum protection from lightning or transient voltage damage. The CIR-3PS+ has built-in transient protection for the solid-state switching devices that eliminates the need for external or off-the-board transient suppressors.



SELF-CONTAINED RELAYS (OUTDOOR)

CIR-3PS+ CUSTOMER INTERFACE RELAY

FORMERLY THE CIR-3A and CIR-3PS

SPECIFICATIONS

ELECTRICAL

Power Input:	120, 208-277 VAC. Burden: 10 mA at 120 VAC
Pulse Inputs:	One Form C (3-Wire) input with +13VDC wetting voltage on the "K" terminal for energy pulses. One Form A (2-Wire) input with +13VDC wetting voltage on the "K" terminal for EOI signal
Pulse Outputs:	Three sets of dry contact solid state outputs. <u>Output 1:</u> one field-selectable set of Form A or Form C dry contacts (K & Y or K, Y, & Z) selected by a user-changeable switch, located in the customer's compartment for energy pulses. <u>Output 2:</u> one fixed set of Form C dry contacts located in the utility compartment for energy pulses. <u>Output 3:</u> one fixed set of Form A dry contacts located in the customer compartment for EOI timing pulse. The contacts are solid state "no bounce" relays rated at 250VACVDC at 1/2 Amp. The maximum rating of the contacts is 100 VA. Factory fused at 1/2 amp. (3AG)
Contact On-State Resistance:	2.3 ohms maximum, 1.7 ohms typical
Insulation Resistance:	50 megohms typical
Operate and Release Time:	Turn-on time - 8 mS typical, 20mS MAX Turn-off time - .15 mS typical, 5mS MAX
Input/Output Isolation Voltage:	2500Vrms

MECHANICAL

Mounting:	Any position
Size:	9.0" wide, 11.0" high, 4.50" deep
Weight:	9 pounds
Type/Material:	NEMA 4X Fiberglass Case

TEMPERATURE

Temperature Range:	-38° C to +85° C, -36.4° F to +158° F
Humidity:	0 to 98% non-condensing

AVAILABLE OPTIONS

Input Voltages:	+15 to +48VDC, +125VDC
-----------------	------------------------

CIR-3PS+



SELF-CONTAINED RELAYS (OUTDOOR) - SOLID STATE CIR-13PS CUSTOMER INTERFACE RELAY

FORMERLY THE CIR-13S

DESCRIPTION

The CIR-13PS Customer Interface Relay provides three isolated solid state dry Form C contacts from a single Form A or C input. Each set of output contacts may be used as either a Form A (K & Y) or a Form C (K, Y, & Z) contact. The typical application is the utility's interface between the KWH meter and a customer-owned energy control system. The CIR-13PS includes everything necessary to provide a customer with energy pulses in one compact ready-to-use weather-resistant enclosure.



The CIR-13PS is internally divided into two compartments. Once installed, the upper compartment is normally locked and only accessible to utility metering personnel. It contains all of the electronics along with fusing that is coordinated with the fuse contained within the customer compartment. The lower compartment (customer compartment) contains a terminal strip, fusing, and output status LEDs. Using a jumper selector, the outputs can be configured in the "Long" or "Short" pulse output mode. With the selector in the long mode, the relays' contact closure is the same duration as the input's closure duration. In the short mode, the output is closed for a approximately 100 milliseconds regardless of the input's closure duration. Red and green LEDs located in the customer's compartment light alternately depending upon input's status. The use of LEDs allows a rapid visual check of the system's performance by inexperienced personnel without requiring any additional test equipment. Because of the redundant, coordinated fusing in both the utility's and customer's compartments, the meter shop service coordinator can usually determine the location of the service problem as to either utility or customer responsibility by the simple question "are the LEDs flashing". The double "K" lead coordinated fusing of the CIR-13PS's output will prevent damage to the relay under almost any condition a user might cause such as that caused by excessive current, incorrect wiring, etc. The CIR-13PS' robust solid state switching device is rated at 800V and 750mA giving maximum protection from lightning or transient voltage damage. The CIR-13PS has built-in transient protection for the solid state switching devices that eliminates the need for external or off-the-board transient suppressors.

FUNCTIONAL SUMMARY

	IN	OUT
#	1	3
TYPE	2 or 3 Wire	3 Wire
FORM	A or C	C

CIR-13PS



SELF-CONTAINED RELAYS (OUTDOOR) - SOLID STATE

CIR-13PS CUSTOMER INTERFACE RELAY

FORMERLY THE CIR-13S

SPECIFICATIONS

ELECTRICAL

Power Input:	120, 208-277 VAC. Burden: 10 mA at 120 VAC
Pulse Input:	One Form A (2-Wire) or C (3-Wire) input with +13VDC wetting voltage on the Y and Z terminals
Pulse Output:	Three sets of dry contact solid state outputs. <u>Output 1</u> : one set of Form C contacts (K, Y, & Z) located in the customer's compartment. <u>Output 2 & 3</u> : two sets of Form C contacts located in the utility compartment. The contacts are solid state "no bounce" relays rated at 250 VACVDC at 1/2 Amp. The maximum rating of the contacts is 100 VA. Factory fused at 1/4 amp. (3AG)
Contact On-State Resistance:	2.3 ohms maximum, 1.7 ohms typical
Insulation Resistance:	50 megohms typical
Operate and Release Time:	Turn on-time - 8 mS typical; 20 mS MAX Turn off-time - 1 mS typical; 5 mS MAX
Input/Output Isolation Voltage:	2500Vrms

MECHANICAL

Mounting:	Any position
Size:	9.0" wide, 11.0" high, 4.50" deep
Weight:	9 pounds
Type/Material:	NEMA 4X Fiberglass Case

TEMPERATURE

Temperature Range:	-38° C to +70° C, -36.4° F to +158° F
Humidity:	0 to 98% non-condensing

AVAILABLE OPTIONS

Input Voltages:	24 VAC/24VDC, 125VDC
-----------------	----------------------

CIR-13PS



SELF-CONTAINED RELAYS (OUTDOOR) - SOLID STATE

CIR-22PS CUSTOMER INTERFACE RELAY

FORMERLY THE CIR-22S & CIR-22A/B

DESCRIPTION

The CIR-22PS Customer Interface Relay provides two isolated solid state dry Form C contacts from two Form A or C inputs. Each set of output contacts may be used as either a Form A (K & Y) or a Form C (K, Y, & Z) contact. The typical application is the utility's interface between the KWH meter and a customer-owned energy control system where two types of pulses are used. For example, one channel might be for watt-hour pulses and the second channel for var-hour pulses. The CIR-22 provides two independent isolation relay channels in one ready-to-use weather-resistant package.

The CIR-22PS is internally divided into two compartments. Once installed, the upper compartment is normally locked and only accessible to utility metering personnel. It contains all of the electronics along with fusing that is coordinated with the fuse contained within the customer compartment. The lower compartment (customer compartment) contains a terminal strip, fusing, and output status LEDs. Using jumper selector, the inputs can be configured as 2-Wire or 3-Wire inputs and the outputs can be configured in the "Long" or "Short" pulse output mode. With the output selector in the long mode, the relays' contact closure is the same duration as the input's closure duration. In the short mode, the output is closed for a approximately 100 milliseconds regardless of the input's closure duration. Red and green LEDs, one for each channel, are located in the customer's compartment and light alternately depending upon input's status. The use of LEDs allows a rapid visual check of the system's performance by inexperienced personnel without requiring any additional test equipment. Because of the redundant, coordinated fusing in both the utility's and customer's compartments, the meter shop service coordinator can usually determine the location of the service problem as to either utility or customer responsibility by the simple question "are the LEDs flashing". The double "K" lead coordinated fusing of the CIR-22PS's output will prevent damage to the relay under almost any condition a user might cause such as that caused by excessive current, incorrect wiring, etc. The CIR-22PS' robust solid state switching device is rated at 800V and 750mA giving maximum protection from lightning or transient voltage damage. The CIR-22PS has built-in transient protection for the solid state switching devices that eliminates the need for external or off-the-board transient suppressors.



FUNCTIONAL SUMMARY

	IN	OUT
#	2	2
TYPE	2 or 3 Wire	3 Wire
FORM	A or C	C

CIR-22PS



SELF-CONTAINED RELAYS (OUTDOOR) - SOLID STATE

CIR-22PS CUSTOMER INTERFACE RELAY

FORMERLY THE CIR-22S & CIR-22A/B

SPECIFICATIONS

ELECTRICAL

Power Input:	120, 208-277 VAC. Burden: 10 mA at 120 VAC
Pulse Input:	Two Form A (2-Wire) or C (3-Wire) input with +13VDC wetting voltage on the "Y" and "Z" terminals.
Pulse Output:	Two sets of dry contact solid state outputs located in the customer's compartment. The contacts are solid state "no bounce" relays rated at 250VACVDC at 1/2 Amp. The maximum rating of the contacts is 100 VA. Factory fused at 1/4 amp. (3AG)
Contact Resistance:	2.3 ohms maximum, 1.7 ohms typical
Insulation Resistance:	50 megohms typical
Operate and Release Time:	Turn on-time - 8 mS typical; 20 mS MAX Turn off-time - 1 mS typical; 5 mS MAX
Input/Output Isolation Voltage:	2500Vrms

MECHANICAL

Mounting:	Any position
Size:	9.0" wide, 11.0" high, 4.50" deep
Weight:	9 pounds
Type/Material:	NEMA 4X Fiberglass Case

TEMPERATURE

Temperature Range:	-38° C to +85° C, -36.4° F to +158° F
Humidity:	0 to 98% non-condensing

AVAILABLE OPTIONS

Input Voltages:	24 VAC/24VDC, 125VDC
-----------------	----------------------

CIR-22PS



SELF-CONTAINED RELAYS (OUTDOOR) - SOLID STATE

CIR-24PS CUSTOMER INTERFACE RELAY

FORMERLY THE CIR-24S

DESCRIPTION

The CIR-24PS Customer Interface Relay provides four isolated solid state dry Form C contacts from two Form A or C inputs. Each set of output contacts may be used as either a Form A (K & Y) or a Form C (K, Y, & Z) contact. The typical application is the utility's interface between the KWH meter and a customer-owned energy control system where two types of pulses are used. For example, one input channel might be for watt-hour pulses and the second input channel for var-hour pulses. The CIR-22 provides two independent isolation relay channels in one ready-to-use weather-resistant package.

The CIR-24PS is internally divided into two compartments. Once installed, the upper compartment is normally locked and only accessible to utility metering personnel. It contains all of the electronics along with fusing that is coordinated with the fuse contained within the customer compartment. The lower compartment (customer compartment) contains a terminal strip, fusing, and output status LEDs.

Using jumper selector, the inputs can be configured as 2-Wire or 3-Wire inputs and the outputs can be configured in the "Long" or "Short" pulse output mode. With the output selector in the long mode, the relays' contact closure is the same duration as the input's closure duration. In the short mode, the output is closed for a approximately 100 milliseconds regardless of the input's closure duration. Red and green LEDs, one for each channel, are located in the customer's compartment and light alternately depending upon input's status.

Each output is assigned to one of the two inputs by means of a switch, thereby allowing flexibility in directing pulses to the appropriate output.

The use of LEDs allows a rapid visual check of the system's performance by inexperienced personnel without requiring any additional test equipment. Because of the redundant, coordinated fusing in both the utility's and customer's compartments, the meter shop service coordinator can usually determine the location of the service problem as to either utility or customer responsibility by the simple question "are the LEDs flashing". The double "K" lead coordinated fusing of the CIR-24PS's output will prevent damage to the relay under almost any condition a user might cause such as that caused by excessive current, incorrect wiring, etc. The CIR-24PS' robust solid state switching device is rated at 800V and 750mA giving maximum protection from lightning or transient voltage damage. The CIR-24PS has built-in transient protection for the solid state switching devices that eliminates the need for external or off-the-board transient suppressors.



FUNCTIONAL SUMMARY

	IN	OUT
#	2	4
TYPE	2 or 3 Wire	3 Wire
FORM	A or C	C

CIR-24PS



SELF-CONTAINED RELAYS (OUTDOOR) - SOLID STATE

CIR-24PS CUSTOMER INTERFACE RELAY

FORMERLY THE CIR-24S

SPECIFICATIONS

ELECTRICAL

Power Input:	120, 208-277 VAC. Burden: 10 mA at 120 VAC
Pulse Inputs:	Two Form A (2-Wire) or C (3-Wire) input with +13VDC wetting voltage on the "Y" and "Z" terminals.
Pulse Outputs:	Four sets of dry contact solid state outputs – two located in the customer's compartment and two in the utility compartment. The contacts are solid state "no bounce" relays rated at 250VACVDC at 1/2 Amp. The maximum rating of the contacts is 100 VA. Factory fused at 1/4 amp. (3AG)
Contact On-State Resistance:	2.3 ohms maximum, 1.7 ohms typical
Insulation Resistance:	50 megohms typical
Operate and Release Time:	Turn on-time - 8 mS typical; 20 mS MAX Turn off-time - 1 mS typical; 5 mS MAX
Input/Output Isolation Voltage:	2500Vrms

MECHANICAL

Mounting:	Any position
Size:	9.0" wide, 11.0" high, 4.50" deep
Weight:	9 pounds
Type/Material:	NEMA 4X Fiberglass Case

TEMPERATURE

Temperature Range:	-38° C to +85° C, -36.4° F to +158° F
Humidity:	0 to 98% non-condensing

AVAILABLE OPTIONS

Input Voltages:	24 VAC/24VDC, 125VDC
-----------------	----------------------

CIR-24PS



SELF-CONTAINED RELAYS (OUTDOOR) - SOLID STATE

CIR-24NG CUSTOMER INTERFACE RELAY

FUNCTIONAL SUMMARY

	IN	OUT
#	2	4
TYPE	2 or 3 Wire	2 or 3 Wire
FORM	A or C	A or C

CIR-24NG

The CIR-24NG Customer Interface Relay provides four isolated solid-state Form A or C dry-contact outputs from two Form A or C inputs. Each set of output contacts may be used as either a Form A (K & Y) or a Form C (K, Y, & Z) contact. The typical application is the utility's interface between the KWH meter and a customer-owned energy control system where two types of pulses are used. For example, one input channel might be for watt-hour pulses and the second input channel for var-hour pulses. The CIR-24NG provides two independent isolation relay channels in one ready-to-use weather-resistant package.

The CIR-24NG is internally divided into two compartments. Once installed, the upper compartment is normally locked and only accessible to utility metering personnel. It contains the Power Supply input terminals, all of the system electronics and programming accessibility. The lower compartment (customer compartment) contains an Output terminal strip, fusing, and output status LEDs. Using SSI's Universal Programmer software, the inputs and outputs can be configured as 2-Wire(Form A) or 3-Wire(Form C) and each output mapped to an input. Pulse output timing for Form A pulse widths can also be set. With the outputs having like form Settings to the inputs, the channel is in Normal mode and the outputs follow the inputs with equal time. If the outputs are Form A, a fixed pulse width may be programmed into the that particular relay output, making it compatible with certain instruments' minimum pulse width requirements. If the outputs have the opposite setting to the input they are following, the that channel is in the conversion mode, either A to C or C to A while keeping the pulse value constant.

Red and green LEDs, one for each input and output, are located next to the terminal blocks for good visibility and easy interpretation of the state of each input and output.

The CIR-24NG' robust solid-state switching device is rated at 1000V and 180mA giving maximum protection from lightning or transient voltage damage. The CIR-24NG has built-in transient protection for the solid-state switching devices that eliminates the need for external or off-the-board transient suppressors.





SELF-CONTAINED RELAYS (OUTDOOR) - SOLID STATE

CIR-24NG CUSTOMER INTERFACE RELAY

FORMERLY THE CIR-24S

SPECIFICATIONS

ELECTRICAL

Power Input:	120, 208-277 VAC. Burden: 10 mA at 120 VAC
Pulse Inputs:	Two Form A (2-Wire) or C (3-Wire) input with +13VDC wetting voltage on the "Y" and "Z" terminals.
Pulse Outputs:	Four sets of dry contact solid state outputs – located in the customer compartment. The contacts are solid state "no bounce" relays rated at 125VACVDC at 1/4 Amp. The maximum rating of the contacts is 1500 mW. Factory fused at 1/4 amp. (3AG)
Contact On-State Resistance:	12.3 ohms maximum, 18 ohms typical
Insulation Resistance:	50 megohms typical
Operate and Release Time:	Turn on-time - 10 mS MAX Turn off-time - 5 mS MAX
Input/Output Isolation Voltage:	2500Vrms

MECHANICAL

Mounting:	Any position
Size:	9.0" wide, 11.0" high, 4.50" deep
Weight:	9 pounds
Type/Material:	NEMA 4X Fiberglass Case

TEMPERATURE

Temperature Range:	-38° C to +85° C, -36.4° F to +158° F
Humidity:	0 to 98% non-condensing

AVAILABLE OPTIONS

Input Voltages:	24 VAC/24VDC, 125VDC
-----------------	----------------------

CIR-24NG



SELF-CONTAINED RELAYS (OUTDOOR) - SOLID STATE CIR-44 CUSTOMER INTERFACE RELAY

FUNCTIONAL SUMMARY

	IN	OUT
#	4	4
TYPE	2 Wire	2 Wire
FORM	A	A

CIR-44

Originally manufactured by the Southern Companies as the Model 44, for their own use, it became part of the SSI family in March 2024. This “Super Relay” will do just about any task required in pulse metering from simple multi-channel pulse isolation to totalizing with positive or negative pulses.

The CIR-44’s four isolated solid-state Form A contact outputs are independently programmed to follow one of the four Form A inputs. The typical application is the utility’s interface between the KWH meter and a customer-owned energy control system where two to four types of pulses are used. For example, one input channel might be for watt-hour pulses and the second input channel for var-hour pulses. The CIR-44 provides four independent isolation relay channels in one ready-to-use weather-resistant package.



Each of the four channels of the CIR-44 has three operating modes, Normal Pass-thru, Pass-Through with Value Conversion, or Positive or Negative Totalizing. In the Normal Pass-thru Mode, Form A inputs are passed to the assigned Form A output(s). In Pass-thru Value Conversion Mode, Form A inputs are assigned a pulse value. When the value of the input(s) reaches a corresponding output value a pulse is passed to the assigned output(s). In Totalizing mode, the inputs are assigned a positive or negative value. Once the corresponding total output value is reached, a pulse is passed to the assigned output. Each of the four outputs can be “mapped” to any of the four inputs.

The CIR-44 is internally divided into two compartments. Once installed, the upper compartment is normally locked and only accessible to utility metering personnel. It contains the Power Supply input terminals, all of the system electronics and programming accessibility. The lower compartment (customer compartment) contains an Output terminal strip and status LEDs. Using SSI’s CIR-44 Programmer software, the inputs and outputs can be configured, and each output mapped to an input. Form A pulse width output timing can also be set. Each output also contains a solid state automatic resettable fuse.

Red and green LEDs, one for each input and output, are located next to the terminal block in the customer compartment for good visibility and easy interpretation of the state of each input and output.

The CIR-44’ robust solid-state switching device is rated at 600V and 150mA giving maximum protection from lightning or transient voltage damage. The CIR-44 has built-in transient protection for the solid-state switching devices that eliminates the need for external or off-the-board transient suppressors.



SELF-CONTAINED RELAYS (OUTDOOR) - SOLID STATE
CIR-44 CUSTOMER INTERFACE RELAY

SPECIFICATIONS

ELECTRICAL

Power Input:	120-277 VAC. Burden: 10 mA at 120 VAC
Pulse Inputs:	Four Form A (2-Wire) inputs with +12VDC wetting voltage on the "Y" terminal
Pulse Outputs:	Four sets of dry-contact solid state outputs located in the customer's compartment. The contacts are solid state "no bounce" relays rated at 250VACVDC at 1/10th Amp. The maximum rating of the contacts is 1500mW. Factory fused at 150 mA.
Contact On-State Resistance:	6 ohms maximum, 3.5 ohms typical
Insulation Resistance:	50 megohms typical
Operate and Release Time:	Turn On Time - 5 mS MAX, 2.2mS Typical Turn Off Time - 2 mS MAX, .15mS Typical
Input/Output Isolation Voltage:	4000Vrms

MECHANICAL

Mounting:	Any position
Size:	9.0" wide, 11.0" high, 4.50" deep
Weight:	9 pounds
Type/Material:	NEMA 4X Fiberglass Case

TEMPERATURE

Temperature Range:	38° C to +70° C, -38.4° F to +158° F
Humidity:	0 to 98% non-condensing

AVAILABLE OPTIONS

Input Voltages:	DCS-1: 125VDC DCS-2: 15-48VDC 24VAC 12 VAC/12VDC Other Voltage: Contact Factory
-----------------	---

CIR-44



SSI TOTALIZERS

MPT-2C METERING PULSE TOTALIZER

REPLACES THE MPT-2C

DESCRIPTION

The MPT-2C metering pulse totalizer is designed to provide the totalized pulse output from two 2-wire (Form A) or 3-wire (Form C) pulse input sources. Two 2-wire Form A or 3-wire Form C (K, Y, & Z) outputs from isolated, solid state, dry contact relays are provided. Inputs are signed + or - to provide additive and subtractive capability.



FUNCTIONAL SUMMARY

	IN	OUT
#	2	2
TYPE	2 or 3 Wire	2 or 3 Wire
FORM	A or C	A or C

The MPT-2C's output module may be operated in 1-channel or 2-channel mode. In 1-channel mode, the MPT-2C operates with a single KYZ output channel. In 2-channel mode, the MPT-2C operates with two independent KY output channels, each having a unique output value. In both configurations, there are two physical outputs on each channel, eliminating the need for an additional "splitting" or pulse duplicating relay.

Typical applications include interfaces between utility metering devices and customer-owned energy control systems, demand recorder applications, and supervisory control systems (SCADA) interfaces. The MPT-2C pulse totalizer may also be used as a pulse value translator if it is desirable to translate odd pulse values such as 0.1234 KWH/pulse to an even value, 0.5000 KWH/pulse. The pulse signal inputs to the MPT-2C is by two sets of "Y" & "Z" leads with a common "K" lead.

The MPT-2C provides a sense voltage of +13VDC to the two pulse sending units, normally two electric meters. The MPT-2C's inputs may be assigned a four-digit pulse value which can be set from 0001 to 9999. The output value setting is a six digit number between 000001 to 999999. Both the input and output values may be field set without the use of any external devices. All settings are saved in non-volatile memory. In addition, the minimum time between output pulses may be set in 10 millisecond increments between 20 milliseconds and 1000 milliseconds.

An LCD display contained within the unit displays the status of each of the inputs and the output as a Y or Z. In addition, all programming of system values is done using the LCD display and pushbutton switches. With a software debouncing technique, all inputs are first checked for the correct sequence and then a minimum time of contact closure duration to assure a maximum noise rejection. The "K" lead of the MPT-2C's output is fused to prevent damage to the relay under almost any conditions a user might cause such as excessive current, incorrect wiring, etc.

The MPT-2C has built-in MOV transient protection for the solid state relay contacts which eliminates the need for external or off-the-board transient suppressors. All component parts of the MPT-2C, which have power applied to them with the exception of the input/output terminal strip, are enclosed in a polycarbonate cover for maximum protection. The mounting base plate is also made of polycarbonate and offers excellent electrical insulation.

MPT-2C



SSI TOTALIZERS

MPT-2C METERING PULSE TOTALIZER

REPLACES THE MPT-2C

SPECIFICATIONS

ELECTRICAL

Power Input:	120, 208-277 VAC. Burden: 10 mA at 120 VAC
Pulse Input:	Two 2-wire (Form A) or 3-wire (Form C) inputs. "K" terminal are common return from meter; "Y" and "Z" terminals are pulled-up to a sense voltage of +13 VDC. Compatible with dry-contact mechanical, electro-mechanical or semiconductor outputs (i.e. open connector transistor or MOSFET transistor).
Pulse Output:	Two sets of Form C (K, Y, & Z) dry contacts for energy pulses rated at 100mA at 120VAC/VDC. Factory fused at 1/10 Amp with 3AG fuses. 800mW maximum contact power.
Contact Resistance:	25 ohms maximum, 18 typical
Insulation Resistance:	50 megohms typical
Operate and Release Time:	1 to 2 milliseconds typical
Input/Output Isolation Voltage:	2500Vrms

MECHANICAL

Mounting:	Any position
Size:	3.50" wide, 7.20" high, 1.50" deep
Weight:	13 ounces

TEMPERATURE

Temperature Range:	-38° C to +70° C, -36.4° F to +158° F
Humidity:	0 to 98% non-condensing

AVAILABLE OPTIONS

Input Voltages:	125VDC with DCS-1; 15-48VDC with DCS-2; contact factory for other voltages
-----------------	--

MPT-2C



SSI TOTALIZERS

MPT-4C METERING PULSE TOTALIZER

REPLACES THE MPT-4B-PS
AND MPT-4SB-PS

DESCRIPTION

The MPT-4C metering pulse totalizer is designed to provide the totaled pulse values from four 2-Wire (Form A) or 3-Wire (Form C) input pulse sources. Two 2-Wire Form A or 3-wire Form C (K, Y, & Z) outputs from isolated, solid state, dry contact relays are provided. Inputs are signed + or - to provide additive and subtractive capability.



The MPT-4C's output module may be operated in 1-channel or 2-channel mode. In 1-channel mode, the MPT-4C operates with a single KYZ output channel. In 2-channel mode, the MPT-4C operates with two independent KY output channels, each having a unique output value. In both configurations, there are two physical outputs on each channel, eliminating the need for an additional "splitting" or pulse duplicating relay.

The MPT-4C incorporates a peak demand software module that tracks the average kW demand in any interval and captures the peak demand for later reading in non-volatile memory. A separate demand reset allows for resetting of the peak demand module only. An EOI signal is provided by one of the four meters to signal the end of each interval and the start of the next.

Typical applications include interfaces between utility metering devices and customer-owned energy control systems, demand billing applications, and supervisory control systems (SCADA) interfaces. The pulse signal inputs to the MPT-4C is by four sets of "Y" & "Z" leads with a common "K" lead.

The MPT-4C provides a "wetting" voltage of +13VDC to the four pulse sending units, normally electric meters. Each of the MPT-4C's inputs may be assigned a four digit pulse value which can be set from 0001 to 9999. The output value setting is a six digit number from 000001 to 999999. Both the input and output values may be field set without the use of any external devices. All settings are saved in non-volatile memory. In addition, the minimum time between output pulses may be set in 10 milliseconds increments between 20 milliseconds and 1000 milliseconds.

An LCD display contained within the unit displays the status of each of the inputs and the output as a Y or Z when not being used in the setting of the pulse multiplier values. Using software debouncing technique, all inputs are first checked for the correct sequence and then a minimal time of contact closure duration to assure a maximum noise rejection. The "K" lead of the MPT-4C's outputs are fused to prevent damage to the relay under almost any conditions a user might cause such as excessive current, incorrect wiring, etc.

The MPT-4C has built-in MOV transient protection for the solid state relay contacts which eliminates the need for external or off-the-board transient suppressors. All component parts of the MPT-4C, which have power applied to them with the exception of the input/output terminal strip, are enclosed in a polycarbonate cover for maximum protection. The mounting base plate is also made of polycarbonate and offers excellent electrical insulation.

FUNCTIONAL SUMMARY

	IN	OUT
#	4	2
TYPE	2 or 3 Wire	2 or 3 Wire
FORM	A or C	A or C

MPT-4C



SSI TOTALIZERS

MPT-4C METERING PULSE TOTALIZER

REPLACES THE MPT-4B-PS
AND MPT-4SB-PS

SPECIFICATIONS

ELECTRICAL

Power Input:	120, 208-277 VAC. Burden: 10 mA at 120 VAC
Pulse Input:	Four 2-wire Form A or 3-wire Form C inputs. "K" terminal are common return from meter; "Y" and "Z" terminals are pulled-up to a sense voltage of +13 VDC. Compatible with dry-contact mechanical, electro-mechanical or semiconductor outputs (i.e. open connector transistor or MOSFET transistor).
Pulse Output:	Two sets of Form C (K, Y, & Z) dry contacts or two independent Form A channels with two outputs each for energy pulses rated at 100mA at 120VAC/ VDC. Factory fused at 1/10 Amp with 3AG fuses. 800mW maximum contact power.
Contact Resistance:	25 ohms maximum, 18 typical
Insulation Resistance:	50 megohms typical
Operate and Release Time:	1 to 2 milliseconds typical
Input/Output Isolation Voltage:	2500Vrms

MECHANICAL

Mounting:	Any position
Size:	3.50" wide, 7.20" high, 1.50" deep
Weight:	13 ounces

TEMPERATURE

Temperature Range:	-38° C to +70° C, -36.4° F to +158° F
Humidity:	0 to 98% non-condensing

AVAILABLE OPTIONS

Input Voltages:	125VDC with DCS-1; 15-48VDC with DCS-2; contact factory for other voltages
-----------------	--

MPT-4C



SSI TOTALIZERS

MPT-8C METERING PULSE TOTALIZER

REPLACES THE MPT-8B-PS

DESCRIPTION

The MPT-8C metering pulse totalizer is designed to provide the totaled pulse values from eight 2-Wire Form A input pulse sources. Two 2-Wire Form A or 3-wire Form C (K, Y, & Z) outputs from isolated, solid state, dry contact relays are provided. Inputs are signed + or - to provide additive and subtractive capability.



FUNCTIONAL SUMMARY

	IN	OUT
#	8	2
TYPE	2 Wire	2 or 3 Wire
FORM	A	A or C

The MPT-8C's output module may be operated in 1-channel or 2-channel mode. In 1-channel mode the MPT-8C operates with a single KYZ output channel. In 2-channel mode, the MPT-8C operates with two independent KY output channels, with each having a unique output value. In both configurations, there are two physical outputs, eliminating the need for a "splitting" or pulse duplicating relay.

The MPT-8C incorporates a peak demand software module which keeps track of the average kW demand in any interval and saves the peak demand for later reading and unit a manual reset. An EOI signal is provided by one of the four meters to signal the end of each interval and the start of the next.

Typical applications include interfaces between utility metering devices and customer-owned energy control systems, demand billing applications, and supervisory control systems (SCADA) interfaces. The pulse signal inputs to the MPT-8C is by four sets of "Y" & "Z" leads with a common "K" lead.

The MPT-8C provides a "wetting" voltage of +13VDC to the four pulse sending sources, normally electric meters. Each of the MPT-8C's inputs may be assigned a four digit pulse value which can be set from 0001 to 9999. The output value setting is a six digit number from 000001 to 999999. Both the input and output values may be field set without the use of any external devices. All settings are saved in non-volatile memory. In addition, the minimum time between output pulses may be set in 10 milliseconds increments between 20 milliseconds and 1000 milliseconds.

An LCD display contained within the unit displays the status of each of the inputs and the output as a Y or Z when not being used in the setting of the pulse multiplier values. Using software debouncing technique, all inputs are first checked for the correct sequence and then a minimal time of contact closure duration to assure a maximum noise rejection. The "K" lead of the MPT-8C's output is fused to prevent damage to the relay under almost any conditions a user might cause such as excessive current, incorrect wiring, etc.

The MPT-8C has built-in MOV transient protection for the solid state relay contacts which eliminates the need for external or off-the-board transient suppressors. All component parts of the MPT-8C, which have power applied to them with the exception of the input/output terminal strip, are enclosed in a polycarbonate cover for maximum protection. The mounting base plate is also made of polycarbonate and offers excellent electrical insulation.

MPT-8C

SOLID STATE INSTRUMENTS A Product Family Owned by RADIAN RESEARCH

3852 Fortune Dr. • Lafayette, IN • Ph: 765-449-5500 • Fax: 765-448-4614

www.radianresearch.com



SSI TOTALIZERS

MPT-8C METERING PULSE TOTALIZER

REPLACES THE MPT-8B-PS

SPECIFICATIONS

ELECTRICAL

Power Input:	120, 208-277 VAC. Burden: 10 mA at 120 VAC
Pulse Input:	Eight 2-wire Form A pulse inputs. "K" terminal are common return from meter; "Y" terminals are pulled-up to a sense voltage of +13 VDC. Compatible with dry-contact mechanical, electro-mechanical or semiconductor outputs (i.e. open connector transistor or MOSFET transistor).
Pulse Output:	Two sets of Form C (K, Y, & Z) dry contacts or two independent Form A channels with two outputs each for energy pulses rated at 100mA at 120VAC/ VDC. Factory fused at 1/10 Amp with 3AG fuses. 800mW maximum contact power.
Contact Resistance:	25 ohms maximum, 18 typical
Insulation Resistance:	50 megohms typical
Operate and Release Time:	1 to 2 milliseconds typical
Input/Output Isolation Voltage:	2500Vrms

MECHANICAL

Mounting:	Any position
Size:	3.50" wide, 7.20" high, 1.50" deep
Weight:	13 ounces

TEMPERATURE

Temperature Range:	-38° C to +70° C, -36.4° F to +158° F
Humidity:	0 to 98% non-condensing

AVAILABLE OPTIONS

Input Voltages:	125VDC with DCS-1; 15-48VDC with DCS-2; contact factory for other voltages
-----------------	--

MPT-8C



SSI TOTALIZERS

MPT-10C METERING PULSE TOTALIZER

DESCRIPTION

The MPT-10C Metering Pulse Totalizer is designed to provide the totaled pulse output from ten 2-wire (Form A) pulse input sources. Two 2-wire Form A (KY) isolated dry-contact solid state relay outputs are provided. Inputs are signed + or – to provide additive and subtractive capability.



The MPT-10C provides a “pulled up” sense voltage for each Yin input terminal of +12VDC to the ten sending source contacts, normally electric meters. The MPT-10C’s inputs have a unique four digit signed value which can be set between the value of 0000 to 9999. The Pulse output value settings are a six-digit numbers between 000000 to 999999. Both the input and output values may be field set without the use of any external devices.

The MPT-10C has two independent Form A (KY) outputs, each capable of having a unique output value. The two outputs are electrically isolated from each other, eliminating the need for a “splitting” or pulse isolation relay. In addition, the minimum time between output pulses may be set in 10 millisecond increments between 20 milliseconds and 1000 milliseconds, ensuring that output pulses are not too fast for the equipment or telemetry receiving pulses from the MPT-10C. The MPT-10C’s outputs may be operated in the Toggle mode or the Momentary mode. In Toggle mode, the output changes state upon each pulse being outputted, thereby emulating one side (KY) of a standard 3-wire Form C KYZ output. In Momentary mode, the output contact closes for a specified number of milliseconds from 20 to 1000 mS.

Typical applications include interfaces between utility metering devices and customer-owned energy control systems, demand recorder applications, and supervisory control systems (SCADA) interfaces. The MPT-10C pulse totalizer may also be used as a pulse value translator if it is desirable to translate odd pulse values such as 0.1234 KWH/pulse to an even value, 0.5000 KWH/pulse. The pulse signal inputs to the MPT-10C is by five sets of “Y” leads with a common “K” lead.

An LCD display contained within the unit displays the status of each of the inputs and the output as a Y or Z. In addition, all programming of system values is done using the LCD display and pushbutton switches. With a software debouncing technique, all inputs are first checked for the correct sequence and then a minimal time of contact closure duration to assure a maximum noise rejection. The “K” lead of the MPT-10C’s output is fused to prevent damage to the relay under almost any conditions a user might cause such as excessive current, incorrect wiring, etc.

The MPT-10C has built-in MOV transient protection for the solid-state relay contacts which eliminates the need for external or off-the-board transient suppressors. All component parts of the MPT-10C, which have power applied to them with the exception of the input/output terminal strip, are enclosed in a polycarbonate cover for maximum protection. The mounting base plate is also made of polycarbonate and offers excellent electrical insulation.

FUNCTIONAL SUMMARY

	IN	OUT
#	10	2
TYPE	2 Wire	2 Wire
FORM	A	A

TYPE
FORM

MPT-10C

SOLID STATE INSTRUMENTS A Product Family Owned by RADIAN RESEARCH

3852 Fortune Dr. • Lafayette, IN • Ph: 765-449-5500 • Fax: 765-448-4614

www.radianresearch.com



SSI TOTALIZERS

MPT-10C METERING PULSE TOTALIZER

SPECIFICATIONS

ELECTRICAL

Power Input:	120-277VAC Autoranging. Burden: ~10 mA at 120 VAC
Pulse Input:	Ten 2-wire Form A inputs. "K" terminal are common return from meter; "Y" terminals are pulled-up to a sense voltage of +12VDC. Compatible with dry-contact mechanical, electro-mechanical or semiconductor outputs (i.e. open connector transistor or MOSFET transistor).
Pulse Output:	Two sets of Form A (K & Y) dry contacts for energy pulses rated at 100mA at 120VAC/VDC. Factory fused at 1/10 Amp with 3AG fuses. 800mW maximum contact power.
Contact Resistance:	25 ohms maximum, 18 typical
Insulation Resistance:	50 megohms typical
Operate and Release Time:	1 to 2 milliseconds typical
Input/Output Isolation Voltage:	2500Vrms

MECHANICAL

Mounting:	Any position
Size:	3.50" wide, 7.20" high, 1.50" deep
Weight:	13 ounces

TEMPERATURE

Temperature Range:	-38° C to +70° C, -38.4° F to +158° F
Humidity:	0 to 98% non-condensing

AVAILABLE OPTIONS

Input Voltages:	12VDC; 125VDC with DCS-1; 15-48VDC with DCS-2; contact factory for other voltages
-----------------	---

MPT-10C



SSI TOTALIZERS

MPT-440 METERING PULSE TOTALIZER

DESCRIPTION



FUNCTIONAL SUMMARY

	IN	OUT
#	4	6
TYPE	2 or 3 Wire	2 or 3 Wire
FORM	A or C	A or C

The MPT-440 metering pulse totalizer and quad isolation relay is designed to provide the totalized pulse values from four 2-Wire (Form A) or 3-Wire (Form C) input pulse sources and allow each pulse into to “pass through” to an isolated output. Four 2-Wire Form A or 3-wire Form C (K, Y, & Z) outputs are provided, one for each input, plus two additional from isolated, solid state, dry contact relays are provided. Inputs are signed + or – to provide additive and subtractive capability.

The MPT-440’s output module may be operated in 1-channel or 2-channel mode. In 1-channel mode, the MPT-440 operates with a single KYZ output channel. In 2-channel mode, the MPT-440 operates with two independent KY output channels, each having a unique output value. In both configurations, there are two physical outputs on each channel, eliminating the need for an additional “splitting” or pulse duplicating relay.

The MPT-440 incorporates a peak demand software module that tracks the average kW demand in any interval and captures the peak demand for later reading in non-volatile memory. A separate demand reset allows for resetting of the peak demand module only. An EOI signal is provided by one of the four meters to signal the end of each interval and the start of the next.

Typical include interfaces between utility metering devices and customer-owned energy control systems, demand billing applications, and supervisory control systems (SCADA) interfaces. The pulse signal inputs to the MPT-440 is by four sets of “Y” & “Z” leads with a common “K” lead.

The MPT-440 provides a “wetting” voltage of +13VDC to the four pulse sending units, normally electric meters. Each of the MPT-440’s inputs may be assigned a four digit pulse value which can be set from .0001 to 99999. The output value setting is a six digit number from .000001 to 999999. Both the input and output values may be field set without the use of any external devices. All settings are saved in non-volatile memory. In addition, the minimum time between output pulses may be set in 10 milliseconds increments between 20 milliseconds and 1000 milliseconds.

An LCD display contained within the unit displays the status of each of the inputs and the output as a Y or Z when not being used in the setting of the pulse multiplier values. Using software debouncing technique, all inputs are first checked for the correct sequence and then a minimal time of contact closure duration to assure a maximum noise rejection. The “K” lead of the MPT-440’s outputs are fused to prevent damage to the relay under almost any conditions a user might cause such as excessive current, incorrect wiring, etc.

The MPT-440 has built-in MOV transient protection for the solid state relay contacts which eliminates the need for external or off-the-board transient suppressors. All component parts of the MPT-440, which have power applied to them with the exception of the input/output terminal strip, are enclosed in a polycarbonate cover for maximum protection. The mounting base plate is also made of polycarbonate and offers excellent electrical insulation.

MPT-440

SOLID STATE INSTRUMENTS A Product Family Owned by RADIAN RESEARCH

3852 Fortune Dr. • Lafayette, IN • Ph: 765-449-5500 • Fax: 765-448-4614

www.radianresearch.com



SSI TOTALIZERS

MPT-440 METERING PULSE TOTALIZER

SPECIFICATIONS

ELECTRICAL

Power Input:	120, 208-277 VAC. Burden: 10 mA at 120 VAC
Pulse Input:	Four 2-wire Form A or 3-wire Form C inputs. "K" terminal are common return from meter; "Y" and "Z" terminals are pulled-up to a sense voltage of +13 VDC. Compatible with dry-contact mechanical, electro-mechanical or semiconductor outputs (i.e. open-connector bi-polar NPN transistor or open-drain FET transistor).
Pulse Output:	Six Form C (K,Y, & Z) outputs: Four "straight-thru" isolated outputs, one for each pulse input; Two totalized outputs-configurable as two Form C (K, Y, & Z) or four Form A(independent K&Y or K&Z); Outputs are dry-contact for energy pulses rated at 100mA at 120VAC/VDC. Factory fused at 1/10 Amp with 3AG fuses. 800mW maximum contact power.
Output Contact Type:	Solid State MOSFET
Output Contact Resistance:	25 ohms maximum, 18 typical
Insulation Resistance:	50 megohms typical
Operate and Release Time:	1 to 2 milliseconds typical
Input/Output Isolation Voltage:	2500Vrms

MECHANICAL

Mounting:	Any position
Size:	7" wide, 9" high, 2" deep
Weight:	2 pounds

TEMPERATURE

Temperature Range:	-38° C to +70° C, -38.4° F to +158° F
Humidity:	0 to 98% non-condensing

AVAILABLE OPTIONS

Input Voltages:	Contact factory
-----------------	-----------------

MPT-440



REGISTERS/TOTALIZERS

NPR-1 NET METERING REGISTER RELAY

DESCRIPTION

The NPR-1 Net Pulse Register is a simplified pulse totalizer designed to provide a totalized net pulse count from up to four 2-Wire (Form A) input pulse sources. It is designed to work with an End-of-Interval (EOI) pulse input that coordinates and synchronizes the operation of the NPR-1. To simplify the operation of the NPR-1 all pulse values (weights) must be equal to each other, and are assigned a positive or negative pulse weight.



FUNCTIONAL SUMMARY

	IN	OUT
#	4	1
TYPE	2 Wire	2 Wire
FORM	A	A

NPR-1

Once an EOI pulse is received, the NPR-1 begins a new interval and counts positive and negative pulses in a count register. A positive pulse increments the count register by 1 while a negative pulse decrements the count register by 1. At the end of the demand interval, the EOI input line is activated and the existing net count is transferred to an output register. Once the new interval is started, the normal count pulse counting operation resumes. While this is occurring, the output register begins outputting the number of pulses equal to the net count at a rate of 5 pulses per second. These are generally fed into an electric meter pulse input, recorder, SCADA system or other telemetry device. If at the end of a demand interval the net count is zero or negative, no pulses are outputted to the external device.

Two Form A (K&Y) solid state isolated, dry-contact outputs are provided. Typical applications include interfaces between utility metering devices, demand recorder applications, and supervisory control systems (SCADA) interfaces. The NPR-1 provides a sense voltage of +13 VDC to the four K-Y pulse sending source contacts, normally four meters, as well as to the EOI pulse input.

Installation and setup are amazingly simple since the only programmable parameters are to set the pulse weight as positive or negative. Non-volatile EEPROM memory “remembers” all register values in the event of power loss. Upon power-up all register values are restored, so there is no loss of pulse counts or register values.

The “K” lead of the NPR-1’s outputs are fused to prevent damage to the relay under almost any condition a user might cause such as excessive current, incorrect wiring, etc. The NPR-1 utilizes SSI’s standard built-in transient protection for the solid state relay contacts that eliminates the need for external or off-the-board transient suppressors. All component parts of the NPR-1, which have power applied to them with the exception of the input/output terminal strip, are enclosed in a polycarbonate cover for maximum protection. The mounting base plate is also made of polycarbonate and offers excellent electrical insulation.



REGISTERS/TOTALIZERS

NPR-1 NET METERING REGISTER RELAY

SPECIFICATIONS

ELECTRICAL

Power Input:	120, 208-277 VAC. Burden: 4 mA at 120 VAC
Pulse Input:	Four 2-Wire Form A inputs. The "K" input terminal is the common return for all meters. The "Y" terminal is "pulled-up" to +13 VDC making it compatible with open-collector transistors, open-drain FETs or virtually any kind of KYZ switch (i.e. mechanical, electro-mechanical or solid state).
Pulse Output:	Two dry Form A contacts (K & Y). Factory fused at 1/10 Amp with 3AG fuses. Solid state contacts have a maximum output rating of 250VAC/VDC at 1/10 Amp. The maximum power rating of the contacts is 800 MW, without exceeding the maximum voltage and current ratings of the solid state switch.
Contact On-State Resistance:	25 ohms maximum, 18 ohms typical
Input to Output Isolation Voltage:	2500Vrms
Operate and Release Time:	3 milliseconds max. operate (turn-on) 1 milliseconds max. release (turn off)

MECHANICAL

Mounting:	Any position
Size:	3.50" wide, 7.20" high, 1.50" deep
Weight:	1 pound

TEMPERATURE

Temperature Range:	-38° C to +70° C, -36.4° F to +158° F
Humidity:	0 to 98% non-condensing

AVAILABLE OPTIONS

Input Voltages:	Contact factory for input voltages.
-----------------	-------------------------------------

NPR-1



REGISTERS/TOTALIZERS

NPR-8 NET METERING REGISTER RELAY

DESCRIPTION

The NPR-8 Net Pulse Register is a simplified pulse totalizer designed to provide a totalized “net” pulse count from up to eight 2-Wire (Form A) input pulse sources. It is designed to work with an End-of-Interval (EOI) pulse input that coordinates and synchronizes the operation of the NPR-8. To simplify the operation of the NPR-8 all pulse values (weights) must be equal to each other, and are assigned a positive or negative sign for the pulse weight.



FUNCTIONAL SUMMARY

#

TYPE

FORM

IN	OUT
8	2
2 Wire	2 Wire
A	A

NPR-8

Once an EOI pulse is received, the NPR-8 begins a new interval and counts positive and negative pulses in a Count Register. Each time a positive pulse is received on one of the designated positive inputs, the Count Register increments by 1. When a negative pulse is received, the Count Register decrements by 1 pulse count. At the end of the demand interval, the EOI input line receives a pulse, and the existing net count is transferred to the Output Register. Once the new interval is started, the normal count pulse counting operation resumes. While this is occurring, the Output Register begins outputting the number of pulses equal to the net count at a rate of 5 pulses per second, or a faster rate, if selected. These are generally fed into an electric meter pulse input, recorder, SCADA system or other telemetry device. If, at the end of a demand interval, the net count is zero or negative, no pulses are outputted to the external device. In this way, the “net” energy represented by the positive pulses minus the negative pulses is derived.

Two Form A (K&Y) solid state isolated, dry-contact outputs are provided. Typical applications include renewable energy application with wind generation or PV solar electric systems requiring interfaces between utility metering devices, demand recorder applications, and supervisory control and data acquisition (SCADA) systems. The NPR-8 provides a sense voltage of +13 VDC to the eight K-Y pulse sending source contacts, normally eight meters, as well as to the EOI pulse input. Each pulse input and the EOI input has a bright LED for system display. An output LED flashing to indicate the pulses being outputted to the external device.

Installation and setup are amazingly simple. Programmable parameters are the pulse sign (positive or negative) and the output pulse width. Non-volatile EEPROM memory “remembers” the Count and Output Register values in the event of power loss. Upon power-up all Register values are restored, so there is no loss of pulse counts or Register values.

The “K” lead of the NPR-8’s outputs are fused to prevent damage to the relay under almost any condition a user might cause such as excessive current, incorrect wiring, etc. The NPR-8 utilizes SSI’s standard built-in transient protection for the solid state relay contacts that eliminates the need for external or off-the-board transient suppressors. All component parts of the NPR-8, which have power applied to them with the exception of the input/output terminal strip, are enclosed in a polycarbonate cover for maximum protection. The mounting base plate is also made of polycarbonate and offers excellent electrical insulation.



REGISTERS/TOTALIZERS

NPR-8 NET METERING REGISTER RELAY

SPECIFICATIONS

ELECTRICAL

Power Input:	120, 208-277 VAC. Burden: 8 mA at 120 VAC
Pulse Input:	Eight 2-Wire Form A inputs. Two "Kin" input terminals are the common return for all meters. The "Yin" terminal is "pulled-up" to +13 VDC making it compatible with open-collector transistors, open-drain FETs or virtually any kind of KYZ switch (i.e. mechanical, electro-mechanical or solid state).
Pulse Output:	Two dry Form A contacts (K & Y). Factory fused at 1/10 Amp with 3AG fuses. Solid state contacts have a maximum output rating of 250VAC/VDC at 1/10 Amp. The maximum power rating of the contacts is 800 MW, without exceeding the maximum voltage and current ratings of the solid state switch.
Output Pulse Rate:	The output pulse rate is selectable between 100mS, 67mS or 33mS with 100 being the default.
Overflow LED:	The Overflow LED indicates that the contents of the output register was too large for the output speed selected and was not able to output all of the contents of the output register before the next end of interval signal was received. This LED is resettable only by the reset function or cycling the power.
Input/Output Isolation Voltage:	2500Vrms
Operate and Release Time:	3 milliseconds max. operate (turn-on) 1 milliseconds max. release (turn off)

MECHANICAL

Mounting:	Any position
Size:	3.50" wide, 7.20" high, 1.50" deep
Weight:	1 pound

TEMPERATURE

Temperature Range:	-38° C to +70° C, -36.4° F to +158° F
Humidity:	0 to 98% non-condensing

AVAILABLE OPTIONS

Input Voltages:	Contact factory for input voltages.
-----------------	-------------------------------------

NPR-8



PULSE LINKS

PRL-2SC WIRELESS PULSE LINK

DESCRIPTION

The PRL-2SC wireless pulse link is a low-cost, single channel point-to-point system with one transmitter and one receiver for short-hop pulse applications. Typically, these are parking lots, fields, roads, railroad tracks or anywhere where it is difficult to get a KYZ pulse from the meter. The PRL-2SC is a self-contained, Form A (2-wire), Line-of-Sight system capable of transmitting pulse information up to about 1 mile depending on topography and particulars of the mounting locations and space in between. Using Frequency Hopping Spread Spectrum (FHSS) technology allows excellent reliability and rejection of any other noise sources. There are 6 selectable channels. Each channel incorporates 50 of the 64 possible frequencies within the 900 MHz band. The same channel is selected on both the transmitter and receiver. Other PRL-2SC systems within the same radio airspace (~2-4 mile radius) will need to be assigned a different channel number. The Transmitter and Receiver are "paired" such that the Receiver will only accept meter pulse data from its specified Transmitter.



The PRL-2SC transmits 1 Form A (2-Wire) pulse in the continuous or real-time operating mode. In continuous mode, transmissions occur continuously about 10 times a second. Approximately 5 pulses per second are possible, which is adequate for most pulse applications. Continuous mode is designed to make the output pulses mirror the input pulse to the greatest extent possible.

The PRL-2SC Wireless Pulse Link system consists of one PRT-2SC Transmitter and one PRR-2SC Receiver. The system operates in the 900MHz band and is FCC pre-certified, thus allowing unlicensed operation by the user. The PRL-2SC will transmit pulses up to 1,000 to feet in a line-of-sight (LOS) configuration. Distances vary with the terrain, obstacles and greater elevation above the ground

FUNCTIONAL SUMMARY

IN	OUT
1	1
2 Wire	2 Wire
A	A

TYPE
FORM

PRL-2SC



PULSE LINKS

PRL-2SC WIRELESS PULSE LINK

SPECIFICATIONS

ELECTRICAL

Power Input:	12-60VDC; 10-48VAC VAC Burden:<10mA at 24 VAC
Input Wetting Voltage to Meter:	+9VDC wetting voltage generated by the PRT-2AC Transmitter unit for use with dry contact compatible meter output.
Output:	One set of dry Form A contacts (“K” & “Y”) for energy pulses. The contacts are solid state “no bounce” relays rated at 250 VDC or 200 VAC 1/10th Amp, 800mW max. Factory fused at 1/10 amp. (3AG)
Output Contact On-State Resistance:	18 ohms typical, 25 ohms maximum
Operate and Release Time:	1 to 3 milliseconds typical for solid state relay; Total propagation time up to 20mS.
Input/Output Isolation Voltage:	2500V
AES Encryption	YES

MECHANICAL

Mounting:	Any position for base units; Must be line of sight for transceiver/antenna units
Size:	4.0” wide, 4.0” high, 2.5” deep
Weight:	2 pounds each

TEMPERATURE

Temperature Range:	-38° C to +70° C, -36.4° F to +158° F
Humidity:	0 to 98% non-condensing

AVAILABLE OPTIONS

Input Voltages:	Contact Factory
Enclosures:	Any NEMA 4X Fiberglass or ABS Enclosure

PRL-2SC



PULSE LINKS

PRL-1600C WIRELESS PULSE LINK

DESCRIPTION

The PRL-1600C SSI's 4th Generation wireless pulse link a point-to-point system with one transmitter and one receiver for short hop pulse applications like parking lots, fields, roads, railroad tracks or anywhere where it is difficult to get a KYZ pulse from the meter. Using Frequency Hopping Spread Spectrum (FHSS) technology allows excellent reliability and rejection of any other noise sources. There are 6 selectable channels. Each channel incorporates 50 of the 64 possible frequencies within the 900 MHz band. The same channel is selected on both the transmitter and receiver. Other PRL-1600C systems within the same radio airspace (~2-4 mile radius) will need to be assigned a different channel number. The transmitter and receiver are paired such that the receiver will only accept meter pulse data from its specified transmitter, and all transmissions use AES encryption.



The PRL-1600C can transmit either 2 Form C (3-wire) pulses or 4 Form A (2-wire) pulses. Transmissions are sent once every 10 seconds with the number of pulses which have been received by the transmitter in the last 10 seconds. The receiver then re-creates the pulses over the next 10 seconds. In this way, pulses are always delayed by 10 seconds, and additional error-checking and transmission acknowledgement are used for high accuracy. The PRL-1600C Wireless Pulse Link system consists of one PRT-1600C transmitter and one PRR-1600C receiver. The system operates in the 900MHz band and is FCC pre-certified, thus allowing unlicensed operation by the user. The PRL-1600C will transmit pulses up to 5,000 to feet in a line-of-sight (LOS) configuration. Distances vary with the terrain, obstacles, and greater elevation above the ground.

PRT-1600C PULSE RADIO TRANSMITTER UNIT

The PRT-1600C Pulse Radio Transmitter unit is made up of two parts: The PRT-16C transmitter base unit and the PRNT-1600C transmitter radio/antenna unit which contains the radio transceiver and the antenna. The PRT-16C Base has a built-in low voltage switching power supply generating a +12VDC sense (wetting) voltage. The sense voltage is connected to pulse sending devices, typically an electric meter's KYZ pulse initiator. Each time a packet is received by the PRNT-1600C, it validates the pulse width and transmits the packet to the receiver. Propagation delay is very short so the pulse output at the receiver closely resembles the pulse widths received from the meter. The PRT-1600C can be operated using 120V to 277V AC line power or a +12VDC voltage source like SSI's SPS-2 solar power supply.

PRR-1600C PULSE RADIO RECEIVER UNIT

The PRR-1600C can be configured as 2 Form C or 4 Form A output channels and acts as the system's receiver. The PRR-1600C consists of a PRR-16C receiver base unit where all connections are made and a PRNR-1600C receiver radio/antenna unit which contains the radio transceiver and antenna. The PRNR-1600C is intended to be mounted outdoors, in direct line-of-sight with the PRNT-1600C transmitter radio/antenna unit and should not be obstructed by trees, buildings or other objects. Each time a packet is received from the PRT-1600C, the receiver validates the packet and outputs its respective pulses. An encoded FHSS communication scheme is used to ensure the accurate number of pulses are sent and received. The PRR-1600C consumes extremely low power and can be operated using 120V to 277V AC line power or a +12VDC voltage source. The pulse rate is up to 4pps (Form C).

*Both the transmitter & receiver units are capable of operating on supply voltages of 120-277VAC, as well as +125VDC, +12VDC, & +15 to +48VDC by employing the special SSI DCS power supply options.

FUNCTIONAL SUMMARY

	IN	OUT
#	4 or 2	4 or 2
TYPE	2 or 3 Wire	2 or 3 Wire
FORM	A or C	A or C

PRL-1600C



PULSE LINKS

PRL-1600C WIRELESS PULSE LINK

SPECIFICATIONS

ELECTRICAL

Power Input:	120-277 VAC Burden: <10 mA at 120 VAC
Input Wetting Voltage to Meter:	+12VDC wetting voltage generated by the PRT-16C Transmitter Base unit.
Output:	Four sets of dry Form A contacts (K & Y) for energy pulses. These can be configured as two sets for dry Form C contacts. The contacts are solid state "no bounce" relays rated at 120 VDC or 120 VAC 1/10th Amp, 800mW max. Factory fused at 1/10 amp. (3AG)
Output Contact On-State Resistance:	18 ohms typical, 25 ohms maximum
Operate and Release Time:	1 to 3 milliseconds typical for solid state relay; Total propagation time up to 20mS.
Input/Output Isolation Voltage:	2500V
AES Encryption	YES

MECHANICAL

Mounting:	Any position for base units; Must be line of sight for transceiver/antenna units
Size:	3.27" wide, 5.7" high, 1.50" deep
Weight:	2 pounds each

TEMPERATURE

Temperature Range:	-38° C to +70° C, -36.4° F to +158° F
Humidity:	0 to 98% non-condensing

AVAILABLE OPTIONS

Input Voltages:	Contact Factory
Enclosures:	10" x 8" x 4" NEMA 4X Fiberglass Enclosure for Base Units 9" x 8" x 3" Low-profile NEMA 4X Polycarbonate Enclosure for Base Units

PRL-1600C



PULSE LINKS

OPL-1B OPTICAL FIBER PULSE LINK

DESCRIPTION

The OPL-1B optical fiber pulse link system is a transmitter/receiver pair that uses fiber optic cable to send metering pulses over long distances. The OPL-1B can receive and transmit pulses over distances up to approximately 3 miles, using multimode fiber or up to 15 miles using the standard single mode fiber cable.

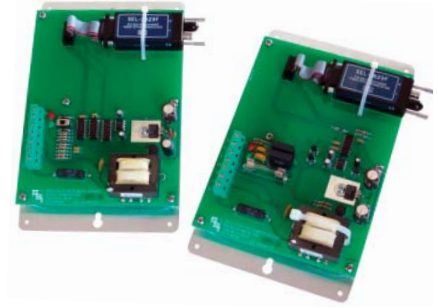

The output is configured as a Form C, but can be used as a Form A (2-wire) or a Form C (3-wire) depending on the transmitter's input configuration selection. This system makes it possible to quickly implement an optical pulse link with minimal effort and includes all power supplies, wetting voltages, isolation relays and connectors.

Each system consists of an OPT-1B transmitter and an OPR-1B receiver. The OPT-1B transmitter is designed to receive pulses from an electric meter's KYZ pulse initiator. Pulses are conditioned and sent by fiber optic cable to an OPR-1B receiver where the pulse information is validated and implemented into the correct pulse state. The OPT-1B transmitter and OPR-1B receiver must be paired and cannot be used independently. Fiber optic cable not included.

Bright red and green LEDs monitor the input status on the OPT-1B transmitter and provide easy and immediate visual system checking without test equipment. A selector switch allows selection of Form A (2-wire) or Form C (3-wire) input configuration.

The OPR-1B receiver also includes bright red LEDs to monitor the K-Y output status. The dry contact output features a 1/4 amp solid-state relay for a no-bounce contact with internal MOV transient suppression circuitry to eliminate contact noise. Rapid pulse rates in excess of 20 pulses per second are possible.

Both the OPT-1B transmitter and OPR-1B receiver come standard mounted on a .062" aluminum base plate with mounting tabs and keyhole mounting slot, intended for mounting in another control equipment enclosure. Each unit weighs approximately 2 pounds and can be mounted in any position. NEMA 4X rain-tight enclosures are available for both the transmitter and receiver units.

The standard OPL-1B is a multi-mode fiber system. A single mode fiber OPL-1B system is available by special order. Contact the factory for current pricing.

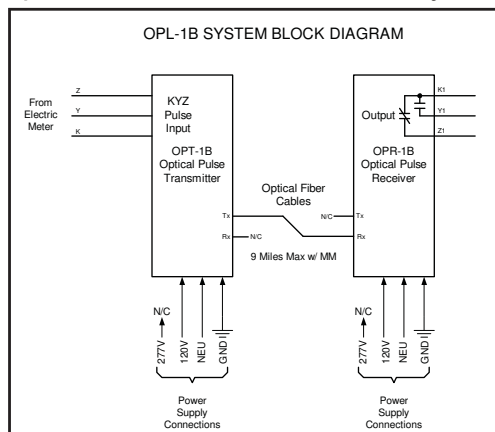

OPL-1B

OPT-1B FUNCTIONAL SUMMARY

	IN	OUT
#	1	1
TYPE	2 or 3 Wire	Optical Fiber
FORM	A or C	-

OPR-1B FUNCTIONAL SUMMARY

	IN	OUT
#	1	1
TYPE	Optical Fiber	2 or 3 Wire
FORM	-	C



PULSE LINKS

OPL-1B OPTICAL FIBER PULSE LINK

SPECIFICATIONS

ELECTRICAL

Power Input:	120, 208-277 VAC. Burden: 3.5 VA
Signal Input:	Optical fiber input from OPT-1B transmitter; One Form C (K,Y, & Z) input from the sending device to the OPT-1B transmitter
Output:	One Form C (K,Y & Z) solid state, dry contact output from the OPR-1B receiver
Maximum Pulse Rate:	OPR-1B: >40 Pulses per second (Form C), 20 pulses per second (Form A) OPT-1B: >200 Pulses per second (Form C), 100 pulses per second (Form A)
Maximum Output Voltage:	250 VAC
Maximum Output Current:	1/4 Amp
Maximum Power Rating:	25 VA
Sense Voltage:	+13VDC provided to the sending device(s)
Contact On-State Resistance:	5 ohms maximum, 3 ohms typical
Switching Time:	Turn On: 8 milliseconds typical Turn Off: 1 milliseconds typical
Input/Output Isolation Voltage:	2500Vrms (of relay alone)

MECHANICAL

Mounting:	Any position.
Size:	5.5" wide, 9.5" high, 3.5" deep
Weight:	2 pounds

TEMPERATURE

Temperature Range:	-38° C to +70° C, -36.4° F to +158° F
Humidity:	0 to 98% non-condensing

AVAILABLE OPTIONS

Input Voltages:	Contact Factory
Enclosure:	NEMA 4X rain-tight and dust-proof enclosure available. 12.0" high, 10.0" wide, 6.0" deep
Fiber:	Long distance single-mode model available by special order

OPL-1B



PULSE LINKS

OPL-1C OPTICAL FIBER PULSE LINK

DESCRIPTION

The OPL-1C optical fiber pulse link system is a transmitter/receiver pair that uses fiber optic cable to send metering pulses over short to medium distances. The OPL-1C can receive and transmit pulses over distances up to approximately 1000 feet using multimode fiber. The output is configured as either one Form C (KYZ), or as a two Form A (KY and KZ) channels depending on the transmitter's operating mode selection. This system makes it possible to quickly implement an optical pulse link with minimal effort and includes all power supplies, wetting voltages, isolation relays and connectors.



Each system consists of an OPT-1C transmitter and an OPR-1C receiver. The OPT-1C transmitter is designed to receive pulses from an electric meter's KYZ pulse initiator. Pulses are conditioned, encoded and sent by fiber optic cable to an OPR-1C receiver where the pulse information is decoded, validated and implemented into the correct pulse state. The OPT-1C transmitter and OPR-1C receiver must be paired and cannot be used independently. Fiber optic cable not included.

Bright red, yellow, and green LEDs monitor the system status on both the transmitter and receiver, and provides an easy and immediate visual system check without test equipment. A mode switch on the OPT-1C allows selection of 2Form A (2-wire) or 1Form C (3-wire) mode configuration.

The OPR-1C receiver also includes bright red and green LEDs to monitor the K-Y and K-Z output status. The dry contact output features a 1/10 amp solid-state relay for a no-bounce contact with internal MOV transient suppression circuitry to eliminate contact noise. Rapid pulse rates in excess of 10 pulses per second are possible.

Both the OPT-1C transmitter and OPR-1C receiver are packaged in the standard SSI large enclosure with mounting tabs, intended for mounting in another control equipment enclosure. Each unit weighs approximately 1 pound and can be mounted in any position. NEMA 4X and 3R rain-tight enclosures are available for both the transmitter and receiver units.

The standard OPL-1C is a multi-mode fiber system. Contact the factory for current pricing.

Applications include IEEE487 compliance for getting KYZ meter pulses from substation meters without copper wire; Longer distance pulse links where copper wire is not available or must be replaced.

INCLUDED IN SYSTEM

OPT-1C Transmitter, OPR-1C Receiver, ordered separately

FUNCTIONAL SUMMARY		
	IN	OUT
#	2/1	2/1
TYPE	2 - 2Wire or 1 - 3 Wire	2 - 2Wire or 1 - 3Wire
FORM	2A or 1C	2A or 1C

OPL-1C



PULSE LINKS

OPL-1C OPTICAL FIBER PULSE LINK

SPECIFICATIONS

ELECTRICAL

Power Input (OPT and OPR):	120, 208-277 VAC. Burden: 2 VA
OPT-1C Signal Input:	One Form C or two Form A (KYZ or KY/KZ) inputs from the sending device (electric meters' pulse outputs)
OPT-1C Output:	Optical Fiber Output to OPR-1C Receiver
OPR-1C Signal Input:	Optical Fiber Input from OPT-1C Transmitter
OPR-1C Output:	One Form C (3-Wire) or two Form A Solid State dry-contact outputs rated at 100mA at 120V, 800mW maximum, fused at .1A
Maximum Pulse Rate:	>10 Pulses per second (Form C), 5 pulses per second (Form A)
OPT-1C Input Debounce Time:	20ms
Sense Voltage:	+13VDC provided to the sending device(s)
Transmission Distance:	Up to 1000 feet using standard multi-mode fiber, depending on using standard multi-mode fiber, depending on fiber quality.
Response Time:	30 mS typical

MECHANICAL

Mounting:	Any position. Mounted on aluminum base plate with mounting tabs and keyhole mounting slots.
Size:	3.1" wide, 7.2" high, 1.5" deep
Weight:	2 pounds

TEMPERATURE

Temperature Range:	-38° C to +70° C, -36.4° F to +158° F
Humidity:	0 to 98% non-condensing

AVAILABLE OPTIONS

Input Voltages:	125VDC with DCS-1; 15-48VDC with DCS-2; contact factory for other voltages
Enclosures:	NEMA 4X raintight and dustproof enclosure available. 12.0" high, 10.0" wide, 6.0" deep NEMA 3R raintight enclosure available. 8" high, 8" wide, 4" deep

OPL-1C



PULSE LINKS

OPL-4B OPTICAL FIBER PULSE LINK

DESCRIPTION

The OPL-4B optical fiber pulse link system is a transmitter/receiver pair designed to send four multiplexed channels of metering pulses over long distances. The OPL-4B can receive and transmit pulses over distances up to 9 miles using multi-mode fiber, or up to 65 miles using single-mode fiber. Transmission distances vary depending on the quality of the fiber.



The OPL-4B system makes it possible to quickly implement a 4-channel optical pulse link with minimal effort. The system includes the power supplies, wetting voltage, isolation relays, and terminal block connectors making it possible to have a multichannel optical link up and running in minutes. The OPL-4B utilizes standard "ST" twist lock connectors and makes connections reliable, quick and easy. The fiber optic cable is not included.

Each OPL system consists of an OPT-4B transmitter and an OPR-4B receiver. The transmitter and receiver are mounted on 5.5"x9.5" panels for assembly in another control enclosure or into an optional NEMA 4X raintight enclosure. The OPT-4B transmitter is designed to receive pulses from electric meters' KYZ pulse initiators. Pulses are conditioned, multiplexed, and sent by fiber to an OPR-4B receiver where the pulse information is validated, de-multiplexed, and implemented into the correct pulse state. Each input can be configured as either Form A (2-wire) or Form C (3-wire). The OPT-4B transmitter requires an OPR-4B receiver of the same fiber type.

Bright red and green LEDs monitor the input status to the OPT-4B transmitter and provide easy & immediate visual system checking without additional test equipment. An incorrect sequence of input pulses will not be recognized and only the first valid pulse of the sequence will be transmitted. While the OPT-4B transmitter is primarily designed for the transmission of metering pulses, it is capable of transmitting any desired Form A or C contact closures such as a relay, switch, breaker status, etc. to an OPR-4B receiver.

The OPR-4B receiver also includes bright red and green LEDs to monitor the KYZ output status. The OPR-4B features a solid-state Form C Contact relay (SPDT) for a no-bounce contact with internal transient suppression circuitry to eliminate contact wear and noise.

MODEL OPTIONS

- OPT-4B-1 Transmitter, OPR-4B-1 Receiver, ordered separately, multi-mode fiber, 3 miles
- OPT-4B-2 Transmitter, OPR-4B-2 Receiver, ordered separately, multi-mode fiber, 9 miles
- OPT-4B-3 Transmitter, OPR-4B-3 Receiver, ordered separately, single-mode fiber, 14 miles
- OPT-4B-4 Transmitter, OPR-4B-4 Receiver, ordered separately, single-mode fiber, 50 miles
- OPT-4B-5 Transmitter, OPR-4B-5 Receiver, ordered separately, single-mode fiber, 65 miles

FUNCTIONAL SUMMARY

	IN	OUT
#	4	4
TYPE	2 or 3 Wire	3 Wire
FORM	A or C	C

OPL-4B



PULSE LINKS

OPL-4B OPTICAL FIBER PULSE LINK

SPECIFICATIONS

ELECTRICAL

Power Input (OPT and OPR):	120, 208-277 VAC. Burden: 4 VA
OPT-4B Signal Input:	Four Form A or C (KYZ & KY) or inputs from the sending device's dry-contact output (electric meters' KYZ outputs)
OPT-4B Output:	Optical Fiber Output to OPR-4B Receiver
OPR-4B Signal Input:	Optical Fiber Input from OPT-4B Transmitter
OPR-4B Output:	Four Form C (3-Wire) Solid State dry-contact outputs rated at 750mA at 250V, 100VA maximum, fused at .5A
Maximum Pulse Rate:	>10 Pulses per second (Form C), 5 pulses per second (Form A)
OPT-4B Input Debounce Time:	20ms
Sense Voltage:	+13VDC provided to the sending device(s)
Transmission Distance:	Approx. 3 to 9 miles using multi-mode fiber; 14 to 65 miles using single-mode fiber, depending on exact model

MECHANICAL

Mounting:	Any position. Mounted on aluminum base plate with mounting tabs and keyhole mounting slots.
Size:	5.5" wide, 9.5" high, 3.5" deep
Weight:	2 pounds

TEMPERATURE

Temperature Range:	-38° C to +70° C, -36.4° F to +158° F
Humidity:	0 to 98% non-condensing

AVAILABLE OPTIONS

Input Voltages:	Contact Factory
Enclosure:	NEMA 4X raintight and dustproof enclosure available. 12.0" high, 10.0" wide, 6.0" deep

OPL-4B



PULSE LINKS

OPL-4C OPTICAL FIBER PULSE LINK

DESCRIPTION

The OPL-4C optical fiber pulse link system is a transmitter/receiver pair designed to send four multiplexed channels of metering pulses over short-to-mid range distances using multi-mode fiber optic cable. The low cost OPL-4C System has a range of approximately 1 mile (1600 meters). Transmission distances vary depending on the quality of the fiber.



FUNCTIONAL SUMMARY

	IN	OUT
#	4	4
TYPE	2 or 3 Wire	3 Wire
FORM	A or C	C

The OPL-4C system makes it possible to quickly implement a 4-channel optical pulse link with minimal effort. The system includes the power supply, wetting voltage, isolation relay and terminal block connectors making it possible to have a multichannel optical link up and running in minutes. The OPL-4C utilizes standard "ST" twist lock connectors and makes connections reliable, quick and easy. The multimode fiber optic cable is not included.

Each OPL system is made up of an OPT-4C transmitter and an OPR-4C receiver. The OPT-4C transmitter is designed to receive pulses from electric meters' KYZ pulse initiators. Pulses are conditioned and sent by fiber to an OPR-4C receiver where the pulse information is validated and implemented into the correct pulse state. Each input can be configured as either Form A (2-wire) or Form C (3-wire). The OPT-4C transmitter requires an OPR-4C receiver.

Bright red and green LEDs monitor the input status to the OPT-4C transmitter and provide easy & immediate visual system checking without additional test equipment. An incorrect sequence of input pulses will not be recognized and only the first valid pulse of the sequence will be transmitted. While the OPT-4C transmitter is primarily designed for the transmission of metering pulses, it is capable of transmitting any desired Form A or C contact closures such as a relay, switch, breaker status, etc. to an OPR-4C receiver.

The OPR-4C receiver also includes bright red and green LEDs to monitor the KYZ output status. The OPR-4C features a solid-state Form C Contact relay (SPDT) for a no-bounce contact with internal transient suppression circuitry to eliminate contact wear and noise.

INCLUDED IN SYSTEM

OPT-4C Transmitter, OPR-4C Receiver, ordered separately.

OPL-4C



PULSE LINKS

OPL-4C OPTICAL FIBER PULSE LINK

SPECIFICATIONS

ELECTRICAL

Power Input (OPT and OPR):	120, 208-277 VAC. Burden: 4 VA
OPT-4C Signal Input:	Four Form A or C (KYZ & KY) or inputs from the sending device (electric meters' KYZ outputs)
OPT-4C Output:	Optical Fiber Output to OPR-4C Receiver
OPR-4C Signal Input:	Optical Fiber Input from OPT-4C Transmitter
OPR-4C Output:	Four Form C (3-Wire) Solid State dry- contact outputs rated at 750mA at 250V, 100VA maximum, fused at .5A
Maximum Pulse Rate:	>10 Pulses per second (Form C), 5 pulses per second (Form A)
OPT-4C Input Debounce Time:	20ms
Sense Voltage:	+13VDC provided to the sending device(s)
Transmission Distance:	Approx. 1 mile, 1600 meters using standard multi-mode fiber

MECHANICAL

Mounting:	Any position. Mounted on aluminum base plate with mounting tabs and keyhole mounting slots.
Size:	5.5" wide, 9.5" high, 3.5" deep
Weight:	2 pounds

TEMPERATURE

Temperature Range:	-38° C to +70° C, -36.4° F to +158° F
Humidity:	0 to 98% non-condensing

AVAILABLE OPTIONS

Input Voltages:	Contact Factory
Enclosure:	NEMA 4X raintight and dustproof enclosure available. 12.0" high, 10.0" wide, 6.0" deep

OPL-4C



PULSE LINKS

OPL-8B OPTICAL FIBER PULSE LINK

DESCRIPTION

The OPL-8B optical fiber pulse link system is a transmitter/receiver pair designed to send eight multiplexed channels of metering pulses over long distances. The OPL-8B can receive and transmit pulses over distances up to 9 miles using multi-mode fiber, or up to 65 miles using single-mode fiber. Transmission distances vary depending on the quality of the fiber.

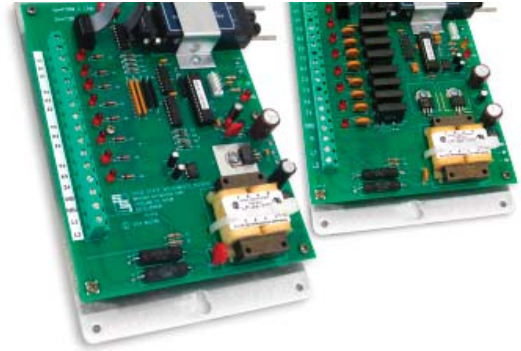

FUNCTIONAL SUMMARY

	IN	OUT
#	8	8
TYPE	2 Wire	2 Wire
FORM	A	A

The OPL-8B system makes it possible to quickly implement an 8-channel optical pulse link with minimal effort. The system includes the power supplies, wetting voltage, isolation relays, and terminal block connectors making it possible to have a multichannel optical link up and running in minutes. The OPL-8B utilizes standard "ST" twist lock connectors and makes connections reliable, quick and easy. The fiber optic cable is not included.

Each OPL system consists of an OPT-8B transmitter and an OPR-8B receiver. The transmitter and receiver are mounted on 5.5"x9.5" panels for assembly in another control enclosure or into an optional NEMA 4X raintight enclosure. The OPT-8B transmitter is designed to receive pulses from electric meters' KYZ pulse initiators. Pulses are conditioned, multiplexed, and sent by fiber to an OPR-8B receiver where the pulse information is validated, de-multiplexed, and implemented into the correct pulse state. Each input is configured as Form A (2-wire). The OPT-8B transmitter requires an OPR-8B receiver of the same fiber type.

Bright red and green LEDs monitor the input status to the OPT-8B transmitter and provide easy & immediate visual system checking without additional test equipment. An incorrect sequence of input pulses will not be recognized and only the first valid pulse of the sequence will be transmitted. While the OPT-8B transmitter is primarily designed for the transmission of metering pulses, it is capable of transmitting any desired Form A contact closures such as a relay, switch, breaker status, etc. to an OPR-8B receiver.

The OPR-8B receiver also includes bright red and green LEDs to monitor the KYZ output status. The OPR-8B features eight solid-state Form A dry-contact output relays (SPST) for a no-bounce contact with internal transient suppression circuitry to eliminate electrical noise and harmful voltage transients.

MODEL OPTIONS

- OPT-8B-1 Transmitter, OPR-4B-1 Receiver, ordered separately, multi-mode fiber, 2.5 miles
- OPT-8B-2 Transmitter, OPR-4B-2 Receiver, ordered separately, multi-mode fiber, 9 miles
- OPT-8B-3 Transmitter, OPR-4B-3 Receiver, ordered separately, single-mode fiber, 14 miles
- OPT-8B-4 Transmitter, OPR-4B-4 Receiver, ordered separately, single-mode fiber, 50 miles
- OPT-8B-5 Transmitter, OPR-4B-5 Receiver, ordered separately, single-mode fiber, 65 miles

OPL-8B



PULSE LINKS

OPL-8B OPTICAL FIBER PULSE LINK

SPECIFICATIONS

ELECTRICAL

Power Input (OPT and OPR):	120, 208-277 VAC. Burden: 4 VA
Signal Input:	Eight Form A (K & Z) inputs from the sending device's dry contact (electric meters' KY output)
Output:	Optical Fiber Output to OPR-8B Receiver
Maximum Pulse Rate:	>10 pulses per second (Form A)
Sense Voltage:	+13VDC provided to the sending device(s)
Transmission Distance:	Approx. 2.5 to 9 miles using multi-mode fiber; 14 to 65 miles using single-mode fiber, depending on exact model

MECHANICAL

Mounting:	Any position. Mounted on aluminum base plate with mounting tabs and keyhole mounting slots.
Size:	5.5" wide, 9.5" high, 3.5" deep
Weight:	2 pounds

TEMPERATURE

Temperature Range:	-38° C to +70° C, -36.4° F to +158° F
Humidity:	0 to 98% non-condensing

AVAILABLE OPTIONS

Input Voltages:	Contact Factory
Enclosure:	NEMA 4X raintight and dustproof enclosure available. 12.0" high, 10.0" wide, 6.0" deep

OPL-8B



PULSE LINKS

OPL-8C OPTICAL FIBER PULSE LINK

DESCRIPTION

The OPL-8C optical fiber pulse link system is a transmitter/receiver pair designed to send eight multiplexed channels of metering pulses over short-to-mid range distances using multi-mode fiber optic cable. The low cost OPL-8C system has a range of approximately 1 mile (1600 meters). Transmission distances vary depending on the quality of the fiber.

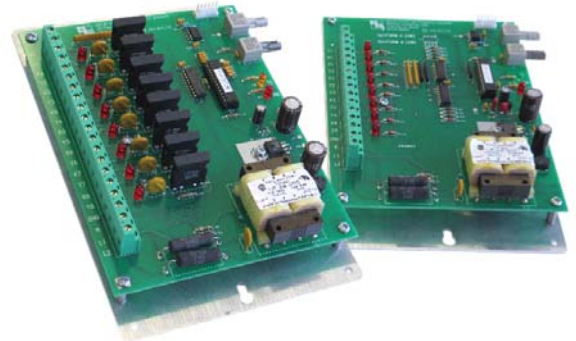

FUNCTIONAL SUMMARY

	IN	OUT
#	8	8
TYPE	2 Wire	2 Wire
FORM	A	A

The OPL-8C system makes it possible to quickly implement an 8-channel optical pulse link with minimal effort. The system includes the power supply, wetting voltage, isolation relay and terminal block connectors making it possible to have a multichannel optical link up and running in minutes. The OPL-8C utilizes standard "ST" twist lock connectors and makes connections reliable, quick and easy. The multimode fiber optic cable is not included.

Each OPL-8C system is made up of an OPT-8C transmitter and an OPR-8C receiver. The OPT-8C transmitter is designed to receive pulses from the electric meters' K-Y pulse initiators. Pulses are conditioned and sent by fiber to an OPR-8C receiver where the pulse information is de-multiplexed, validated and implemented into the correct pulse state. The inputs are configured as Form A (2-wire) channels. The OPT-8C transmitter requires an OPR-8C receiver.

Bright red LEDs monitor the input status to the OPT-8C transmitter and provide easy & immediate visual system checking without additional test equipment. The inputs are debounced such that pulses with less than the minimum width timing are not be recognized, and only valid pulses are transmitted. While the OPT-8C transmitter is primarily designed for the transmission of metering pulses, it is capable of transmitting any desired Form A contact closure such as a relay, switch, breaker status, etc. to an OPR-8C receiver.

The OPR-8C receiver also includes bright red LEDs to monitor the K-Y output status. The OPR-8C features a solid-state Form A Contact relay (SPST) for a no-bounce contact with internal transient suppression circuitry to eliminate contact wear and noise. The Receiver uses SSI's heavy duty solid state relay rated at 750mA at 800V for maximum pulse switching capability in most any application.

INCLUDED IN SYSTEM

OPT-8C Transmitter, OPR-8C Receiver, ordered separately.

OPL-8C



PULSE LINKS

OPL-8C OPTICAL FIBER PULSE LINK

SPECIFICATIONS

ELECTRICAL

Power Input:	120, 208-277 VAC. Burden: 5 VA
Signal Input:	Eight Form A (K & Z) inputs from the sending device (electric meters' KY output)
Output:	Optical Fiber Output to OPR-8C Receiver
Maximum Pulse Rate:	>50 Pulses per second (Form C), 25 pulses per second (Form A)
Sense Voltage:	+13VDC provided to the sending device(s)
Transmission Distance:	Approx. 1 mile (1600 meters) using standard multi-mode fiber

MECHANICAL

Mounting:	Any position. Mounted on aluminum base plate with mounting tabs and keyhole mounting slots.
Size:	5.5" wide, 9.5" high, 3.5" deep
Weight:	2 pounds

TEMPERATURE

Temperature Range:	-38° C to +70° C, -36.4° F to +158° F
Humidity:	0 to 98% non-condensing

AVAILABLE OPTIONS

Input Voltages:	Contact Factory
Enclosure:	NEMA 4X raintight and dustproof enclosure available. 12.0" high, 10.0" wide, 6.0" deep

OPL-8C



PULSE LINKS

PTR-1PS PULSE TRANSMITTING RELAY

DESCRIPTION

The PTR-1PS pulse transmitting relay is designed to transmit KYZ pulses over long distances up to approximately 4 miles. It provides a 2-wire current loop output and must be connected to a CLR-1, CLR-2 or CLR-3 to receive the pulses. These units are a functional replacement for the GE DC-1 Power Supply and S-4 Relay, or other older devices used for long distance pulse transmission.



FUNCTIONAL SUMMARY

	IN	OUT
#	1	1
TYPE	3 Wire	CL
FORM	C	CL

The PTR-1PS contains a 3-Wire Form C input (K, Y, & Z). A +9VDC sense voltage is sent from the K input terminal to the pulse-sending device, typically an electric meter, and returns to the PTR-1PS from the Y and Z outputs of the meter. Each time the input changes state, the polarity of the current loop is reversed causing the CLR receiving relay at the remote end of the cable to switch to the opposite state. Wire size in the current loop is not critical but longer distances may be obtained with larger gauge wire.

The PTR-1PS has a built-in low voltage transformer isolated powered power supply and may be used with meters having mechanical output contacts (relays), or high or low voltage semiconductor outputs.

Typical applications include interfaces between utility metering devices and customer-owned energy control systems, demand recorder applications, and supervisory control systems (SCADA) interfaces. The PTR-1PS relay contains circuitry designed to prevent false outputs from occurring. An incorrect sequence of input pulses is detected and only the first valid pulse will result in an output.

Bright red and green LED lamps indicate the system's status at all times thus allowing a rapid check of the system's performance without requiring any additional test equipment. The PTR-1PS's input and output circuit's terminal strip is a "EURO" type connector. When the stripped wire has been correctly installed in the terminals "slot" no conductive parts are exposed on the surface of the terminal strip. Due to the inherent current-limited nature of the design, no fusing is necessary on the output. No damage will result if the current loop is shorted.

The PTR-1PS has built-in MOV transient protection for the solid-state relay contacts as well as for the current loop, eliminating the need for external surge suppression. All component parts that have power applied to them, with the exception of the input/output terminal strip are enclosed in a polycarbonate cover for maximum protection. The mounting base plate is also made of polycarbonate and offers excellent electrical insulation between the circuit and the mounting surface. The PTR-1PS is designed to mount in a suitable electrical enclosure for the application.

PTR-1PS



PULSE LINKS

PTR-1PS PULSE TRANSMITTING RELAY

SPECIFICATIONS

ELECTRICAL

Power Input:	90 to 300 VAC. Burden: 10 mA at 120 VAC
Output:	Current loop output for CLR Series relays. Factory fused at 1/2 amp. (3AG)
Contact On-State Resistance:	5 ohms maximum, 3.4 Ohms typical
Operate and Release Time:	Turn-On: 5 milliseconds maximum Turn-Off: 3 milliseconds maximum
Input/Output Isolation Voltage:	2500Vrms

MECHANICAL

Mounting:	Any position
Size:	3.5" wide, 7.2" high, 1.5" deep
Weight:	17 ounces

TEMPERATURE

Temperature Range:	-38° C to +70° C, -36.4° F to +158° F
Humidity:	0 to 98% non-condensing

AVAILABLE OPTIONS

Input Voltages:	125 VDC input using the DSC-1 Power Supply. Contact factory for other input voltages.
-----------------	---

PTR-1PS



PULSE LINKS

PTR-2PS PULSE TRANSCEIVING RELAY

DESCRIPTION

The PTR-2PS is a specialized pulse isolation and repeating relay system designed to receive pulses over long distances (up to approximately 2 miles) and protect customer equipment. It utilizes a 2-wire current loop to source a nominal +12VDC wetting voltage to the electric meter's dry contact output. It receives the switched voltage back to activate the PTR-2PS' output relays. The PTR-2PS is available in 1, 2, and 3 Form A outputs (K & Y). Its current loop design will adjust the output voltage to overcome and compensate for the resistance of the wire loop.



FUNCTIONAL SUMMARY

	IN	OUT
#	1	3
TYPE	2 Wire	2 Wire
FORM	A	A

TYPE
FORM

PTR-2PS

The PTR-2PS is intended to be located at the location of the receiving equipment – usually a customer-owned energy management system. It acts primarily to protect the customer equipment from large transients that could be coupled into long wire runs between it and the electric meter. Transients which are coupled into the wire loop between the originating pulse output and the receiving relay are contained within the loop and suppressed by means of heavy duty transient suppression devices.

Each time the pulse output closes, the current loop sends sufficient current though the wire loop so as to receive back the required current to activate the relay outputs. If the resistance of the wire loop is high, the PTR-2PS will automatically raise the wetting voltage until the optimum current is received back. In this manner, wire length and size in the current loop are not critical. Longer distances may be obtained with larger gauge wire.

The PTR-2PS has a built-in low voltage transformer-isolated power supply and may be used with meters having high or low voltage semiconductor outputs, or mechanical output contacts (relays). Typical applications include interfaces between utility metering devices and customer-owned energy control systems. A bright red LED lamp indicates the system's status at all times, thus allowing a rapid check of the system's performance without requiring any additional test equipment. The PTR-2PS's input and output circuit's terminal strip is a "EURO" type connector. When the stripped wire has been correctly installed in the terminal "slot" there are no conductive parts exposed on the surface of the terminal strip. Due to the inherent current-limited nature of the design, no fusing is necessary on the input. No damage will result if the current loop is shorted to itself or to ground.

The PTR-2PS has built-in MOV transient protection for the three solid-state relay outputs as well as for the current loop, eliminating the need for external surge suppression. In addition, each of the three solid-state outputs have fusing with standard 3AG or AGC fuses. All component parts that have power applied to them, with the exception of the input/output terminal strip, are enclosed in a polycarbonate cover for maximum protection. The mounting base plate is also made of polycarbonate and offers excellent electrical insulation between the circuit and the mounting surface. The PTR-2PS is designed to mount in a suitable electrical enclosure for the application.



PULSE LINKS

PTR-2PS PULSE TRANSCEIVING RELAY

SPECIFICATIONS

ELECTRICAL

Power Input:	90 to 300 VAC. Burden: 12.4 mA at 120 VAC
Signal Input:	Current loop 20mA at +8 to +15VDC
Outputs:	Three solid-state relays rated at 500 mA at 250V. Factory fused at 1/2 amp. (3AG or AGC)
Output Contact On-State Resistance:	2.3 ohms maximum, 1.7 Ohms typical
Operate and Release Time:	Turn-On: 20 milliseconds maximum, 8mS typical Turn-Off: 5 milliseconds maximum, 1mS typical
Input/Output Isolation Voltage:	2500Vrms

MECHANICAL

Mounting:	Any position
Size:	3.5" wide, 7.2" high, 1.5" deep
Weight:	17 ounces

TEMPERATURE

Temperature Range:	-38° C to +70° C, -36.4° F to +158° F
Humidity:	0 to 98% non-condensing

AVAILABLE OPTIONS

Input Voltages:	125 VDC input using the DCS-1 Power Supply. 15-48VDC input using the DCS-2 Power Supply. Contact factory for other input voltages.
-----------------	--

MODELS

PTR-2PS-1	1 output
PTR-2PS-2	2 outputs
PTR-2PS-3	3 outputs

PTR-2PS



PULSE LINKS

CLR SERIES CURRENT LOOP RELAYS

DESCRIPTION

The CLR Series of Current Loop Receiving relays is designed to receive KYZ pulse information from the PTR-1PS Pulse Transmitting Relay over a twisted pair current loop. Since the CLR Series is powered by and operated from the PTR-1PS's current loop output, it needs no separate power supply. The CLR Series is available with one to three outputs. Each output is an isolated solid-state Form C (K, Y, & Z) relay contact.



Applications include long distance pulse transmission interfaces up to 2-4 miles between utility metering devices and customer-owned energy control systems, demand recorders, or supervisory control (SCADA) systems.

The CLR Series relays contain high light output red and green LED indicators that display the system's status at all times thus allowing a rapid check of the metering system's pulse pick-up and relay's performance without requiring any additional test equipment.

The CLR Series' input and output circuit's terminal strip is a "Euro" type connector. When the stripped wire has been correctly installed in the terminal's slot, no conductive parts are exposed on the surface of the terminal strip. Due to the inherent current-limited nature of the design, no fusing is necessary on the input. No damage will result if the current loop is shorted.

The "K" lead of each of the CLR relay's outputs is fused to prevent damage to the relay under almost any conditions a user might encounter such as excessive current, incorrect wiring, etc. The CLR's output relays have built-in MOV transient protection for the solid-state relay contacts. Transient suppression for the current loop is provided by metal-oxide varistors (MOV's) between the current loop input terminals and ground. This eliminates the need for external or off-the-board transient suppressors. All component parts which have voltage applied to them, with the exception of the input-output terminal strip, are enclosed in a polycarbonate cover for maximum user protection. The mounting base plate is also made of polycarbonate and offers excellent electrical insulation between the circuit and the mounting surface. The CLR series relays are designed to mount inside another enclosure, suitable for the user's intended application.

AVAILABLE MODELS

- CLR-1PS - One Form C output (up to 4 miles* from the PTR-1PS)
 - CLR-2PS - Two Form C outputs (up to 3 miles* from the PTR-1PS)
 - CLR-3PS - Three Form C outputs (up to 2 miles* from the PTR-1PS)
- (* Actual distance depending on wire gauge used.)

FUNCTIONAL SUMMARY

	IN	OUT
#	1	1, 2 or 3
TYPE	CL	3 Wire
FORM	CL	C

CLR-SERIES



CLR-SERIES

PULSE LINKS

CLR SERIES CURRENT LOOP RELAYS

SPECIFICATIONS

ELECTRICAL

Power Input:	No separate power supply required; powered by current loop. Ground connection to earth (electrical system) ground only
Contact On-State Resistance:	5 Ohms Typical max, 3.4 ohms typical
Insulation Resistance:	50 megohms typical
Operate and Release Time:	Turn On Time - 8 mS typical; 20 mS MAX Turn Off Time - 1 mS typical; 5 mS MAX
Input/Output Isolation Voltage:	2500Vrms

MECHANICAL

Mounting:	Any position
Size:	3.5" wide, 7.2" high, 1.5" deep
Weight:	10 - 12 ounces

TEMPERATURE

Temperature Range:	-38° C to +70° C, -36.4° F to +158° F
Humidity:	0 to 98% non-condensing



SSI STANDARD

PPG-1 PROGRAMMABLE PULSE GENERATOR

DESCRIPTION

The PPG-1 is a programmable microcontroller-based, high-speed Pulse Generator designed to provide two independent “dry” 2-wire Form A contacts (KY) outputs at a programmable pulse rate and pattern. The PPG-1 features three pulse output modes making it fast and easy to model most pulse scenarios desired. Programmable On and Off times may be set with on and off times between 50 microseconds* and 100,00 milliseconds (10 seconds).



The PPG-1 has three modes of operation, Continuous, One-Time and Interval modes. In the Continuous pulse mode, the PPG-1 will continuously generate pulses of a desired width and spacing until such time that the continuous output is terminated. In the One-Time mode, a single sequence of one or more pulses is outputted of a desired width and spacing when triggered. In the Interval mode, a desired number of pulses with specified pulse widths and spacing is outputted, with an interval spacing time before the sequence repeats. It will continuously repeat until the sequence is terminated. All settings are programmable using a PC with a terminal program such as Tera Term or Puddy using the PPG-1’s USB interface. On and Off times are programmable in all three modes.

Output Channels 1 and 2 operate independently. They may be set and operated for different modes and different pulse widths and interval lengths. All settings are stored in non-volatile EEPROM memory. Upon power-up, all system settings are restored and operation resumed.

If the number of output pulses exceeds the timing constraints of the pulse on times and off times, the microcontroller will notify the user that that scenario is not possible to execute.

The PPG-1 utilizes bright red and green LED lamps to indicate the output status, communication status allowing a rapid visual check-out of the system’s performance without requiring any additional test equipment.

The PPG-1 is be programmed using a USB A-B Programming cable with a terminal program, like TeraTerm, Puddy or HyperTerminal.

The input and output circuits’ terminal strip are “Euro” type connectors. The K leads of each of the PPG-1’s isolated outputs are fused to prevent damage to the relays under almost any condition a user might subject it to, such as excessive current, voltage, or incorrect wiring. The K terminal is system ground allowing the use of standard electro-mechanical, dry contact switches or solid-state open-collector transistor or MOS-FET pulse initiators. The PPG-1 has built-in MOV transient protection for the solid-state relay contacts that eliminates the need for external or off-the-board transient suppressors. All component parts of the PPG-1, which have power applied to them with the exception of the input/output terminal strips and the USB programming port connector, are enclosed in a polycarbonate cover for maximum user protection. The mounting base is also made of polycarbonate and offers excellent electrical insulation. Mounting tabs on the base plate allow the PPG-1 to be mounted in an appropriate enclosure for the application and the operating environment.

PPG-1

#	OUT
	2
TYPE	2 Wire
FORM	A



SSI STANDARD

PPG-1 PROGRAMMABLE PULSE GENERATOR

SPECIFICATIONS

ELECTRICAL

Electrical Power Input:	120 VAC, 208-277 VAC; Burden: 10 mA at 120 VAC
Pulse Output:	Two sets of dry Form "A" contacts (K & Y). Contacts are solid-state relays rated at 250VAC/VDC, 100 mA MAX. The maximum power dissipation rating of the contacts is 800 mW. Factory fused at 1/10 amp. (3AG)
Contact Resistance:	25 ohms maximum, 18 ohms typical
Operate and Release Time:	1 milliseconds max. operate (turn-on) 1 milliseconds max. release (turn off)
Input/Output Isolation Voltage:	3500Vrms

MECHANICAL

Mounting:	Any position.
Size:	3.50" wide, 7.20" high, 1.50" deep
Weight:	1 pound

TEMPERATURE

Temperature Range:	-38° C to +70° C, -38.4° F to +158° F
Humidity:	0 to 98% non-condensing

AVAILABLE OPTIONS

Input Voltages:	12VDC, 24VAC/VDC, 15-48VDC, 125VDC; For others contact factory
Enclosure:	NEMA 3R or 4X

PPG-1



SPECIALTY DEVICES

WPG-1 WIRELESS PULSE GENERATOR

DESCRIPTION

The WPG-1 wireless meter pulse generator integrates ITRON's Gen 5 Riva advanced meter with legacy KYZ pulse metering. Using Wifi radio technology, the WPG-1 receives usage data from the meter's Wifi interface, interprets power usage, and converts it into KYZ pulses. With the WPG-1, pulses are synthesized without having an actual KYZ output at the meter. By doing this, the utility can implement the new advanced AMI meters and still provide pulses to customers that may need them.

The WPG-1 incorporates a Wifi module and two KYZ pulse outputs. As the WPG-1 receives periodic data from utility's meter, the data is read and interpreted to obtain the current demand and energy information. Accumulated energy is computed and pulses are outputted according to a selected pulse type and value.



FUNCTIONAL SUMMARY

	IN	OUT
#	1	2
TYPE	Wifi interface with Meter	2 Wire or 3 Wire
FORM	---	A or C

WPG-1

All system settings are accomplished through a USB programming port that provides for pulse type, pulse value, meter multiplier, output mode, and pulse timing. The output is selectable as either Form A (2-Wire) or Form C (3-Wire) and operates in either the momentary or toggle mode, respectively. The momentary mode has six pulse width time settings: 25mS, 50mS, 100mS, 200mS or 500mS and 1000mS. The toggle mode toggles back and forth to the opposite state upon each new pulse being generated which emulates the classic KYZ pulse output. There are four LED's, one red and one green for each output, which show pulse output status.

The output pulse value is selectable from 1 to 99999 watt-hours per pulse. A meter multiplier of 1 to 99999 may be programmed into the WPG-1 using the SSI Universal Programmer software. A 30mS fixed minimum-off time delay prevents pulses from occurring too rapidly. Bright red, yellow and green LEDs monitor the system communications status and provide an easy and immediate visual system check without test equipment.

The Wifi module must first be paired with the meter, a process that is performed by the participating utility. Once paired with the meter, the module will begin receiving information from the meter and generating pulses.

The WPG-1 is compatible with Self-Contained or Instrument-rated electric meters that are equipped with a Wifi interface. The WPG-1's USB programming port is used to enter the specific site's meter multiplier from 1 to 99999. Each output of the WPG-1 can be configured to generate kWh, kVAh or kVARh pulses in either delivered (positive or forward) or received (negative or reverse) quantities.



SPECIALTY DEVICES

WPG-1 WIRELESS PULSE GENERATOR

SPECIFICATIONS

ELECTRICAL

Power Input:	120, 208-277 VAC. Burden: 10 VA
Input:	Wifi From ITRON Gen 5 Riva
Output:	Two Form A (2-Wire) or Form C (3-wire) Solid State dry-contact outputs rated at 100mA at 120V, 800mW maximum, fused at .1A
Maximum Pulse Output Rate:	≈15 Pulses per second (Form C) ≈10 pulses per second (Form A) *50 mS or less
Minimum Time between Output Pulses:	30ms
Form A Pulse Width:	25, 50, 100, 200, 500, 1000 mS
Output Pulse Values:	1-99999 Wh/pulse, VAh/Pulse or VARh/Pulse

MECHANICAL

Mounting:	Any position
Size:	3.1" wide, 7.2" high, 1.5" deep
Weight:	1 pound

TEMPERATURE

Temperature Range:	-38° C to +70° C, -38.4° F to +158° F
Humidity:	0 to 98% non-condensing

AVAILABLE OPTIONS

Input Voltages:	Contact factory
Enclosures:	NEMA 4X lockable raintight and dustproof enclosure available. 10.0" high, 8.0" wide, 4.0" deep, includes mounting plate

WPG-1



SPECIALTY DEVICES

WPG-1E WIRELESS PULSE GENERATOR

DESCRIPTION

The WPG-1E Wireless Meter Pulse Generator is identical to the WPG-1 but features an 9" x 8" x 3" NEMA 4X enclosure for direct outdoor mounting. Like the WPG-1, the WPG-1E uses periodically received data from a Wi-Fi enabled electric meter to interpret power usage and generate KYZ pulses.



FUNCTIONAL SUMMARY

	IN	OUT
#	1	2
TYPE	Wifi interface with Meter	2 Wire or 3 Wire
FORM	---	A or C

WPG-1E features programmable pulse outputs enabling kWh, kVAh or kVARh pulses for both delivered and received quantities. Configuring the WPG-1E is fast and easy using the SSI Universal Programmer software, available on the Solid State Instruments website as a free download.

The WPG-1E incorporates a Wi-Fi radio module and two independent KYZ pulse outputs. As the WPG-1E receives periodic data from utility's meter, the data is read and interpreted to obtain the current demand and energy information. Accumulated energy quantities are computed, and pulses are outputted according to a selected pulse type and value.

All system settings are accomplished through a USB programming port that provides for pulse type, pulse value, meter multiplier, output mode, and pulse timing. The outputs are individually configurable as Form A (2-Wire) or Form C (3-Wire) and can operate in either the momentary or toggle mode, respectively. The momentary mode has six pulse width time settings: 25mS, 50mS, 100mS, 200mS or 500mS and 1000mS. The toggle mode toggles back and forth to the opposite state upon each new pulse being generated, emulating the classic KYZ Pulse output. There are four LED's show the pulse output status.

The output pulse value is selectable from 1 to 99999 watt-hours, va-hours or var-hours per pulse. Each of the two outputs may be set independently for type and value of the pulse. A meter multiplier of 1 to 99999 may be programmed into the WPG-1 using the SSI Universal Programmer software. A 30mS fixed minimum-off time delay prevents pulses from occurring too rapidly. Bright red, yellow and green LEDs monitor the system communications status and provide an easy and immediate visual system check without test equipment.

The WPG-1E's Wi-Fi module must first be paired with the meter, a process generally performed by the participating utility supplying the meter. Once paired, the WPG-1E's Wi-Fi module will begin receiving information from the meter and generating pulses. The WPG-1E is compatible with Self-Contained or Instrument-rated electric meters. The WPG-1E's USB programming port is used to enter the specific site's meter multiplier from 1 to 99999.

WPG-1E



SPECIALTY DEVICES

WPG-1E WIRELESS PULSE GENERATOR

SPECIFICATIONS

ELECTRICAL

Power Input:	120-277 VAC Autoranging; Burden: 10 VA typical
Input:	Wi-Fi From Wi-Fi Compatible Meter (ITRON Gen5 Riva)
Output:	Two Form A (2-Wire) or Form C (3-wire) Solid State dry-contact outputs rated at 100mA at 120V, 800mW maximum, fused at .1A
Maximum Pulse Output Rate:	≈15 Pulses per second (Form C) ≈10 pulses per second (Form A) *50 mS or less
Minimum Time between Output Pulses:	30ms
Form A Pulse Width:	25, 50, 100, 200, 500, 1000 mS
Output Pulse Values:	1-99999 Wh/pulse, VAh/Pulse or VARh/Pulse

MECHANICAL

Mounting:	Any position
Size:	8" wide, 9" high, 3" deep
Weight:	2 pounds

TEMPERATURE

Temperature Range:	-38° C to +70° C, -38.4° F to +158° F
Humidity:	0 to 98% non-condensing

AVAILABLE OPTIONS

Input Voltages:	Contact factory
-----------------	-----------------

WPG-1E



SPECIALTY DEVICES

WPG-1SC WIRELESS METER PULSE GENERATOR

DESCRIPTION

The WPG-1SC Wireless Meter Pulse Generator is SSI's wireless Pulse Link to the ITRON Gen5/Riva meter. It integrates AMI smart meter technology with legacy KYZ pulse metering. Using a dedicated WiFi network, the WPG-1SC receives usage data from the Riva's HAN network, interprets power usage, and converts it into KYZ pulses. With the WPG-1SC, pulses are synthesized without having an actual KYZ output in the meter. By using the WPG-1SC, utilities can implement the new advanced AMI meters and still provide pulses to customers that may need them.



The WPG-1SC features integral Wifi radio module and two KYZ pulse outputs, in a polycarbonate NEMA 4X enclosure. As the WPG-1SC receives periodic data from utility's meter, the data is read and interpreted to obtain the current demand information. Accumulated energy is computed, and pulses are outputted according to a selected pulse value.

All system settings are accomplished through a USB programming port that provides for pulse value, meter multiplier, output mode, and pulse timing. The output is selectable as either Form A (2-Wire) or Form C (3-Wire) and operates in either the momentary or toggle mode, respectively. The momentary mode has six pulse width time settings: 25mS, 50mS, 100mS, 200mS or 500mS and 1000mS. The toggle mode toggles back and forth to the opposite state upon each new pulse being generated. There are two LED's, one red and one green, which show pulse output status.

The output pulse value is selectable from 1 to 99999 watt-hours per pulse. A meter multiplier of 1 to 99999 may be programmed into the WPG-1SC using the SSI Universal Programmer software.

A 30mS fixed minimum-off time delay prevents pulses from occurring too rapidly. Bright red, yellow and green LEDs monitor the system communications status and provide an easy and immediate visual system check without test equipment.

The WiFi module must be paired or "provisioned" with the AMI meter with the Meter's HAN network radio, a process that is performed by the participating utility or on the utility's website. Once paired with the meter, the WPG-1SC will begin receiving information from the meter and generating pulses.

The WPG-1SC is compatible with Self-Contained or Instrument-rated electric meters. The WPG-1SC's USB programming port is used to enter the specified site's meter multiplier from 1 to 99999. In addition, the WPG-1SC can be configured for Normal mode (kWh delivered only) for unidirectional energy flow, or for Signed mode (kWh delivered and received) for bi-directional energy flow. The WPG-1 also supports End-Of-Interval capability with a Form A (2-wire) output for intervals over a wide range.

FUNCTIONAL SUMMARY

	IN	OUT
#	1	2+1
TYPE	WIFI	2 Wire or 3 Wire
FORM	---	2 A or C, 1 A for EOI

WPG-1SC

SOLID STATE INSTRUMENTS A Product Family Owned by RADIAN RESEARCH

3852 Fortune Dr. • Lafayette, IN • Ph: 765-449-5500 • Fax: 765-448-4614

www.radianresearch.com



SPECIALTY DEVICES

WPG-1SC WIRELESS METER PULSE GENERATOR

SPECIFICATIONS

ELECTRICAL

Power Input:	120-277 VAC. Burden: ~12 VA
Input:	Wifi HAN Network with Riva meter
Output:	Two Form A (2-Wire) or Form C (3-wire) Solid State dry-contact outputs rated at 100mA at 120V, 800mW maximum, fused at .1A; One Form A (2-Wire) Solid State
Maximum Pulse Output Rate:	≈15 Pulses per second (Form C) ≈10 pulses per second (Form A)
Minimum Time between Output Pulses:	30ms
Form A Pulse Width:	25, 50, 100, 200, 500, 1000 mS
Output Pulse Values:	1-99999 Wh/pulse
End of Interval Output:	1 Form A (2-wire) output for EOI
Interval Lengths:	1, 5, 10, 15, 30, 60 minutes
Interval Pulse Widths:	50, 100, 250, 500, 1000, 2000, 5000, 10000mS

MECHANICAL

Mounting:	Any position
Enclosure Type:	NEMA 4X Weatherproof and Dustproof
Size:	9.5" wide, 11.5" high, 4.5" deep
Weight:	8 pounds

TEMPERATURE

Temperature Range:	-40° C to +70° C, -40° F to +158° F
Humidity:	0 to 98% non-condensing

AVAILABLE OPTIONS

Input Voltages:	Contact factory
-----------------	-----------------

WPG-1SC

MPG-3 WIRELESS PULSE GENERATOR

DESCRIPTION

The MPG-3 Wireless Meter Pulse Generator is SSI's third generation Zigbee Pulse Generator. It integrates AMI smart meters with legacy KYZ pulse metering. Using Zigbee® radio technology, the MPG-3 receives usage data from the meter's HAN network, interprets power usage, and converts it into KYZ pulses. With the MPG-3, pulses are synthesized without having an actual KYZ output in the meter. By using the MPG-3, utilities can implement the new advanced AMI meters and still provide pulses to customers that may need them.



FUNCTIONAL SUMMARY

	IN	OUT
#	1	2
TYPE	USB Zigbee® Radio Module	2 Wire or 3 Wire
FORM	---	A or C

The MPG-3 features integral Zigbee radio module and two KYZ pulse outputs. As the MPG-3 receives periodic data from utility's meter, the data is read and interpreted to obtain the current demand information. Accumulated energy is computed, and pulses are outputted according to a selected pulse value. All system settings are accomplished through a USB programming port that provides for pulse value, meter multiplier, output mode, and pulse timing. The output is selectable as either Form A (2-Wire) or Form C (3-Wire) and operates in either the momentary or toggle mode, respectively. The momentary mode has six pulse width time settings: 25mS, 50mS, 100mS, 200mS or 500mS and 1000mS. The toggle mode toggles back and forth to the opposite state upon each new pulse being generated. There are two LED's, one red and one green, which show pulse output status.

The output pulse value is selectable from 1 to 99999 watt-hours per pulse. A meter multiplier of 1 to 99999 may be programmed into the MPG-3 using the SSI Universal Programmer software.

A 30mS fixed minimum-off time delay prevents pulses from occurring too rapidly. Bright red, yellow and green LEDs monitor the system communications status and provide an easy and immediate visual system check without test equipment.

The Zigbee module must be paired or "provisioned" with the AMI meter with a HAN network radio, a process that is performed by the participating utility or on the utility's website. Once paired with the meter, the MPG-3 will begin receiving information from the meter and generating pulses.

The MPG-3 is compatible with Self-Contained or Instrument-rated electric meters. The MPG-3's USB programming port is used to enter the specific site's meter multiplier from 1 to 99999. In addition, the MPG-3 can be configured for Normal mode (kWh delivered only) for unidirectional energy flow, or for Signed mode (kWh delivered and received) for bi-directional energy flow.

MPG-3



SPECIALTY DEVICES

MPG-3 WIRELESS PULSE GENERATOR

SPECIFICATIONS

ELECTRICAL

Power Input:	120, 208-277 VAC. Burden: 10 VA
Input:	Zigbee HAN Network with AMI meter
Output:	Two Form A (2-Wire) or Form C (3-wire) Solid State dry-contact outputs rated at 100mA at 120V, 800mW maximum, fused at .1A
Maximum Pulse Output Rate:	≈15 Pulses per second (Form C) ≈10 pulses per second (Form A)
Minimum Time between Output Pulses:	30ms
Form A Pulse Width:	25, 50, 100, 200, 500, 1000 mS
Output Pulse Values:	1-99999 Wh/pulse

MECHANICAL

Mounting:	Any position
Size:	3.1" wide, 7.2" high, 1.5" deep
Weight:	1 pound

TEMPERATURE

Temperature Range:	-38° C to +70° C, -36.4° F to +158° F
Humidity:	0 to 98% non-condensing

AVAILABLE OPTIONS

Input Voltages:	Contact factory
Enclosures:	NEMA 4X fiberglass raintight and dustproof enclosure available. 10.0" high, 8.0" wide, 4.0" deep, includes mounting plate

MPG-3



SPECIALTY DEVICES

MPG-3E WIRELESS PULSE GENERATOR

DESCRIPTION

The MPG-3E Wireless Meter Pulse Generator is SSI's third generation Zigbee Pulse Generator housed in a NEMA 4X enclosure. It integrates AMI smart meters with legacy KYZ pulse metering. Using Zigbee® radio technology, the MPG-3E receives usage data from the meter's HAN network, interprets power usage, and converts it into KYZ pulses. With the MPG-3E, pulses are synthesized without having an actual KYZ output in the meter. By using the MPG-3E, utilities can implement the new advanced AMI meters and still provide pulses to customers that may need them.



FUNCTIONAL SUMMARY

	IN	OUT
#	1	2
TYPE	USB Zigbee® Radio Module	2 Wire or 3 Wire
FORM	---	A or C

MPG-3E

The MPG-3E features integral Zigbee radio module and two KYZ pulse outputs. As the MPG-3E receives periodic data from utility's meter, the data is read and interpreted to obtain the current demand information. Accumulated energy is computed, and pulses are outputted according to a selected pulse value. All system settings are accomplished through a USB programming port that provides for pulse value, meter multiplier, output mode, and pulse timing. The output is selectable as either Form A (2-Wire) or Form C (3-Wire) and operates in either the momentary or toggle mode, respectively. The momentary mode has six pulse width time settings: 25mS, 50mS, 100mS, 200mS or 500mS and 1000mS. The toggle mode toggles back and forth to the opposite state upon each new pulse being generated. There are two LED's, one red and one green, which show pulse output status.

The output pulse value is selectable from 1 to 99999 watt-hours per pulse. A meter multiplier of 1 to 99999 may be programmed into the MPG-3E using the SSI Universal Programmer software.

A 30mS fixed minimum-off time delay prevents pulses from occurring too rapidly. Bright red, yellow and green LEDs monitor the system communications status and provide an easy and immediate visual system check without test equipment.

The Zigbee module must be paired or "provisioned" with the AMI meter with a HAN network radio, a process that is performed by the participating utility or on the utility's website. Once paired with the meter, the MPG-3E will begin receiving information from the meter and generating pulses.

The MPG-3E is compatible with Self-Contained or Instrument-rated electric meters. The MPG-3E's USB programming port is used to enter the specific site's meter multiplier from 1 to 99999. In addition, the MPG-3E can be configured for Normal mode (kWh delivered only) for unidirectional energy flow, or for Signed mode (kWh delivered and received) for bi-directional energy flow.



SPECIALTY DEVICES

MPG-3E WIRELESS PULSE GENERATOR

SPECIFICATIONS

ELECTRICAL

Power Input:	120, 208-277 VAC. Burden: 10 VA
Input:	Zigbee HAN Network with AMI meter
Output:	Two Form A (2-Wire) or Form C (3-wire) Solid State dry-contact outputs rated at 100mA at 120V, 800mW maximum, fused at .1A
Maximum Pulse Output Rate:	≈15 Pulses per second (Form C) ≈10 pulses per second (Form A)
Minimum Time between Output Pulses:	30ms
Form A Pulse Width:	25, 50, 100, 200, 500, 1000 mS
Output Pulse Values:	1-99999 Wh/pulse

MECHANICAL

Mounting:	Any position
Size:	8" wide, 9" high, 3" deep NEMA Standard
Weight:	4 pounds

TEMPERATURE

Temperature Range:	-38° C to +70° C, -36.4° F to +158° F
Humidity:	0 to 98% non-condensing

AVAILABLE OPTIONS

Input Voltages:	Contact factory
Enclosures:	NEMA 4X fiberglass raintight and dustproof enclosure available. 10.0" high, 8.0" wide, 4.0" deep, includes mounting plate

MPG-3E



SPECIALTY DEVICES

MPG-3ES WIRELESS PULSE GENERATOR

DESCRIPTION

The MPG-3ES Wireless Meter Pulse Generator is part of SSI's third generation Zigbee Pulse Generator family. It integrates AMI smart meters with legacy KYZ pulse metering. Using Zigbee® radio technology, the MPG-3ES receives usage data from the meter's HAN network, interprets power usage, and converts it into KY pulses. With the MPG-3ES, pulses are synthesized without having an actual KYZ output in the meter. By using the MPG-3ES, utilities and energy management contractors, value-added resellers and consultants can quickly and easily provide pulses to customer equipment.



FUNCTIONAL SUMMARY

	IN	OUT
#	1	1
TYPE	USB Zigbee® Radio Module	2 Wire
FORM	---	A

MPG-3ES

The low-cost “bare bones” MPG-3ES features integral Zigbee radio module and one KY (Form A, 2-Wire) pulse output. The MPG-3ES has a low-voltage AC or DC power supply input for use with other control products having a low voltage source already available. No line voltage source is required.

As the MPG-3ES receives periodic data from utility's meter, the data is read and interpreted to obtain the current demand information. Accumulated energy is computed, and pulses are outputted according to a selected pulse value.

All system settings are accomplished through a USB programming port using the SSI Universal Programmer software. Programmable settings are available for pulse value, meter multiplier, output mode, pulse timing and several other system settings.

An output pulse value is selectable from 1 to 99999 watt-hours per pulse, while a meter multiplier of 1 to 99999 may be programmed. The output mode is selectable as either Form A (momentary) or Form C (toggle). The momentary mode has six pulse width time settings: 25mS, 50mS, 100mS, 200mS or 500mS and 1000mS. The toggle mode toggles on and off in a 50/50 duty cycle format. A red LED indicates the pulse output status. A 30mS fixed minimum-off time delay prevents pulses from occurring too rapidly. Bright red, yellow and green LEDs monitor the system communications status and provide an easy and immediate visual system check without test equipment.

The Zigbee module must be paired or “provisioned” with the AMI meter with a HAN network radio, a process that is performed by the participating utility or on the utility's website. Once paired with the meter, the MPG-3ES will begin receiving information from the meter and generating pulses.

The MPG-3ES is compatible with both Self-contained or Instrument-rated electric meters. In addition, unidirectional and bi-directional energy flow applications can be accommodated with the MPG-3ES by selecting Normal mode (kWh delivered only) or Signed mode (kWh delivered and received) in the configuration.



SPECIALTY DEVICES

MPG-3ES WIRELESS PULSE GENERATOR

SPECIFICATIONS

ELECTRICAL

Power Input:	10-60VDC, 12-48VAC
Input:	Zigbee HAN Network with AMI meter
RF:	Zigbee Module
Output:	One Form A (2-Wire) Solid State dry-contact output rated at 100mA at 120V, 800mW maximum, fused at .1A
Maximum Pulse Output Rate:	≈15 Pulses per second (Form C) ≈8 pulses per second (Form A)
Minimum Time between Output Pulses:	30ms
Form A Pulse Width:	25, 50, 100, 200, 500, 1000 mS
Output Pulse Values:	1-99999 Wh/pulse

MECHANICAL

Mounting:	Any position; Four Mounting tabs provided
Size:	4" wide, 4" high, 2" deep
Weight:	1 pound

TEMPERATURE

Temperature Range:	-38° C to +70° C, -36.4° F to +158° F
Humidity:	0 to 98% non-condensing

MPG-3ES



SPECIALTY DEVICES

MPG-3SC WIRELESS METER PULSE GENERATOR

DESCRIPTION

The MPG-3SC Wireless Meter Pulse Generator is SSI's third generation Zigbee Pulse Generator. It integrates AMI smart meters with legacy KYZ pulse metering. Using Zigbee® radio technology, the MPG-3SC receives usage data from the meter's HAN network, interprets power usage, and converts it into KYZ pulses. With the MPG-3SC, pulses are synthesized without having an actual KYZ output in the meter. By using the MPG-3SC, utilities can implement the new advanced AMI meters and still provide pulses to customers that may need them.



The MPG-3SC features integral Zigbee radio module and two KYZ pulse outputs, in a fiberglass NEMA 4X enclosure. As the MPG-3SC receives periodic data from utility's meter, the data is read and interpreted to obtain the current demand information. Accumulated energy is computed, and pulses are outputted according to a selected pulse value.

All system settings are accomplished through a USB programming port that provides for pulse value, meter multiplier, output mode, and pulse timing. The output is selectable as either Form A (2-Wire) or Form C (3-Wire) and operates in either the momentary or toggle mode, respectively. The momentary mode has six pulse width time settings: 25mS, 50mS, 100mS, 200mS or 500mS and 1000mS. The toggle mode toggles back and forth to the opposite state upon each new pulse being generated. There are two LED's, one red and one green, which show pulse output status.

The output pulse value is selectable from 1 to 99999 watt-hours per pulse. A meter multiplier of 1 to 99999 may be programmed into the MPG-3SC using the SSI Universal Programmer software.

A 30mS fixed minimum-off time delay prevents pulses from occurring too rapidly. Bright red, yellow and green LEDs monitor the system communications status and provide an easy and immediate visual system check without test equipment.

The Zigbee module must be paired or "provisioned" with the AMI meter with a HAN network radio, a process that is performed by the participating utility or on the utility's website. Once paired with the meter, the MPG-3SC will begin receiving information from the meter and generating pulses.

The MPG-3SC is compatible with Self-Contained or Instrument-rated electric meters. The MPG-3SC's USB programming port is used to enter the specified site's meter multiplier from 1 to 99999. In addition, the MPG-3SC can be configured for Normal mode (kWh delivered only) for unidirectional energy flow, or for Signed mode (kWh delivered and received) for bi-directional energy flow. The MPG-3 also supports End-Of-Interval capability with a Form A (2-wire) output for intervals over a wide range.

FUNCTIONAL SUMMARY

	IN	OUT
#	1, 1	2+1A
TYPE	USB Zigbee® Radio Module	2 Wire or 3 Wire
FORM	---	A or C, A for EOI

MPG-3SC



SPECIALTY DEVICES

MPG-3SC WIRELESS METER PULSE GENERATOR

SPECIFICATIONS

ELECTRICAL

Power Input:	120, 208-277 VAC. Burden: 10 VA
Input:	Zigbee HAN Network with AMI meter
Output:	Two Form A (2-Wire) or Form C (3-wire) Solid State dry-contact outputs rated at 100mA at 120V, 800mW maximum, fused at .1A
Maximum Pulse Output Rate:	≈15 Pulses per second (Form C) ≈10 pulses per second (Form A)
Minimum Time between Output Pulses:	30ms
Form A Pulse Width:	25, 50, 100, 200, 500, 1000 mS
Output Pulse Values:	1-99999 Wh/pulse
End of Interval Output:	1 Form A (2-wire) output for EOI
Interval Lengths:	1, 5, 10, 15, 30, 60 minutes
Interval Pulse Widths:	50, 100, 250, 500, 1000, 2000, 5000, 10000mS

MECHANICAL

Mounting:	Any position
Size:	9.5' wide, 11.5' high, 4 3/8" deep
Weight:	7 pounds

TEMPERATURE

Temperature Range:	-38° C to +70° C, -38.4° F to +158° F
Humidity:	0 to 98% non-condensing

AVAILABLE OPTIONS

Input Voltages:	Contact factory
Enclosures:	NEMA 4X fiberglass raintight and dustproof enclosure available. 10.0" high, 8.0" wide, 4.0" deep, includes mounting plate

MPG-3SC



SPECIALTY DEVICES

MPG-3SC-R22 WIRELESS METER

DESCRIPTION

The MPG-3SC-R22 is a combination of SSI's Wireless MPG-3SC Zigbee Meter Pulse Generator and a 2 channel Isolation Relay when both are needed for unique applications. It integrates AMI smart meters with legacy KYZ pulse metering for kWh Energy pulses. Using Zigbee® radio technology, the MPG-3SC-R22 receives usage data from the meter's HAN network, interprets power usage, and converts it into KYZ pulses. With the MPG-3SC-R22, pulses are synthesized without having an actual KYZ output in the meter.

By using the MPG-3SC, utilities can implement the new advanced AMI meters and still provide pulses to customers that may need them. In addition if kVarh pulses or kVAh pulses are required, they can be isolated from the meter using the 2-channel hardwired isolation relay integrated into the MPG-3SC-R22.



The MPG-3SC-R22 features integral Zigbee radio module and two KYZ pulse outputs, in a fiberglass NEMA 4X enclosure for kWh pulses. As the MPG-3SC-R22 receives periodic data from utility's meter, the data is read and interpreted to obtain the current demand information. Accumulated energy is computed, and pulses are outputted according to a selected pulse value. For kVarh or kVAh pulses, inputs are connected to hardwired outputs of the electric meter's KYZ outputs. These isolated pulse channels are available in the customer compartment, along with the Zigbee-generated pulse outputs.

All system settings are accomplished through a USB programming port that provides access for programming the pulse value, meter multiplier, output mode, and pulse timing. The output is selectable as either Form A (2-Wire) or Form C (3-Wire) and operates in either the momentary or toggle mode, respectively. The momentary mode has six pulse width time settings: 25mS, 50mS, 100mS, 200mS or 500mS and 1000mS. The toggle mode toggles back and forth to the opposite state upon each new pulse being generated. There are two LED's, one red and one green, which show pulse output status.

The output pulse value is selectable from 1 to 99999 watt-hours per pulse. A meter multiplier of 1 to 99999 may be programmed into the MPG-3SC using the SSI Universal Programmer software.

A 30mS fixed minimum-off time delay prevents pulses from occurring too rapidly. Bright red, yellow and green LEDs monitor the system communications status and provide an easy and immediate visual system check without test equipment.

The Zigbee module must be paired or "provisioned" with the AMI meter with a HAN network radio, a process that is performed by the participating utility or on the utility's website. Once paired with the meter, the MPG-3SC-R22 will begin receiving information from the meter and generating pulses.

The MPG-3SC-R22 is compatible with Self-Contained or Instrument-rated electric meters. The MPG-3SC-R22's USB programming port is used to enter the specific site's meter multiplier from 1 to 99999. In addition, the MPG-3SC-R22 can be configured for Normal mode (kWh delivered only) for unidirectional energy flow, or for Signed mode (kWh delivered and received) for bi-directional energy flow. The MPG-3SC-R22 also supports End-Of-Interval capability with a Form A (2-wire) output for intervals over a wide range.

FUNCTIONAL SUMMARY

	IN	OUT
#	1, 1 2C	2+1A 2C
TYPE	USB Zigbee® Radio Module; 2 3-wire	2 Wire or 3 Wire; 3-Wire
FORM	--	A or C, A for EOI; C

MPG-3SC-R22

SOLID STATE INSTRUMENTS A Product Family Owned by RADIAN RESEARCH

3852 Fortune Dr. • Lafayette, IN • Ph: 765-449-5500 • Fax: 765-448-4614

www.radianresearch.com



MPG-3SC-R22

SPECIALTY DEVICES

MPG-3SC-R22 WIRELESS METER

SPECIFICATIONS

ELECTRICAL

Power Input:	Autoranging 120-277 VAC. Burden: 10 VA
Input:	Zigbee HAN Network with AMI meter Two Form A or C dry-contact compatible pulse inputs
Output:	Two Form A (2-Wire) or Form C (3-wire) Solid State dry-contact outputs rated at 100mA at 120V, 800mW maximum, fused at .1A Two Form C (3-Wire Solid State dry-contact outputs rated at 500mA at 120V, 800mW maximum, fused at .5A
Maximum Pulse Output Rate:	≈15 Pulses per second (Form C) ≈10 pulses per second (Form A)
Minimum Time between Output Pulses:	30ms
Form A Pulse Width:	25, 50, 100, 200, 500, 1000 mS
Output Pulse Values:	1-99999 Wh/pulse
End of Interval Output:	1 Form A (2-wire) output for EOI
Interval Lengths:	1, 5, 10, 15, 30, 60 minutes
Interval Pulse Widths:	50, 100, 250, 500, 1000, 2000, 5000, 10000mS

MECHANICAL

Mounting:	Any position
Size:	9.5' wide, 11.5' high, 4 3/8" deep
Weight:	7 pounds

TEMPERATURE

Temperature Range:	-38° C to +70° C, -38.4° F to +158° F
Humidity:	0 to 98% non-condensing

AVAILABLE OPTIONS

Input Voltages:	Contact factory
Enclosures:	NEMA 4X fiberglass raintight and dustproof enclosure available. 10.0" high, 8.0" wide, 4.0" deep, includes mounting plate



PULSE LINKS

CLS-1 CURRENT LOOP RELAY

DESCRIPTION

The CLS-1 is a current loop switch relay designed to sense the current in a 4-20mA current loop and switch a normally-open relay when the loop current exceeds the setpoint. The CLS-1 is self-powered from the current loop and requires no external power supply to operate. One Normally-Open Solid State Dry Contact output is provided to switch a small load or control circuit up to 300mA at a voltage up to 120VAC/VDC.



Applications include controlling loads or signaling the status of the current loop.

The CLS-1 contain two high light output red and green LED's. The Green LED indicates that the CLS-1 has power applied from the loop power supply, while the Red LED indicates when the relay is energized. This allows a continuous display the system's status at all times without requiring any additional test equipment. Provision is made to read the loop current with a DVM meter is desired.

The CLS-1's input and output circuit's terminal strip is a "Euro" type connector. When the stripped wire has been correctly installed in the terminal's slot, no conductive parts are exposed on the surface of the terminal strip. Due to the inherent current-limited nature of the design, no fusing is necessary on the input.

The "CLS-1's relay output is rated at 500mA (.5A) and is fused to prevent damage to the relay under almost any conditions a user might encounter such as excessive current, incorrect wiring, etc. The CLS-1's output relay also has a built-in MOV transient protection for the solid-state relay contact. All component parts which have voltage applied to them, with the exception of the input-output terminal strip, are enclosed in a polycarbonate cover for maximum user protection. The mounting base plate is also made of polycarbonate and offers excellent electrical insulation between the circuit and the mounting surface. The CLS-1 is designed to mount inside another enclosure, suitable for the user's intended application.

FUNCTIONAL SUMMARY

	IN	OUT
#	1	1
TYPE	CL	2 Wire
FORM	CL	A

CLS-1



PULSE LINKS

CLS-1 CURRENT LOOP RELAY

SPECIFICATIONS

ELECTRICAL

Power Input:	No power supply required; powered by current loop.
Relay Contact On-State Resistance:	5 ohms maximum, 3.4 Ohms typical
Insulation Resistance:	50 megohms typical
Operate and Release Time:	Turn On Time - 5 mS typical; 20 mS MAX Turn Off Time - 1 mS typical; 5 mS MAX
Input/Output Isolation Voltage:	2500Vrms

MECHANICAL

Mounting:	Any position
Size:	3.27" wide, 5.7" high, 1.5" deep
Weight:	10 - 12 ounces

TEMPERATURE

Temperature Range:	-38° C to +70° C, -38.4° F to +158° F
Humidity:	0 to 98% non-condensing

CLS-1



SPECIALTY DEVICES

PMC-1 PULSE-TO-MODBUS CONVERTER

DESCRIPTION

The PMC-1 Pulse-to-Modbus Converter is a device designed to read, record and store pulses from two 2-Wire KY pulse inputs and provide access to the energy use and demand information using the Modbus TCP protocol. Pulse inputs are recorded in the count register and the equivalent energy value is calculated and recorded in the energy use register. The PMC-1's inputs provide a +13VDC wetting voltage for the meters' dry-contact outputs. Upon receiving each pulse from the meter, the PMC-1's microcontroller converts the pulse to the kWh value and adds it to the energy use register. The instantaneous, average and peak demand (kW) are also captured and available in three separate registers for each channel. Average and Peak Demands are based on a 15 minute demand interval.



Energy use information collected and stored in non-volatile memory and accessible by using the RJ-45 Ethernet connection of the PMC-1. The Modbus protocol allows accessing the specific PMC-1 device using a unique IP address, and the register for the information of the pulse channel desired. A RS-232C DB9 serial port allows quick programming of the IP address and pulse value. A master reset capability allows all registers to be cleared.

The PMC-1's bright red LED lamps indicate the Pulse input's status at all times. Eight additional green LED's indicate device and network status.

Read-only Registers accessible for each channel are:

- Cumulative energy since last reset or rollover (kWh)
- Instantaneous Demand (kW)
- Average Demand (kW)
- Peak Demand since last reset (kW)
- Time since last power up (seconds)
- Pulse Count since last reset (number)

Programmable values are:

- Pulse Constant (kWh/pulse) for each channel
- Pulse Value Type (2-wire or 3-wire)
- Reset all registers

Typical applications include:

- Provide real-time energy and power measurements for Energy Management Systems, Dashboards, software applications or web clients
- Access, View and Track Energy Use and Demand information
- Generate interval data and load profiles
- Demand Response program monitoring
- Utility submetering (electricity, gas, water, etc.)
- M&V Measurement and Verification of Energy Efficiency Measures
- Utility meter Verification

FUNCTIONAL SUMMARY

	IN	OUT
#	2	-
TYPE	2 Wire	-
FORM	A	-

PMC-1

SOLID STATE INSTRUMENTS A Product Family Owned by RADIAN RESEARCH

3852 Fortune Dr. • Lafayette, IN • Ph: 765-449-5500 • Fax: 765-448-4614

www.radianresearch.com



SPECIALTY DEVICES

PMC-1 PULSE-TO-MODBUS CONVERTER

SPECIFICATIONS

ELECTRICAL

Power Input:	120VAC by 12VAC wall transformer (included); Burden: 10 MA. at 120 VAC
Pulse Input:	Two KY Form A (2-wire) inputs with +13VDC wetting voltage compatible with dry contact or open-collector transistor output. Detachable terminal block.
Maximum Input Pulse Rate:	10 pulses per second
Pulse value:	.001kWh/p to 655.35 kwh/p, in .0001 kWh increments.
Output:	No Hardware outputs; Register reads only
Network Interface:	RJ-45 Ethernet
Protocol:	Modbus TCP
Demand Averaging Interval Selection:	15 minutes
Peak Demand Reset, by channel:	Yes
Reset Cumulative Energy, by channel:	Yes
Reset Cumulative Raw Pulse Count, by channel:	Yes

MECHANICAL

Mounting:	Any position.
Size:	2.30" wide, 4.8" long, 1.50" deep
Weight:	17 ounces

TEMPERATURE

Temperature Range:	-38° C to +70° C, -36.4° F to +158° F
Humidity:	0 to 98% non-condensing

AVAILABLE OPTIONS

Input Voltages:	12VAC. Contact Factory.
-----------------	-------------------------

PMC-1



SPECIALTY DEVICES

EXP EXPANSION BOARDS

DESCRIPTION

The EXP Expansion boards are designed for use with SSI's PMC-1 V5 Pulse-to-Modbus Converter. They are available in 2-input, 4-input or 6-input models, allowing the PMC-1 to be expanded to a total of 4, 6 or 8 input channels respectively. No additional power supply is required to power the EXP boards since they are powered off the PMC-1. The EXP boards connect to the PMC-1's main board by means of a ribbon cable. No configuration is necessary since the PMC-1 can identify which if any of the EXP expansion boards are installed.



Each pulse input provides a nominal +12VDC wetting voltage for the meters' dry-contact output. Upon receiving each pulse from the meter, the PMC-1's microcontroller converts the pulse to the kWh value and adds it to each channel's energy use register. In addition, the accumulated raw pulse count is available for each channel.

Energy use information collected and stored in non-volatile memory and accessible by using the RJ-45 Ethernet connection of the PMC-1.

The EXP boards contain bright red LED lamps which indicate the Pulse input's status at all times.

Typical applications include:

- Provide real-time energy and power measurements for Energy Management Systems, Dashboards, software applications or web clients
- Access, View and Track Energy Use and Demand information
- Generate interval data and load profiles
- Demand Response program monitoring
- Utility submetering (electricity, gas, water, etc.)
- M&V Measurement and Verification of Energy Efficiency Measures
- Utility meter Verification



EXP EXPANSION BOARDS

SPECIALTY DEVICES

EXP EXPANSION BOARDS

SPECIFICATIONS

ELECTRICAL

Power Input:	No power required. EXP boards are powered from the PMC-1 V5
Pulse Input:	Two to Six KY Form A (2-wire) inputs with +12VDC wetting voltage compatible with dry contact or open-collector transistor output. Detachable terminal block.
Maximum Input Pulse Rate:	10 pulses per second
Pulse value:	.001kWh/p to 655.35 kwh/p, in .0001 kWh increments.
Output:	No Hardware outputs; Register reads only
Protocol:	Modbus TCP

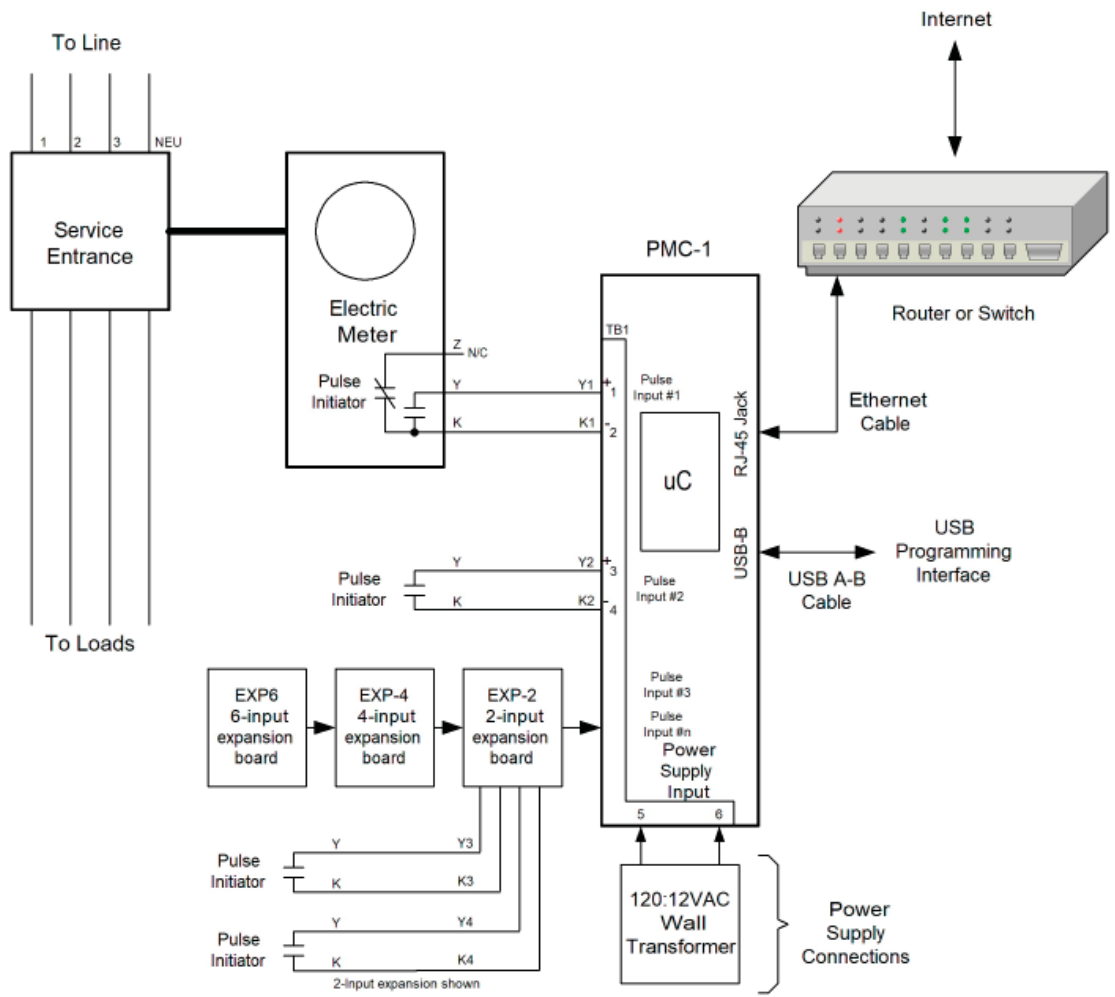

TERMINATION DEVICES

CID-1 CUSTOMER INTERFACE DEVICE

DESCRIPTION

The CID-1 Customer Interface Device is a low-cost, fused KYZ termination device which supplements the electric meter's KYZ pulse initiator. It provides two sets of K, Y, & Z connector terminals, one for connection to the meter's K, Y, and Z output terminals and the other for the utility customer's energy control system input terminals.

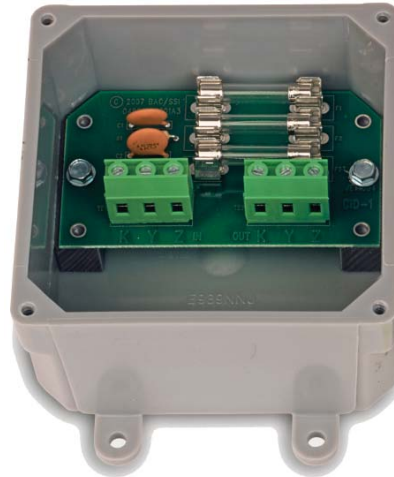

The CID-1's mounting configurations incorporates four knockouts for 1/2" electrical conduit which can be used in a wide range of connection schemes to the electric meter's enclosure.

The CID-1's input and output circuit's terminal strips are "EURO" type. When the stripped wire has been correctly installed in the terminals "slot", no conductive parts are exposed on the surface of the terminal strip, thus allowing the user maximum protection from accidental electrical shock. Each lead of the CID-1 is individually fused. The K fuse and either the Y or the Z fuse are in series at all times providing a coordinated fusing scheme designed to prevent damage to the meter or the customer's energy control system. In addition, this fuse configuration provides the provision for master/slave fusing. A built-in "snubber" network is installed to suppress excessive transient voltages.

The CID-1 features a watertight Noryl enclosure and offers excellent electrical insulation. A beaded-gasket lid ensures that the circuit inside remains dry and clean.

FUNCTIONAL SUMMARY

	IN	OUT
#	1	1
TYPE	2 or 3 Wire	2 or 3 Wire
FORM	A or C	A or C

CID-1



TERMINATION DEVICES

CID-1 CUSTOMER INTERFACE DEVICE

SPECIFICATIONS

ELECTRICAL

Maximum Voltage:	250VAC/VDC
Input/Output Resistance:	50 milliohms maximum
Insulation Resistance:	50 megohms typical

MECHANICAL

Mounting:	Any position
Size:	4.5" wide, 4.5" high, 2.25" deep
Weight:	~1 pound, depending on mounting configuration

TEMPERATURE

Temperature Range:	-38° C to +70° C, -36.4° F to +158° F
Humidity:	0 to 98% non-condensing

CID-1



TERMINATION DEVICES

CID-2 CUSTOMER INTERFACE DEVICE

DESCRIPTION

The CID-2 Customer Interface Device is a 2-channel low-cost, fused KYZ termination device which supplements the electric meters' KYZ pulse initiators. It provides two sets of K, Y, & Z connector terminals, one for connection to the two meters' K, Y, and Z output terminals and the other for the utility customer's energy control system input terminals.



FUNCTIONAL SUMMARY

	IN	OUT
#	2	2
TYPE	2 or 3 Wire	2 or 3 Wire
FORM	A or C	A or C

The CID-2's mounting configurations incorporates four knockouts for 1/2" electrical conduit which can be used in a wide range of connection schemes to the electric meter's enclosure.

The CID-2's input and output circuit's terminal strips are "EURO" type. When the stripped wire has been correctly installed in the terminals "slot", no conductive parts are exposed on the surface of the terminal strip, thus allowing the user maximum protection from accidental electrical shock. The K lead of each channel is individually fused designed to prevent damage to the meter or the customer's energy control system. A built-in "snubber" network is installed to suppress excessive transient voltages.

The CID-2 features a watertight Noryl enclosure and offers excellent electrical insulation. A beaded-gasket lid ensures that the circuit inside remains dry and clean.

CID-2



TERMINATION DEVICES

CID-2 CUSTOMER INTERFACE DEVICE

SPECIFICATIONS

ELECTRICAL

Maximum Voltage:	250VAC/VDC
Input/Output Resistance:	50 milliohms maximum
Insulation Resistance:	50 megohms typical

MECHANICAL

Mounting:	Any position
Size:	4.5" wide, 4.5" high, 2.25" deep
Weight:	~1 pound, depending on mounting configuration

TEMPERATURE

Temperature Range:	-38° C to +70° C, -36.4° F to +158° F
Humidity:	0 to 98% non-condensing

CID-2



TERMINATION DEVICES

CID-3 CUSTOMER INTERFACE DEVICE

DESCRIPTION

The CID-3 Customer Interface Device is a low-cost 3-channel, fused KYZ termination device which supplements the electric meters' KYZ pulse initiators. It provides three sets of K & Y connector terminals, one for connection to the three meters' K and Y output terminals and the other for the utility customer's energy control system input terminals.



The CID-3's mounting configurations incorporates four knockouts for 1/2" electrical conduit which can be used in a wide range of connection schemes to the electric meter's enclosure.

The CID-3's input and output circuit's terminal strips are "EURO" type. When the stripped wire has been correctly installed in the terminals "slot", no conductive parts are exposed on the surface of the terminal strip, thus allowing the user maximum protection from accidental electrical shock. Each K lead of the CID-3 is individually fused. A built-in "snubber" network is installed for transient suppression.

The CID-3 features a watertight Noryl enclosure and offers excellent electrical insulation. A beaded-gasket lid ensures that the circuit inside remains dry and clean.

CID-3

FUNCTIONAL SUMMARY

	IN	OUT
#	3	3
TYPE	2 Wire	2 Wire
FORM	A	A

#

TYPE

FORM

SOLID STATE INSTRUMENTS A Product Family Owned by RADIAN RESEARCH

3852 Fortune Dr. • Lafayette, IN • Ph: 765-449-5500 • Fax: 765-448-4614

www.radianresearch.com



TERMINATION DEVICES

CID-3 CUSTOMER INTERFACE DEVICE

SPECIFICATIONS

ELECTRICAL

Maximum Voltage:	250VAC/VDC
Input/Output Resistance:	50 milliohms maximum
Insulation Resistance:	50 megohms typical

MECHANICAL

Mounting:	Any position
Size:	4.5" wide, 4.5" high, 2.25" deep
Weight:	~1 pound, depending on mounting configuration

TEMPERATURE

Temperature Range:	-38° C to +70° C, -38.4° F to +158° F
Humidity:	0 to 98% non-condensing

CID-3



TERMINATION DEVICES

CID-4 CUSTOMER INTERFACE DEVICE

DESCRIPTION

The CID-4 customer interface device is a low-cost, fused KYZ pulse termination and telecom device which supplements the electric meter's KYZ pulse initiator and modem. It provides two sets of K, Y, & Z connector terminals, one for connection to the meter's K, Y, and Z output terminals and the other for the utility customer's energy control system input terminals. In addition, the CID-4 provides two RJ-11 or RJ12 phone jacks as a termination point for the meter's modem and the incoming phone line, while supplying additional surge protection against transient voltage that may affect the inner wirings of the site. Connections to an electric meter's modem to the telephone line are compact, simple and easy.



The CID-4's mounting configurations incorporates four knockouts for 1/2" electrical conduit which can be used in a wide range of connection schemes to the electric meter's enclosure.

The CID-4's pulse input and output circuit's terminal strips are "EURO" type. When the stripped wire has been correctly installed in the terminals "slot", no conductive parts are exposed on the surface of the terminal strip, thus allowing the user maximum protection from accidental electrical shock. The K output of the CID-4 is fused providing current limiting designed to prevent damage to the meter or the customer's energy control system. In addition, a built-in MOV transient voltage network is installed to suppress excessive transient voltages. Specialized Telecom surge suppression and fusing is included.

The CID-4 features a watertight Noryl enclosure and offers excellent electrical insulation. A beaded-gasket lid ensures that the circuit inside remains dry and clean.

FUNCTIONAL SUMMARY

	IN	OUT
#	1	1
TYPE	2 or 3 Wire	2 or 3 Wire
FORM	A or C	A or C
TELCO	RJ-11 (std)	RJ-11 (std)

CID-4



TERMINATION DEVICES

CID-4 CUSTOMER INTERFACE DEVICE

SPECIFICATIONS

ELECTRICAL

Input/Output Voltage:	120 VAC
Input/Output Resistance:	50 milliohms maximum
Insulation Resistance:	50 megohms typical

MECHANICAL

Mounting:	Any position
Size:	4.5" wide, 4.5" high, 2.25" deep
Weight:	~1 pound, depending on mounting configuration

TEMPERATURE

Temperature Range:	-38° C to +70° C, -36.4° F to +158° F
Humidity:	0 to 98% non-condensing

All specifications are subject to change without notice.

CID-4



MPS-2 METERING POWER SUPPLY

DESCRIPTION

The MPS-2 metering power supply, a low-cost DC power supply option, provides an isolated low-voltage DC wetting voltage designed specifically for KYZ pulse metering applications.

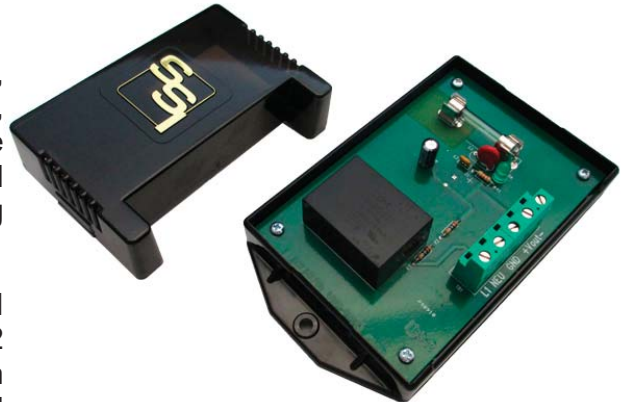

Packaged in the convenient SSI "small footprint" case, the MPS-2 can be used in any application where a wetting voltage is needed to go through a KYZ pulse initiator and into another pulse input device such as a SCADA system, RTU, energy management system, KYZ pulse totalizer, electric meter pulse input or other telemetry or control systems which accept pulses.

The MPS-2 is available in standard outputs of:

- MPS-2-12 (12VDC)
- MPS-2-15 (15VDC)
- MPS-2-24 (24VDC)

The power supply's low-current design provides up to 300mA for the pulse metering circuit. The output is internally current-limited and provides a fuse to prevent damage in the event of a short circuit condition. In addition, the MPS-2 power supply includes MOV transient suppression devices on both the AC power supply input and the DC output.

MPS-2

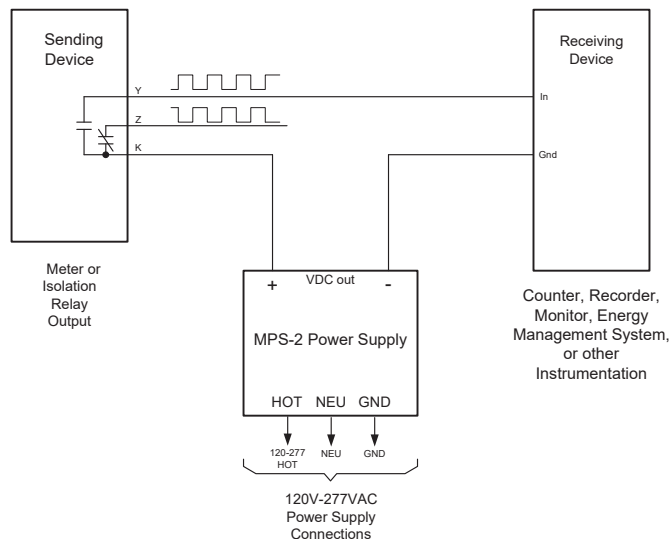



SPECIALTY DEVICES

MPS-2 METERING POWER SUPPLY

SPECIFICATIONS

ELECTRICAL

Power Input:	120-277 VAC
Output Voltage:	+12VDC, +18VDC, +24VDC specified at the time of order
Output Current:	300mA @ 12VDC, 250mA @ 15VDC, Nominal 150mA @ 24VDC
Output Fuse:	0.1A (100mA)
Voltage Regulation:	0.5%

MECHANICAL

Mounting:	Any position
Size:	3.27" wide, 5.7" high, 1.50" deep
Weight:	6 ounces

TEMPERATURE

Temperature Range:	-38° C to +70° C, -36.4° F to +158° F
Humidity:	0 to 98% non-condensing

AVAILABLE OPTIONS

Input Voltages:	Contact Factory
-----------------	-----------------

MPS-2



SPECIALTY DEVICES

P-1 PULSER PULSE GENERATOR

DESCRIPTION

The P-1 Pulser is a handy pulse generator designed to provide a Form C (KYZ) output to telemetry, recorders, energy management systems or similar devices to simulate the electric meter's KYZ pulse output. In this way, the user or technician can determine that the pulse receiving device or system is detecting the pulses correctly. Either a Form A (KY) output using 2 wires or a Form C (KYZ) using all three wires can be simulated from the P-1. The P-1 Pulser has three sources of pulses selectable: 1Hz precision pulse, a variable 1Hz to 10Hz pulse or an external pulse input for use with a function or signal generator.



The P-1 operates on 12VDC. The unit includes a 12VDC plug-in “Wall Wart” power supply for easy connection to a 120VAC source.

The P-1's output is configured as an optically--isolated, dry-contact, solid state output with a 100mA maximum current rating similar to the contact rating of all electric meters. Further, it contains built-in MOV transient protection for the solid-state relay contacts which eliminates the need for external or off-the-board transient suppressors. The output terminals are Red, Yellow and Black banana jacks, the standard code for KYZ outputs.

The P-1's external pulse input is dry-contact compatible making it current limited and easy to use with a variety of function generators or signal generators. The P-1 Pulser's external input is designed for high-speed pulses and can switch up to 72,000 pulses/hour.

Bright RED and GREEN LED indicators, display the K-Y or K-Z continuity status at all times thus allowing a rapid check of the pulser's performance without requiring any additional test equipment.

The P-1's enclosure is made of NORYL plastic and offers superior wear and electrical insulation between the circuits and the mounting surface.

P-1



SPECIALTY DEVICES

P-1 PULSER PULSE GENERATOR

SPECIFICATIONS

ELECTRICAL

Power Input:	12 VDC. Burden: 20 mA 120 VAC input with 12VDC Wall Wart Power Supply included with P-1
Pulse Input Modes:	1 Hz Continuous precision reference 1Hz to 10 Hz Variable External Input from Pulse Generator - One Form A input dry-contact compatible input. "Kin" is (-) common return. "Yin" is + positive input pulse signal.
Outputs:	One set of dry Form C contacts (K, Y & Z) for energy pulses. The contacts are rated at 125VAC/VDC at 100milliamps. The maximum rating of the contacts is 800mW. The output is factory fused at 1/10 amp. (3AG)
Contact On-State Resistance:	25 ohms maximum, 18 typical
Operate and Release Time:	Turn On Time - .5 mS typical; 3 mS MAX Turn Off Time - .1 mS typical; 1 mS MAX
Input/Output Isolation Voltage:	3750Vrms

MECHANICAL

Mounting:	Any position
Size:	4.0" wide, 4.0" high, 2.25" deep
Weight:	< 1 lb

TEMPERATURE

Temperature Range:	-38° C to +70° C, -38.4° F to +158° F
Humidity:	0 to 98% non-condensing

AVAILABLE OPTIONS

Input Voltages:	Contact factory for other input voltages and special orders.
-----------------	--

P-1



SPECIALTY DEVICES

PPC-1B PORTABLE PULSE COUNTER

DESCRIPTION

The PPC-1B Portable Pulse Counter is a low-cost test device for counting a meter's KYZ pulse outputs, for either field test, lab or permanent applications.

The PPC-1B supplies its own wetting (sense) voltage to one side of the new photo relay's outputs and the other lead counts the closures or "pulses" of that output. It is configured as a Form A (2-Wire) device to test one side of the Form C output at a time. The PPC-1B can be used with either mercury-wetted, electromechanical or solid-state relay outputs. It is powered with a 12VDC Wall Power Supply or another 12VDC Power Supply.



Designed for the rigors of the field, the PPC-1B is packaged in a nearly indestructible NORYL enclosure. Provided are two banana jack input leads with probes for connecting to wires or terminals of the meter's KYZ output. Upon each transition of the KYZ output, the counter will register a count and update the display. The 8-digit display allows a maximum count of 99,999,999 and features non-volatile memory of the pulse count. It can be manually reset by the field technician at any time. Thus, the PPC-1B can be used to ensure that the pulse output is operating satisfactorily. The PPC-1B's cover can be rotated by 90, 180 or 270 degrees to put the input jacks in the preferred side for your application.

PPC-1B Portable Pulse Counter

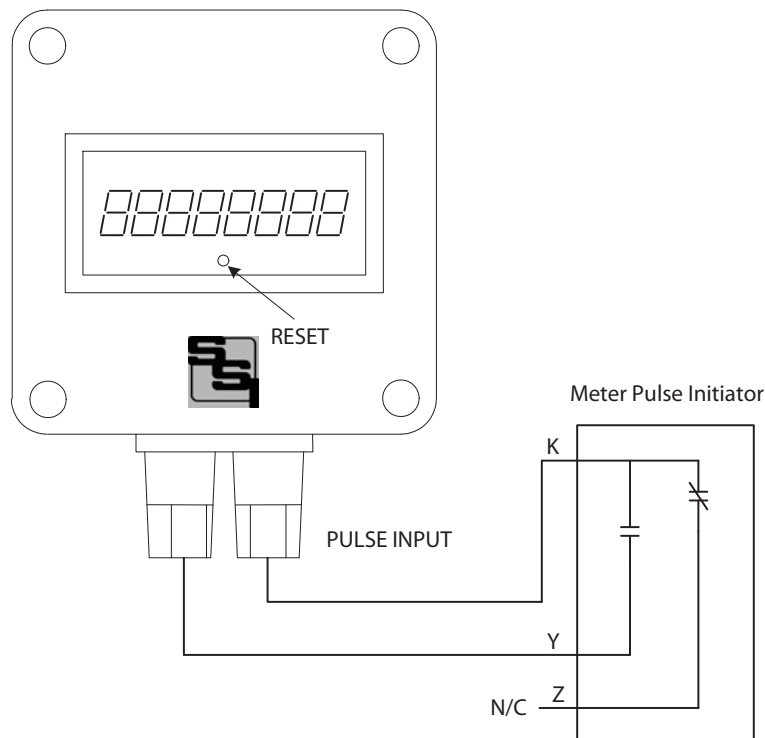

PPC-1B



SPECIALTY DEVICES

PPC-1B PORTABLE PULSE COUNTER

SPECIFICATIONS

ELECTRICAL

Power Input:	12VDC Wall Wart Plug-in Power Supply
Sense Voltage:	12 VDC
Sense Current:	<10 mA

MECHANICAL

Mounting:	Any position
Size:	4.00" wide x 4.00" high x 2.25" deep, not including mounting tabs
Weight:	2 lb.

TEMPERATURE

Temperature Range:	0° C to +50° C
Humidity:	0 to 85% non-condensing
Storage Temperature Range:	-30° C to 80° C

PPC-1B



SPECIALTY DEVICES

PPC-2 PORTABLE PULSE COUNTER

DESCRIPTION

The PPC-2 Portable Pulse Counter is a low-cost field tool for testing a meter's KYZ pulse outputs. The PPC-2 supplies its own wetting (sense) voltage to both Y and Z sides of the meter's KYZ output. The remaining lead (K) is the common return. The PPC-2 counts the closures or "pulses" of the output. It can be configured as either a Form A (2-Wire) or a Form C (3-Wire) device to test one or both sides of the Form C output. The PPC-2 can be used with either electromechanical or solid-state meter outputs, or isolation relay outputs. It is powered by a rechargeable Lithium Ion battery with a working life of 40 hours. Full recharge time is approximately 5 hours.

Designed for the rigors of the field, the PPC-2 is packaged in a nearly indestructible polycarbonate enclosure. Provided are three banana jacks (K, Y, and Z) with standard Red, Yellow and Black input leads with probes for connecting to wires or terminals of the meter's KYZ output.

Upon each transition of the KYZ switch, the counter will register a count and update the display. The 8-digit display allows a maximum count of 99,999,999 and can be manually reset by the field technician at any time. Thus, the PPC-2 can be used to ensure that the pulse output is operating correctly.



PPC-2

PPC-2 Portable Pulse Counter

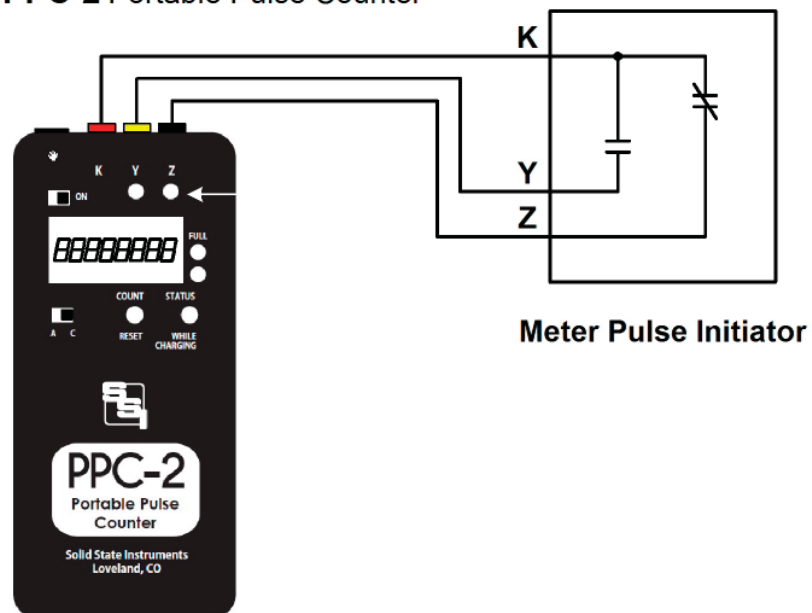



SPECIALTY DEVICES

PPC-2 PORTABLE PULSE COUNTER

SPECIFICATIONS

ELECTRICAL

Power Input:	12VDC Auto Cigarette Lighter cord ore stationary wall transformer; Normal 5-hour fullrecharge time.
Sense Voltage:	6 VDC
Sense Current:	<10 mA

MECHANICAL

Mounting:	Any position
Size:	6.80" high x 3.40" wide x 1.25" deep
Weight:	Approx. 1lb

TEMPERATURE

Temperature Range:	-10° C to +50° C, 14° F to +122° F
Storage Temperature Range:	-20° C to 70° C, -4° F to 158° F

PPC-2



SPECIALTY DEVICES

PPT-1 PORTABLE PULSE TESTER

DESCRIPTION

The PPT-1 Portable Pulse Tester is a low-cost field tester for testing a meter's KYZ pulse outputs. The PPT-1 supplies its own wetting (sense) voltage to the relay's output terminals and visually displays the closures or "pulses" of that output. It is configured in Form C (3-Wire) format, but can be used in either Form C or Form A (2-Wire) mode. The PPT-1 can be used with either mercury-wetted or solid-state relay outputs. It is battery-powered with two AA replaceable batteries.



PPT-1



SPECIALTY DEVICES

PPT-1 PORTABLE PULSE TESTER

SPECIFICATIONS

ELECTRICAL

Power Input:	None – Battery Powered; 2 replaceable AA Batteries
Sense Voltage:	3 VDC
Sense Current:	<10 mA

MECHANICAL

Mounting:	Any position
Size:	6.00" high x 1.85" wide x 1.35" deep
Weight:	1lb

TEMPERATURE

Temperature Range:	0° C to +50° C
Humidity:	0 to 85% non-condensing
Storage Temperature Range:	-30° C to 80° C

PPT-1



SPECIALTY DEVICES

OPP-1 OPTICAL PULSE PICK-UP

DESCRIPTION

The OPP-1 from Solid State Instruments is a convenient and low-cost way to monitor energy consumption information from compatible electric meters with no physical electrical connection. Using the meter's infrared calibration pulse on the Optocom port, the OPP-1 picks up the infrared light flash (pulse) each time a pre-determined number of watt-hours (usually 1 Kwh) is consumed by the customer's premises. In this way, the utility, their customer or their energy management contractor can read power from their meter temporarily for doing load survey, demand response or energy management activities quicker and at much lower cost.



Solid State Instruments' unique pulse isolation and conditioning technology allows the calibration pulse to be picked up and converted into standard Form C metering KYZ pulses to interface with power monitoring equipment that uses a pulse input. The electric meter must have the calibration pulse as the default mode on the Optocom port when the port is not being used for data uploading, downloading or other programming activities. The OPP-1 is a one directional device with read-only capability. It provides a truly secure method of acquiring power monitoring information with no hassle.

Known meters which are compatible with the OPP-1 are:

Landis + Gyr Model MAXsys Elite

GE Model KV2e

Elster Alpha 3

OPP-1



SPECIALTY DEVICES

OPP-1 OPTICAL PULSE PICK-UP

SPECIFICATIONS

ELECTRICAL

Power Input:	+13VDC provided by PCR-3 Relay (no additional power required)
Input Signal:	Input signal provided by detection of the infrared light flash from the meter's Optocom port.
Output:	Form A transistor output compatible with input of PCR-3. Output has 3-conductor 25 foot control cable for connection to PCR-3.

MECHANICAL

Mounting:	Magnetically mounts on meter's Optocom port with recessed "D" shape key.
Size:	1.20" diameter, 1.00" high.
Weight:	4 oz

TEMPERATURE

Temperature Range:	-38° C to +70° C, -36.4° F to +158° F
Humidity:	0 to 98% non-condensing

OPP-1



SPECIALTY DEVICES

OPP-1i OPTICAL PULSE PICK-UP

DESCRIPTION

The OPP-1i from Solid State Instruments is a convenient and low-cost way to monitor energy consumption information from ITRON Sentinel and Centron electric meters with no physical electrical connection. Using the meter's infrared calibration pulse front face of the Sentinel or the light pipe on the top of the Centron, the OPP-1i picks up the infrared light flash (pulse) each time a pre-determined number of watt-hours (usually 1 Kwh) is consumed by the customer's premises. In this way, the utility, their customer or their energy management contractor can quickly read power from their meter for doing load survey work, demand response or energy management activities at much lower cost than other means. Solid State Instruments' unique optical pulse isolation and conditioning technology allows the calibration pulse to be picked up and converted into standard Form C metering KYZ pulses to interface with power monitoring equipment that uses a pulse input.



The OPP-1i is a one-directional device with read-only capability. It provides a truly secure method of acquiring instantaneous power monitoring information with no hassle.

Known meters which are compatible with the OPP-1i are:

ITRON Sentinel

ITRON Centron

GE I-210

GE I-210+

OPP-1i



SPECIALTY DEVICES

OPP-1i OPTICAL PULSE PICK-UP

SPECIFICATIONS

ELECTRICAL

Power Input:	+13VDC provided by PCR-3 Relay (no additional power required)
Input Signal:	Input signal provided by detection of the infrared light flash from the meter's Calibration LED.
Output:	Form A transistor output compatible with input of PCR-3. Output has 3-conductor 25 foot control cable for connection to PCR-3.

MECHANICAL

Mounting:	Mounts to Sentinel Meter face or Centron top with suction cup.
Size:	1.20" diameter, 1.00" high.
Weight:	4 oz

TEMPERATURE

Temperature Range:	-38° C to +70° C, -36.4° F to +158° F
Humidity:	0 to 98% non-condensing

OPP-1i



SPECIALTY DEVICES

CLC-1 CURRENT LOOP CONVERTER

DESCRIPTION

The CLC-1 Current Loop Converter is a device which allows standard KYZ pulses to be converted to a format compatible for use with a 4-20mA current loop. The KYZ output from a meter or isolation relay is fed directly into the CLC-1's KYZ input. The CLC-1's input provides the +13VDC wetting voltage for the meter's dry contact pulse output. The CLC-1's output will toggle between 4mA and 20mA upon each transition of the meter's pulse initiator. There is no



scaling of interpretation of a value of a pulse. The output can be configured so that a K-Y closure will result in either 4mA or 20mA. Once set, the K-Z closure becomes the opposite milliamp output. In this way, a KYZ pulse output can be configured to interface directly to a process control system or other instrumentation with a 4-20mA input.

The 4-20mA output is current limited to insure that short circuits or excessive loading will not damage the unit. Bright red and green LED lamps indicate the input's status at all times, thus allowing a rapid check of the input's performance without requiring any special test equipment. Provisions are made to easily read the output's current level with a digital multi-meter (DMM).

Typical applications include interfaces between utility metering devices and customer-owned energy information or control systems. The CLC-1's input and output circuit's terminal strip is a "EURO" type connector strip. When the stripped wire has been correctly installed in the terminals "slot" no conductive parts are exposed on the surface of the terminal strip, thus allowing the user maximum protection from accidental electrical shock.

The CLC-1 has built-in transient protection on the 4-20mA current loop output that eliminates the need for external protection. All component parts that have power applied to them, with the exception of the input/output terminal strip are enclosed in a polycarbonate cover for maximum protection. The mounting base plate is also made of polycarbonate and offers excellent electrical insulation between the circuit and the mounting surface.

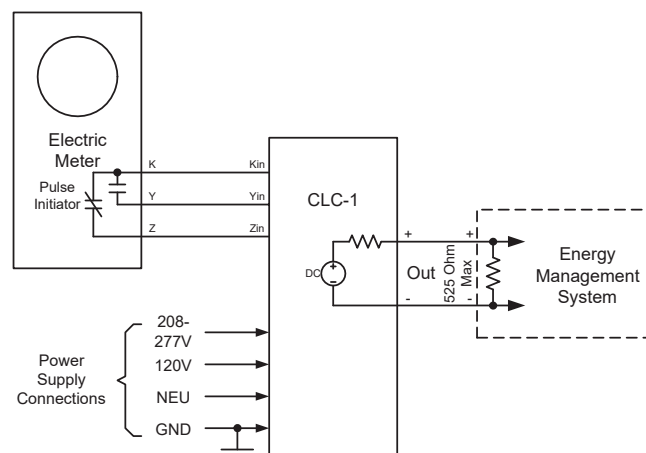



SPECIALTY DEVICES

CLC-1 CURRENT LOOP CONVERTER

SPECIFICATIONS

ELECTRICAL

Power Input:	90 to 300 VAC. Burden: 10 mA at 120 VAC
Input:	Standard KYZ pulse input, field configurable as either Form A (2-wire) or Form C (3-wire) +13VDC supplied by the CLC-1's power supply to wet meter contacts.
Output:	One active 4-20mA current loop output. No additional loop power supply is necessary since the CLC-1 provides the DC Voltage for the output.
Output Impedance:	Will drive into 525 ohms maximum, 500 ohms typical
Insulation Resistance:	10 megohms typical
Operate Time:	20 milliseconds typical

MECHANICAL

Mounting:	Any position
Size:	3.50 inches wide, 7.20 inches high, 1.50 inches deep
Weight:	17 Ounces

TEMPERATURE

Temperature Range:	-38° C to +70° C, -36.4° F to +158° F
Humidity:	0 to 98% non-condensing

AVAILABLE OPTIONS

Input Voltages:	Contact Factory
-----------------	-----------------

CLC-1



PCL-2 PULSE-TO-CURRENT LOOP CONVERTER

DESCRIPTION

The PCL-2 Pulse-to-Current Loop Converter is a device designed to convert a 2-Wire KY pulse to an analog 4-20mA signal, readable by another device with a 4-20mA input. The 4-20mA current output of the PCL-2 can be configured to represent the current Instantaneous or Average rate of usage in electric, water or gas metering applications. The KY pulse output from a meter or isolation relay is fed directly into the PCL-2's KY input. The PCL-2's input provides a +13VDC wetting voltage for the meter's dry contacts. Upon receiving each pulse from the meter, the PCL-2's microcontroller calculates the instantaneous rate of usage based on the pulse rate and value, and updates the output to a current level between 4mA and 20mA. For example, suppose you have the full-scale output of the PCL-2 configured for 500kW. If a current demand of 250kW is calculated, the output would be adjusted to 12mA, the 50% midpoint between 4 and 20mA.



FUNCTIONAL SUMMARY

	IN	OUT
#	1	1
TYPE	2 Wire	2 Wire
FORM	A	4-20mA

If the Average kW output mode(Electric mode only) is selected, the output for a selected demand interval --either 1, 2, 5, 10, 15, 30, or 60 minutes – is calculated continuously and the 4-20mA output represents the current interval's rolling average kW demand. The average Demand is updated every 15 seconds.

Programming of the PCL-2 is quick and easy using the SSI Universal programmer software through the PCL-2's USB port.

The PCL-2 uses a 12-bit Digital-to-Analog converter so resolution is 1/4096th of full scale. A bright red LED lamp indicates the input's status at all times. An additional Green LED indicates when the output is written to. Additional provisions are made to easily read the output's current level with a precision digital multimeter.

Typical applications include interfaces between utility metering devices and customer-owned energy management control systems, SCADA systems, recorders or programmable logic controllers. A +24VDC loop power supply is all that is necessary to implement the 4-20mA current loop. The PCL-2 has built-in transient and reverse polarity protection on the 4-20mA current loop output that eliminates the need for external protection.

PCL-2

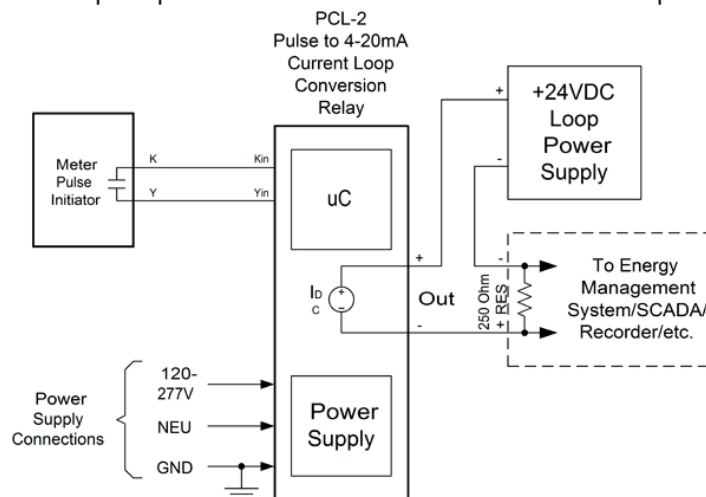



SPECIALTY DEVICES

PCL-2 PULSE-TO-CURRENT LOOP CONVERTER

SPECIFICATIONS

ELECTRICAL

Power Input:	120VAC; 208-277VAC. Burden: 10 MA. at 120 VAC
Input:	One KY Form A (2-wire) input with +13VDC wetting voltage compatible with dry-contact, open-collector transistor or open-drain FET transistor outputs.
Output:	One 4 – 20 mA current loop output. +5VDC maximum voltage output.
Output Impedance:	600 ohms maximum, 250 ohms typical
Loop to Control Isolation Voltage:	5000Vrms
Output Update Time:	Variable based on pulse width, up to 50 milliseconds max.
Maximum Input Pulse Rate:	20 pulses per second
Pulse value:	1 to 99999, in 1unit increments.
Full scale selection:	1-99999
Demand Averaging interval selection:	1, 2, 5, 10, 15, 30, 60 minutes.

MECHANICAL

Mounting:	Any position
Size:	3.50 inches wide, 7.20 inches high, 1.50 inches deep
Weight:	17 Ounces

TEMPERATURE

Temperature Range:	-38° C to +70° C, -36.4° F to +158° F
Humidity:	0 to 98% non-condensing

AVAILABLE OPTIONS

Input Voltages:	12VDC
-----------------	-------

PCL-2



SPECIALTY DEVICES

DCS-1 125VDC AUXILIARY POWER SUPPLY

DESCRIPTION

The DCS-1 Auxiliary Power Supply makes it possible to power virtually any SSI relay directly off of 125VDC station power. The DCS-1 power uses a switching power supply technology to efficiently power most standard SSI relays eliminating the need for an inverter. Because of the small size of the DCS-1, it replaces the power transformer on the host SSI relay and does not require any additional wiring or mounting space. A +12VDC output of the DCS-1 supplies the relay's power supply requirements as well as providing a wetting voltage to the meter.



The DCS-1 must be ordered as a factory-installed option by adding an “-SP2” suffix on the end of the product's part number. LS-Series relays are not available with the DCS-1 option.

DCS-1

SPECIFICATIONS

ELECTRICAL

Power Input:	125VDC
Maximum Output Voltage:	12VDC
Maximum Output Current:	200mA Max

MECHANICAL

Mounting:	Any position
Size:	1.5" wide, 1.0" high, 1.1" deep
Weight:	2 ounces

TEMPERATURE

Temperature Range:	-40° C to +85° C; -40° F to +185° F
Humidity:	0 to 98% non-condensing



SPECIALTY DEVICES

DCS-2 15-48VDC AUXILIARY POWER SUPPLY

DESCRIPTION

The DCS-2 Auxiliary Power Supply allows any SSI relay to be powered from a low voltage DC supply ranging from 15 to 48 VDC. The DCS-2 power uses a switching power supply technology to efficiently power most standard SSI relays eliminating the need for a step-down power transformer or other applicable power supply. The DCS-2's small size allows it to replace the power transformer on the host SSI relay and does not require any additional wiring or mounting space. A +12VDC output of the DCS-2 supplies the relay's power supply requirements as well as providing a wetting voltage to the meter.



The DCS-2 must be ordered as a factory-installed option by adding an "-SP13" suffix on the end of the product's part number. LS-Series relays are not available with the DCS-2 option.

DCS-2

SPECIFICATIONS

ELECTRICAL

Power Input:	15 - 48VDC
Maximum Output Voltage:	12VDC
Maximum Output Current:	500mA Max

MECHANICAL

Mounting:	Any position
Size:	1.5" wide, 1.0" high, 1.1" deep
Weight:	2 ounces

TEMPERATURE

Temperature Range:	-40° C to +85° C; -40° F to +185° F
Humidity:	0 to 98% non-condensing



SPECIALTY DEVICES

SPS-2 SOLAR POWER SUPPLY FOR PRL-1600 TRANSMITTER

DESCRIPTION

The SPS-2 Solar Power Supply provides a power source remote telemetry when a 120VAC or 12VDC power supply is not be available or when power by a renewable power source is desirable. The SPS-2 Solar Power Supply is a turn-key solution and includes everything you need to implement a solar-power supply:

- Solar Panel
- Solar Panel Mounting Bracket
- Charge Controller
- Interface Circuitry
- Battery
- NEMA 4X Enclosure 12"x10"x6"
- Internal Chassis and Mounting Hardware

A full battery charge results in about two weeks of "hold up" for a 10mA load with no additional sunlight. All components, except the solar panel, mount inside a 12" X 10" X 6" NEMA 4X high-impact ABS enclosure providing a rain-tight and dust-tight environment, pre-wired for a truly quick and convenient implementation. Installation is quick and easy. Simply mount the enclosure and solar panel on the supplied bracket. Make the connections of the solar panel and load to the Interface Circuit Board.

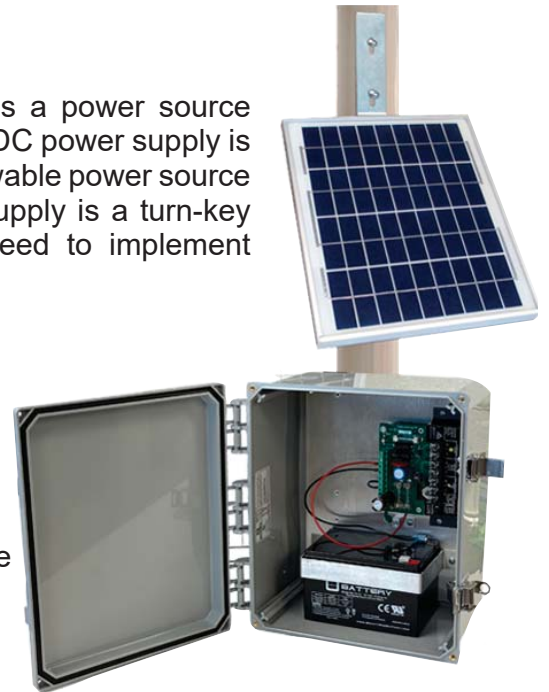

SPS-2



SPECIALTY DEVICES

SPS-2 SOLAR POWER SUPPLY FOR PRL-1600 TRANSMITTER

SPECIFICATIONS

ELECTRICAL

Power Input:	20 Watt Solar Panel
Output Voltage:	12 VDC
Charge Current:	500 mA Max
Battery Capacity:	15 Amp-hour
Battery Discharge Rate:	6 mA
Battery Recharge Time:	Approximately 6 hours

MECHANICAL

Mounting:	Any position for enclosure; Properly oriented for solar panel
Enclosure Material and Rating:	Fiberglass NEMA 4X
Enclosure Size:	12" wide, 10" high, 6" deep
Weight:	18 pounds

Environmental

Temperature Range:	-38° C to +70° C, -38.4° F to +158° F
Humidity:	0 to 98% non-condensing
Options:	5VDC Output at 1 amp max (SPS-1-5) 15VDC Output at 1 amp max (SPS-1-15)

SPS-2



SPS-5 SOLAR POWER SUPPLY

DESCRIPTION

The SPS-5 Solar Power Supply provides a power source remote telemetry when a 120VAC or 12VDC power supply is not be available or when power by a renewable power source is desirable. The SPS-5 Solar Power Supply is a turn-key solution and includes everything you need to implement a solar-power supply:

- Solar Panel
- Solar Panel Mounting Bracket
- Charge Controller
- Interface Circuitry
- Battery
- NEMA 4X Enclosure 16"x12"x6"
- Internal Chassis and Mounting Hardware



A full battery charge results in about two weeks of "hold up" for a 20mA load with no additional sunlight. All components, except the solar panel, mount inside a 16" X 12" X 6" NEMA 4X high-impact ABS enclosure providing a rain-tight and dust-tight environment, pre-wired for a truly quick and convenient implementation. Installation is quick and easy. Simply mount the enclosure and solar panel on the supplied bracket. Make the connections of the solar panel and load to the Interface Circuit Board.

SPS-5



SPS-5 SOLAR POWER SUPPLY

SPECIFICATIONS

ELECTRICAL

Power Input:	30 Watt Solar Panel
Output Voltage:	12 VDC
Charge Current:	500 mA Max
Battery Capacity:	34 Amp-hour
Battery Discharge Rate:	12 mA
Battery Recharge Time:	Approximately 6 hours

MECHANICAL

Mounting:	Any position for enclosure; Properly oriented for solar panel
Enclosure Material and Rating:	Fiberglass NEMA 4X
Enclosure Size:	16" wide, 12" high, 6" deep
Weight:	24 pounds

Environmental

Temperature Range:	-38° C to +70° C, -38.4° F to +158° F
Humidity:	0 to 98% non-condensing
Options:	5VDC Output at 1 amp max (SPS-5-5) 15VDC Output at 1 amp max (SPS-5-15)

All specifications are subject to change without notice.

SPS-5



SPS-6 SOLAR POWER SUPPLY

DESCRIPTION

The SPS-6 Solar Power Supply provides a power source remote telemetry when a 120VAC or 12VDC power supply is not be available or when power by a renewable power source is desirable. The SPS-6 Solar Power Supply is a turn-key solution and includes everything you need to implement a solar-power supply:

- Two Solar Panels
- Solar Panel Mounting Bracket
- Charge Controller
- Interface Circuitry
- Battery
- NEMA 4X Enclosure 16"x12"x6"
- Internal Chassis and Mounting Hardware



A full battery charge results in about two weeks of "hold up" for a 20mA load with no additional sunlight. All components, except the solar panel, mount inside a 16" X 12" X 6" NEMA 4X high-impact ABS enclosure providing a rain-tight and dust-tight environment, pre-wired for a truly quick and convenient implementation. Installation is quick and easy. Simply mount the enclosure and solar panel on the supplied bracket. Make the connections of the solar panel and load to the Interface Circuit Board.

SPS-6



SPS-6 SOLAR POWER SUPPLY

SPECIFICATIONS

ELECTRICAL

Power Input:	Two 30 Watt Solar Panels
Output Voltage:	12 VDC
Charge Current:	500 mA Max
Battery Capacity:	50 Amp-hour
Battery Discharge Rate:	12 mA
Battery Recharge Time:	Approximately 6 hours

MECHANICAL

Mounting:	Any position for enclosure; Properly oriented for solar panel
Enclosure Material and Rating:	Fiberglass NEMA 4X
Enclosure Size:	16" wide, 12" high, 6" deep
Weight:	30 pounds

Environmental

Temperature Range:	-38° C to +70° C, -38.4° F to +158° F
Humidity:	0 to 98% non-condensing
Options:	5VDC Output at 1 amp max (SPS-6-5) 15VDC Output at 1 amp max (SPS-6-15)

All specifications are subject to change without notice.

SPS-6



SPS-7 SOLAR POWER SUPPLY

DESCRIPTION

The SPS-7 Solar Power Supply provides a power source remote telemetry when a 120VAC or 12VDC power supply is not be available or when power by a renewable power source is desirable. The SPS-7 Solar Power Supply is a turn-key solution and includes everything you need to implement a solar-power supply:

- Two Solar Panels
- Solar Panel Mounting Bracket
- Charge Controller
- Interface Circuitry
- Battery
- NEMA 4X Enclosure 24"x16"x8"
- Internal Chassis and Mounting Hardware



A full battery charge results in about two weeks of "hold up" for a 20mA load with no additional sunlight. All components, except the solar panel, mount inside a 24" X 16" X 8" NEMA 4X high-impact ABS enclosure providing a rain-tight and dust-tight environment, pre-wired for a truly quick and convenient implementation. Installation is quick and easy. Simply mount the enclosure and solar panel on the supplied bracket. Make the connections of the solar panel and load to the Interface Circuit Board.

SPS-7



SPS-7 SOLAR POWER SUPPLY

SPECIFICATIONS

ELECTRICAL

Power Input:	Two 45 Watt Solar Panels
Output Voltage:	12 VDC
Charge Current:	500 mA Max
Battery Capacity:	75 Amp-hour
Battery Discharge Rate:	25 mA
Battery Recharge Time:	Approximately 6 hours

MECHANICAL

Mounting:	Any position for enclosure; Properly oriented for solar panel
Enclosure Material and Rating:	Fiberglass NEMA 4X
Enclosure Size:	24" wide, 16" high, 8" deep
Weight:	30 pounds

Environmental

Temperature Range:	-38° C to +70° C, -38.4° F to +158° F
Humidity:	0 to 98% non-condensing
Options:	5VDC Output at 1 amp max (SPS-7-5) 15VDC Output at 1 amp max (SPS-7-15)

All specifications are subject to change without notice.

SPS-7

SPS-9 SOLAR POWER SUPPLY



DESCRIPTION

The SPS-9 Solar Power Supply provides a power source remote telemetry when a 120VAC or 12VDC power supply is not be available or when power by a renewable power source is desirable. The SPS-9 Solar Power Supply is a turn-key solution and includes everything you need to implement a solar-power supply:

- One 160 Watt Solar Panel
- Solar Panel Mounting Bracket
- Charge Controller
- Interface Circuitry
- 150 Ah Battery
- NEMA 4X Enclosure 24"x20"x8"
- Internal Chassis and Mounting Hardware

A full battery charge results in approximately 12 days of "hold up" for a 500mA load with no additional sunlight. All components, except the solar panel, mount inside a 24" X 20" X 8" NEMA 4X high-impact ABS enclosure providing a rain-tight and dust-tight environment, pre-wired for a truly quick and convenient implementation. Installation is quick and easy. Simply mount the enclosure and solar panel on the supplied bracket. Make the connections of the solar panel and load to the Interface Circuit Board.



SPS-9



SPS-9 SOLAR POWER SUPPLY

SPECIFICATIONS

ELECTRICAL

Power Input:	One 160 Watt Solar Panels
Output Voltage:	12 VDC
Charge Current:	1.5A Max
Battery Capacity:	150 Amp-hour
Battery Discharge Rate:	500 mA
Battery Recharge Time:	Approximately 12 hours

MECHANICAL

Mounting:	Any position for enclosure; Properly oriented for solar panel
Enclosure Material and Rating:	Fiberglass NEMA 4X
Enclosure Size:	24" wide, 20" high, 8" deep
Weight:	125 pounds

Environmental

Temperature Range:	-38° C to +70° C, -38.4° F to +158° F
Humidity:	0 to 98% non-condensing
Options:	5VDC Output at 1 amp max (SPS-9-5) 15VDC Output at 1 amp max (SPS-9-15)

All specifications are subject to change without notice.

SPS-9



TYPICAL HOOKUPS

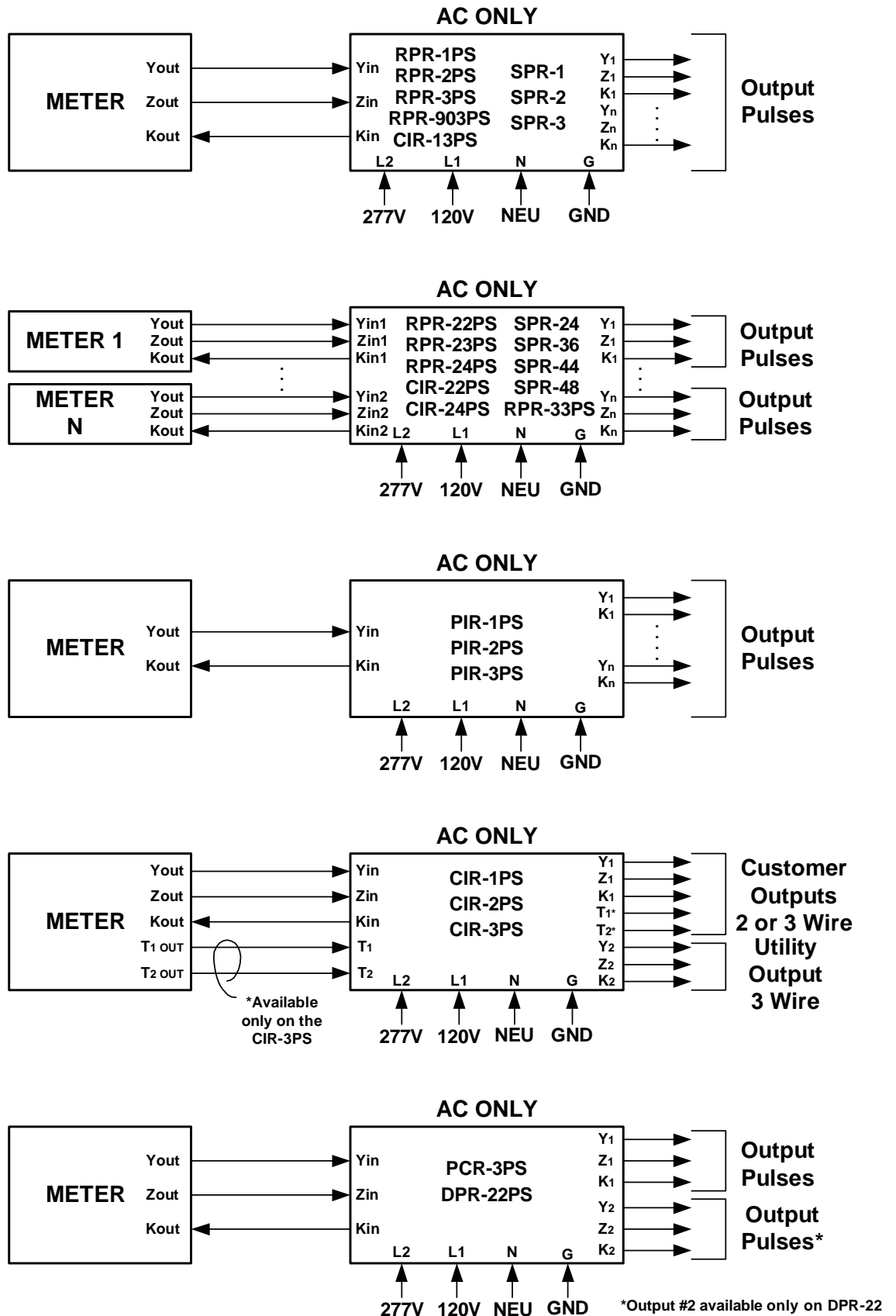



TYPICAL HOOKUPS

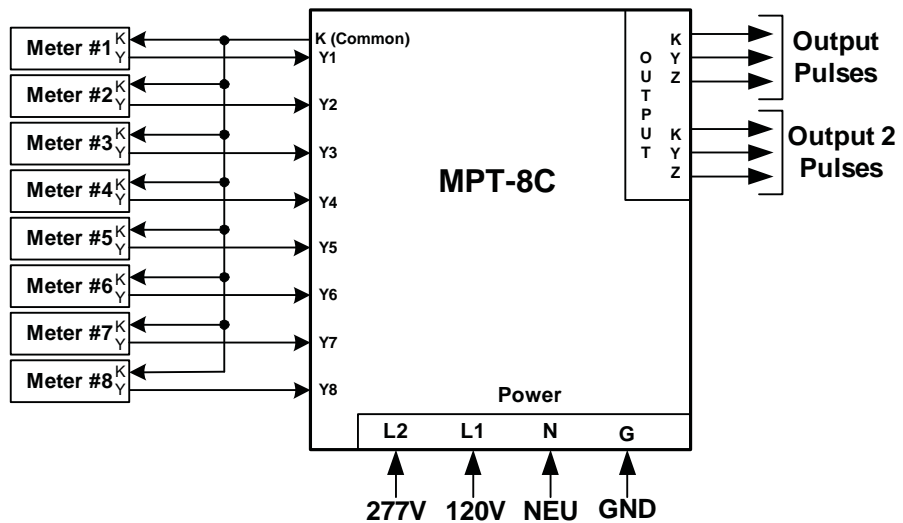
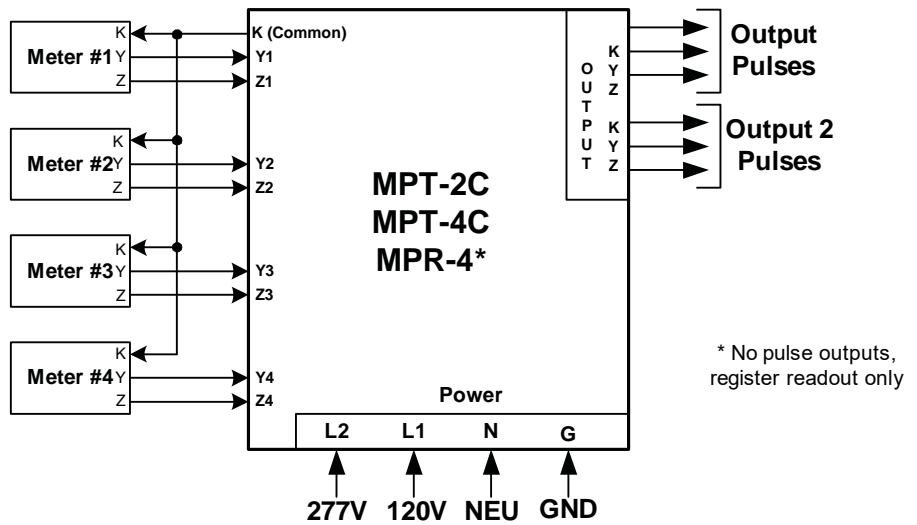
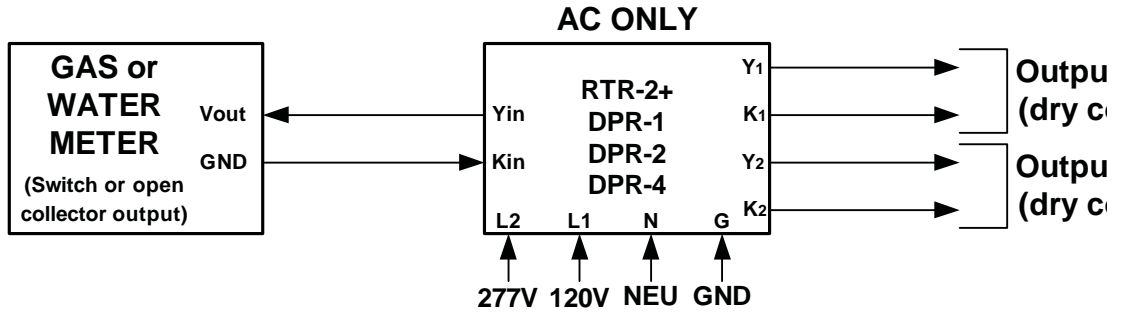



TYPICAL HOOKUPS

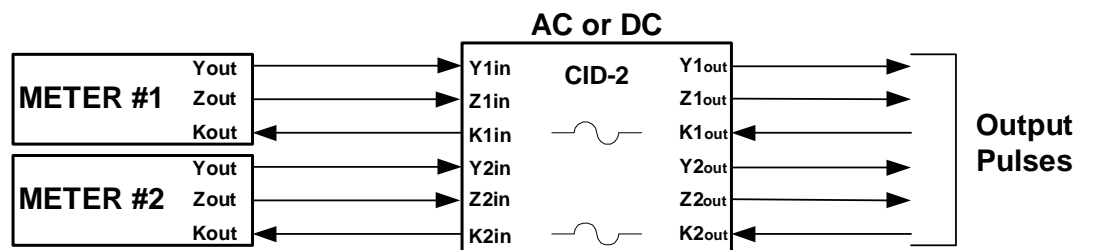
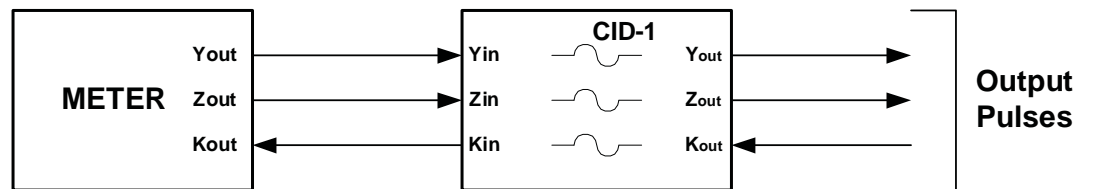
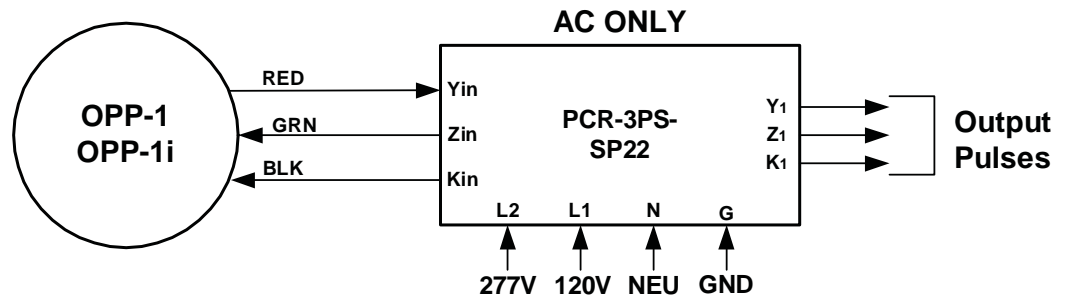
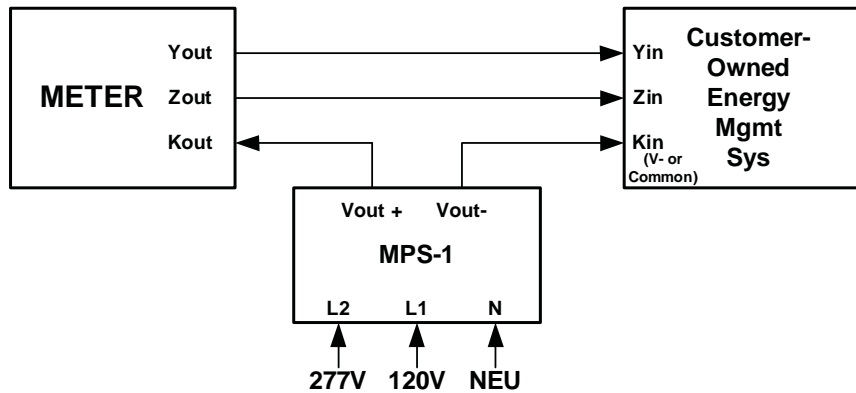
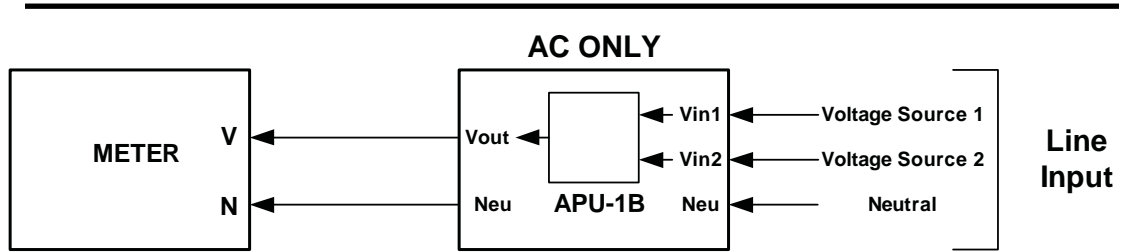



TYPICAL HOOKUPS

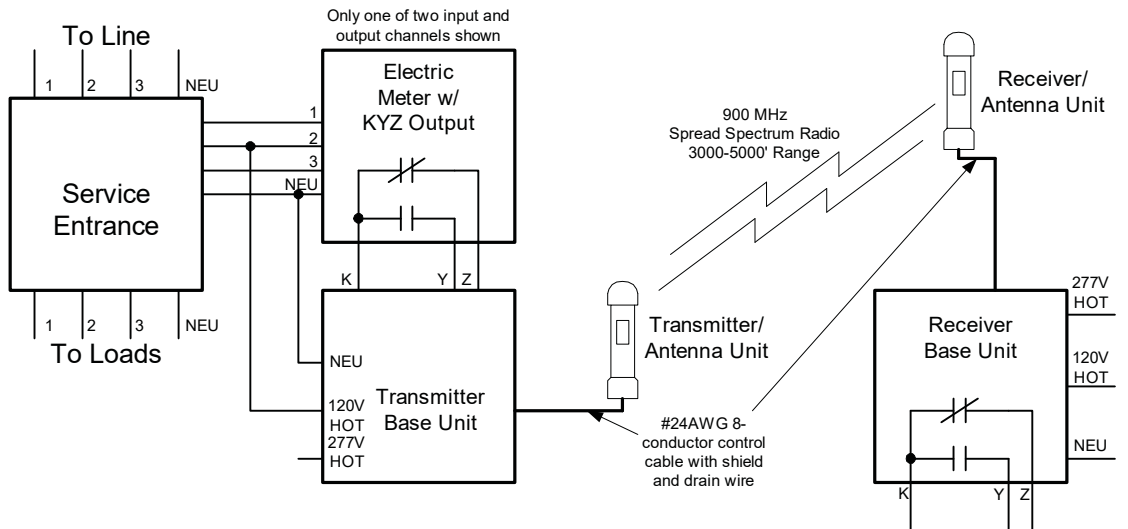
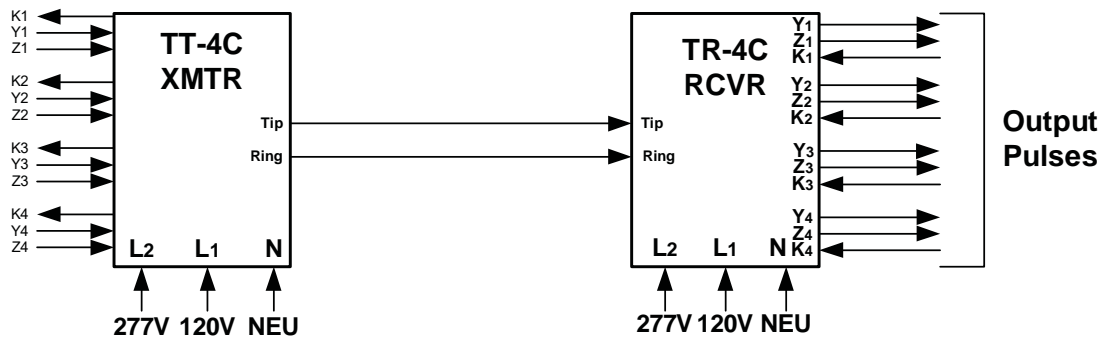
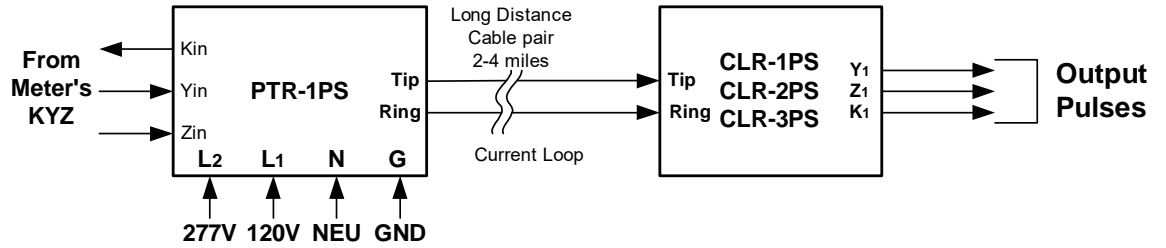

PRL-1200C Wireless Pulse Link System Diagram



TYPICAL HOOKUPS

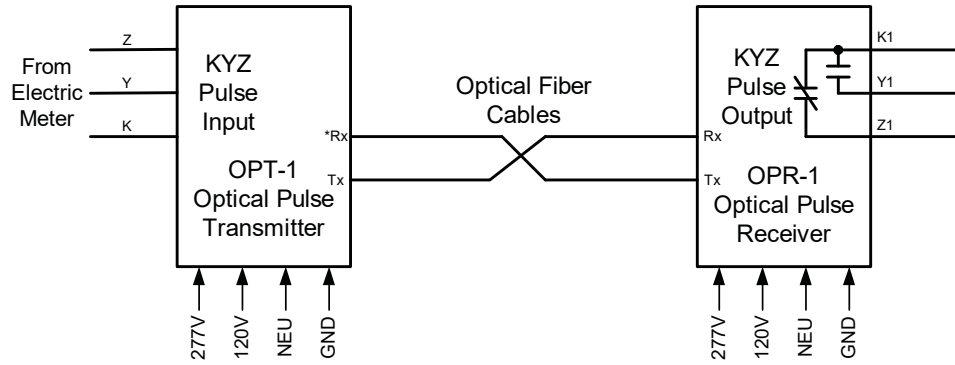

OPL Optical Pulse Link System Diagram
OPL-1B*, OPL-1C, OPL-4B, OPL-4C, OPL-8B, OPL-8C
 *Return fiber not used for the OPL-1B

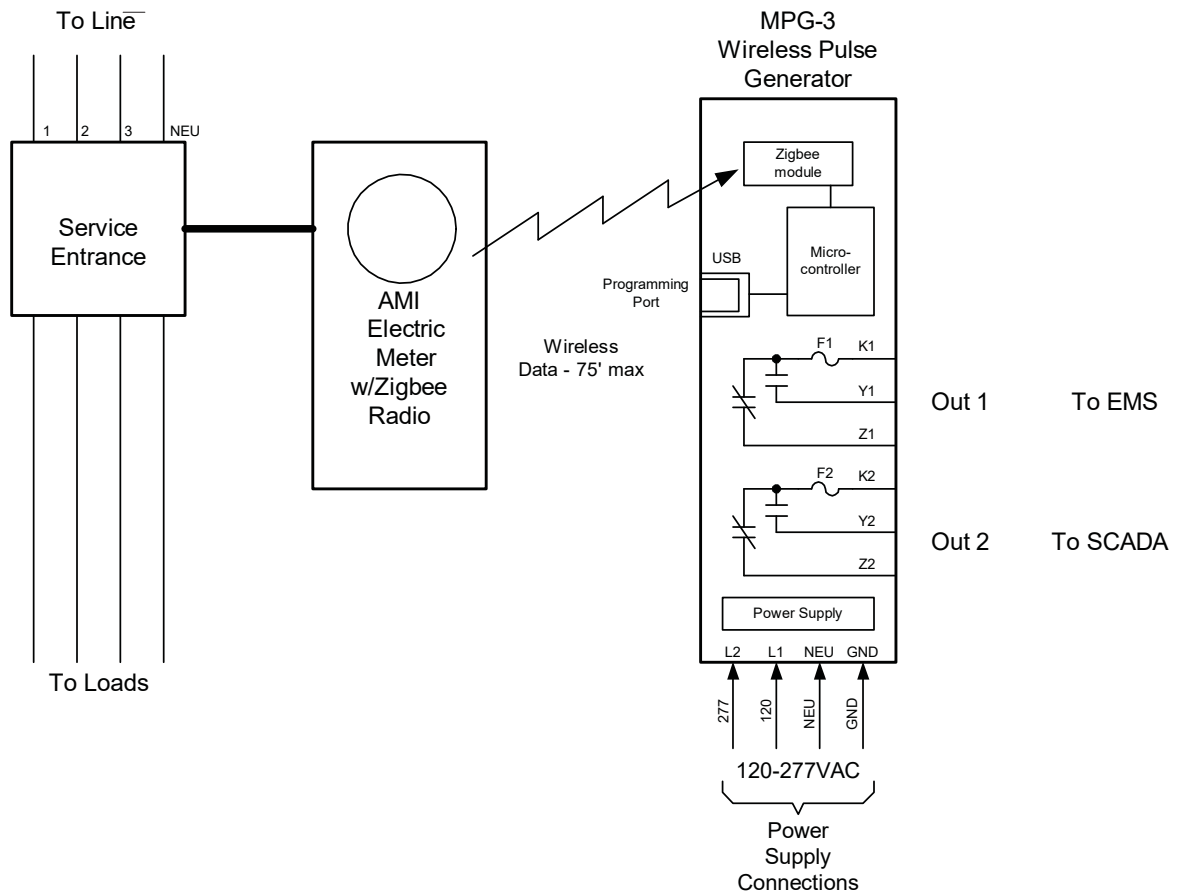

MPG-3 & MPG-3SC Zigbee Meter Pulse Generator



MECHANICAL DRAWINGS OF CASES

SSI Standard Large & Small Cases

SSI
Standard
Large
Case

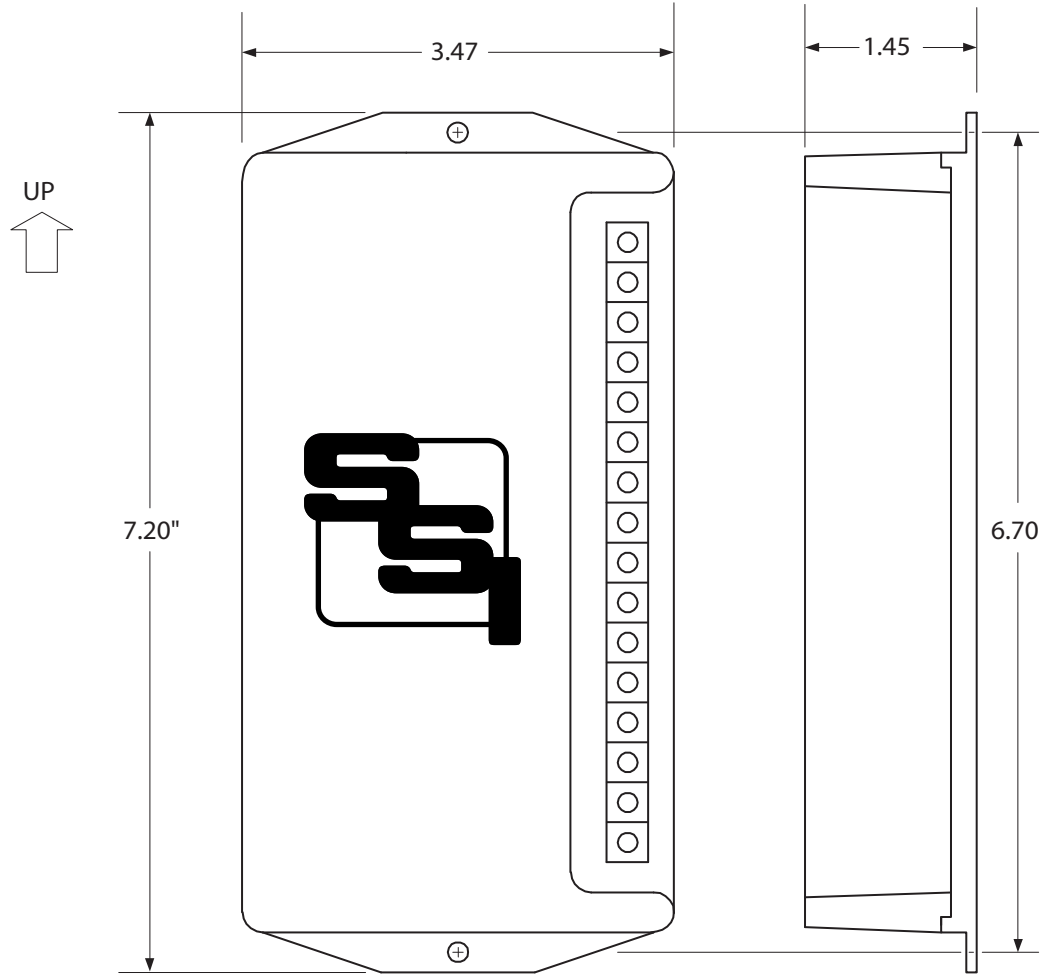

SSI
Standard
Small
Case

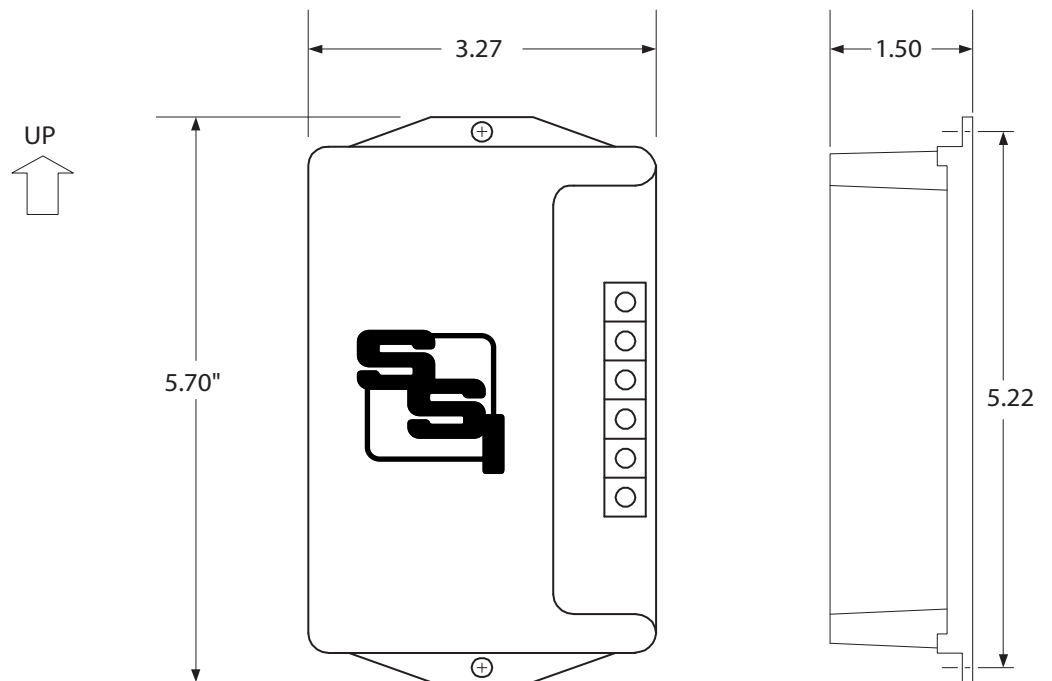



SOLID STATE INSTRUMENTS

A Product Family Owned by Radian Research

LIMITED WARRANTY

Solid State Instruments Division a Product Family Owned by Radian Research offers a limited warranty to the original owner of the product purchased that the product shall be free of defects resulting from faulty manufacturing for a period of one (1) calendar year from the date of purchase. SSI makes no warranties regarding the satisfactory performance, merchantability, or fitness for any particular purpose for the product. During the warranty period, SSI will, at its option, repair or replace, at no charge, any defective component or components, provided the defective product is returned freight prepaid to SSI. All returned products must be accompanied by a R.M.A. (return material authorization) number which may be obtained by calling SSI. Included with the product must be a clear description of the nature of the failure along with any supporting data or test information.

SSI's sole obligation under this limited warranty is limited to the repair or replacement of defective product and SSI shall not, in any event, be liable to the purchaser, his assignee, or any third party, for any incidental or consequential damages, of any kind resulting from the use or possession of these products.

Please contact us at 765-449-5500 if you have questions, need product support or would like to request an RMA number.

SHIPPING

All freight costs are F.O.B. Lafayette, IN U.S.A. Unless otherwise requested freight will be prepaid and added to the invoice. Shipments will, unless otherwise requested, be made by UPS Ground, FedEx Ground (surface shipment) or USPS Postal Service depending upon size, weight and distance, at BAC/SSI's option.

TERMS OF SALE

Merchandise is sold to firms upon satisfactory credit approval on a Net 30 basis. Firms which are not approved or that need special terms should contact the factory upon ordering. A 1.5% per month finance charge of the unpaid balance will be added to all outstanding balances in excess of 30 days old and unpaid. All returned merchandise shall be subject to a 15% restocking charge. All purchase orders are required to be submitted in writing with a valid purchase order number and authorized signature of an authorized buyer. We accept Visa and MasterCard credit cards. Purchaser will bear all costs associated with a disputed credit card charge which results in action from BAC's merchant account provider, otherwise known as "chargebacks".



SOLID STATE INSTRUMENTS

A Product Family Owned by Radian Research

*3852 Fortune Drive,
Lafayette, IN 47905
Ph: (765) 449-5500
Fax: (765) 448-4614*

*www.radianresearch.com
sales@radianresearch.com*