

SPR-44 PULSE ISOLATION RELAY

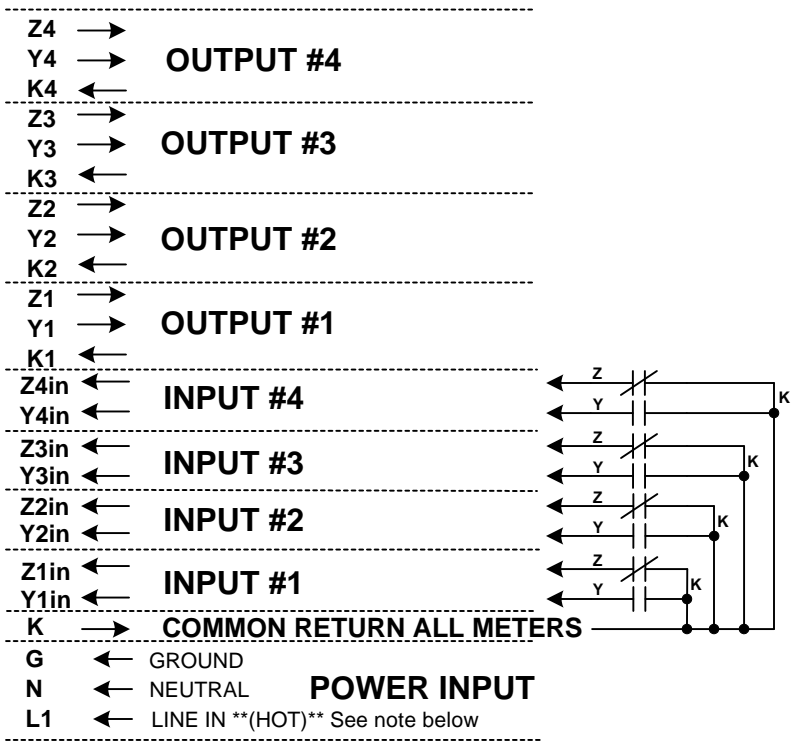
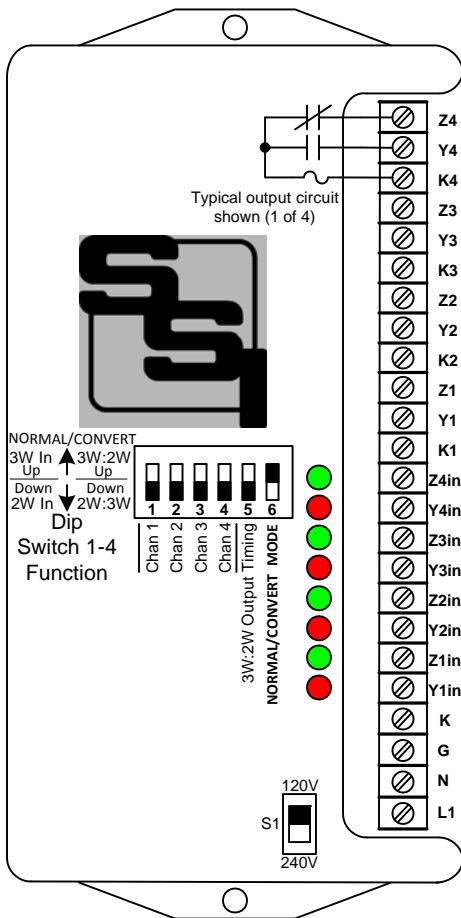

MOUNTING POSITION - The SPR-44 may be mounted in any position.

POWER INPUT - The SPR-44 is powered by an AC voltage of between 90 and 300 volts. Connect the power supply's "HOT" lead to terminal **L1**. Connect the AC line's "neutral" wire to the **N** terminal. Connect electrical system ground to the **G** terminal. For use with 120VAC, put switch **S1** in the **UP** position. For use on 208 thru 277VAC, put switch **S1** in the **DOWN** position. If Neutral does not exist at the meter, connect both NEU and GND to Ground.

PULSE INPUTS - Connect the K terminal of each meter supplying pulses to the SPR-44's **Kin** terminal. Form C Input: Connect the **Yin** and **Zin** input terminals to the Y and Z terminals of the respective meters as shown. Form A Input: Connect the **Yin** input terminal to the Y terminal of the respective meter.

OPERATIONAL MODE SELECT - The SPR-44 may be set to operate in either the **Normal** pulse isolation relay mode or the **Pulse Conversion** mode. All four channels operate in the same mode depending on the position of Dip Switch #6. When Dip Switch #6 is **DOWN**, the SPR-44 is in the Normal "pass-thru" or non-conversion mode. If Dip Switch #6 is **UP**, the SPR-44 is in the Pulse Conversion mode. See Page 2 for Pulse Conversion mode operation.

INPUT CONFIGURATION SELECTION - In Normal mode, the SPR-44's four channels may be individually configured as either 2-Wire to 3-Wire inputs (Form A to Form C). Dip Switch 1 selects the input configuration for CHANNEL #1. Dip Switch 2 sets the input configuration for CHANNEL #2, Etc. Place the Dip Switch in the **UP** position for a 3-Wire mode or in the **DOWN** position for 2-Wire mode.



SOLID STATE INSTRUMENTS

a division of Brayden Automation Corp.
 6230 Aviation Circle, Loveland, Colorado 80538
 Phone: (970)461-9600 Fax: (970)461-9605
 E-mail: support@solidstateinstruments.com

OUTPUTS - Four three-wire isolated outputs are provided on the SPR-44, with output terminals K1, Y1 & Z1; K2, Y2, & Z2; K3, Y3 & Z3; and K4, Y4 & Z4. Outputs are rated at 250VAC/VDC @ .1 Amp and total power dissipation of 850mW per output. MOV Transient voltage suppression for the contacts of the solid state relays is provided internally. Each relay output follows its respective input number.

FUSES - The fuses are type 3AG (AGC) and may be up to 1/10th Amp in size. Four 1/10 Amp fuses (F1-F4) are supplied standard with the unit unless otherwise specified.

Pulse Conversion Mode

PURPOSE - The SPR-44's pulse conversion mode is used for converting a 2-Wire (Form A) input pulse to a 3-Wire (Form C) output pulse, or visa versa, while maintaining a constant pulse value. The Pulse Conversion mode applies to all four inputs and outputs if DIP Switch #6 is in the **UP** position. Once the SPR-44 is in the Pulse Conversion mode, DIP Switches #1 through #4 configure the conversion function. Each channel's DIP Switch individually configures the corresponding channel for a 2-wire (A) input to 3-Wire (C) output, OR for a 3-wire (C) input to a 2-wire (A) output.

All four channels operate in the same mode depending on the position of Dip Switch #6. When Dip Switch #6 is **DOWN**, the SPR-44 is in the Normal "pass-thru" or non-conversion mode. If Dip Switch #6 is **UP**, the SPR-44 is in the Pulse Conversion mode.

INPUT CONFIGURATION SELECT - In Pulse Conversion mode, the four channels may be individually configured as either 2-Wire to 3-Wire inputs (Form A to Form C). Dip Switch #1 selects the input/output function for CHANNEL #1. Dip Switch 2 sets the input/output function for CHANNEL #2, Etc. Place the Dip Switch in the **DOWN** position for a 2-Wire input to 3-Wire output conversion or in the **UP** position for 3-Wire input to 2-Wire output conversion.

OUTPUT TIMING in FORM A MODE - When the SPR-44 is in 3-Wire to 2-Wire Conversion mode (Form C to Form A) Dip Switch #5 sets the pulse output duration of the output pulse. Place the Dip Switch #5 in the "UP" position for a 100mS output pulse or in the "DOWN" position for a 50mS output pulse.

SPR-44 Wiring Diagram

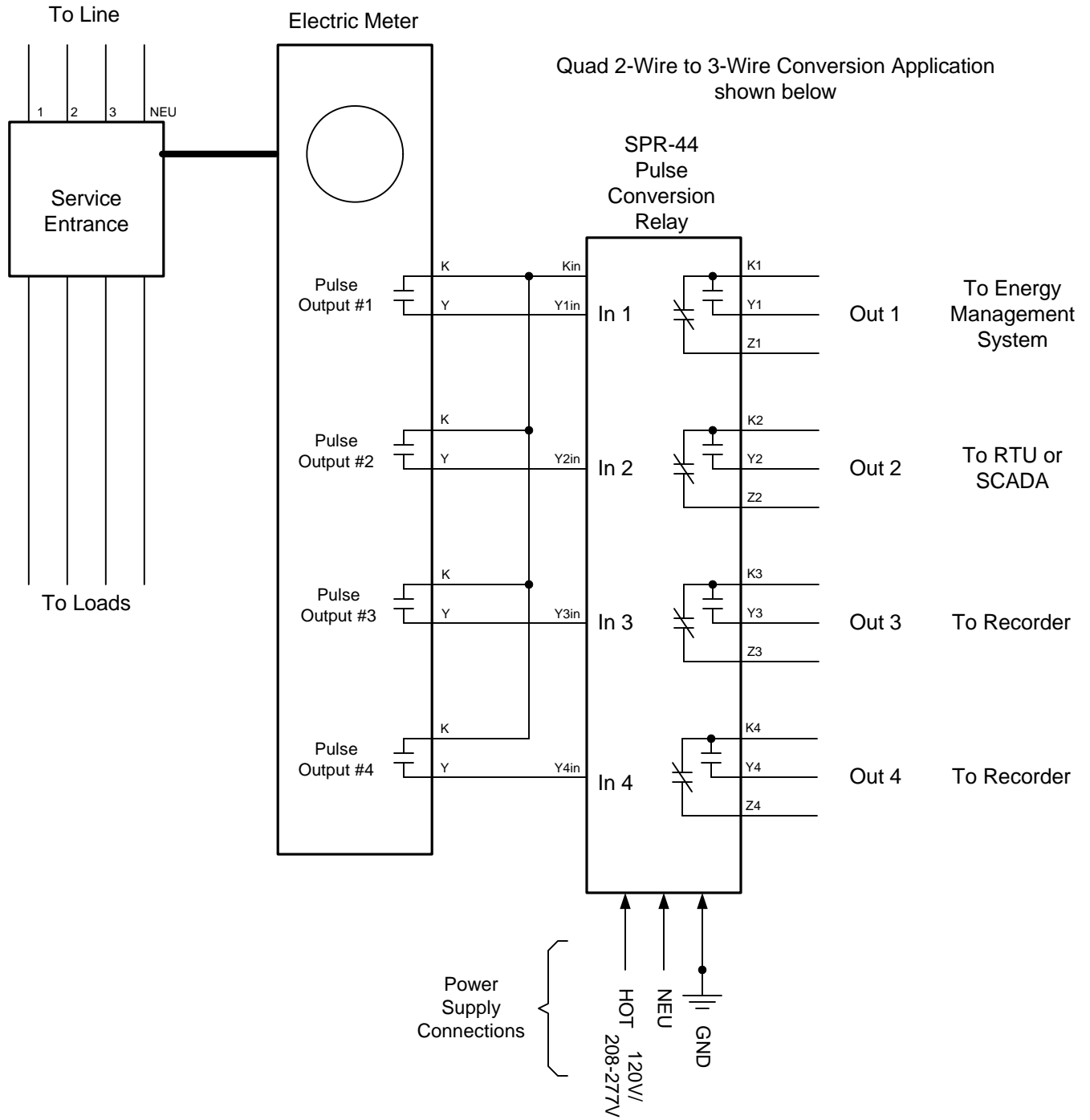

SPR-44WiringDiagram.vsd

| | | | |
|---|--|-----------|------|
| SPR-44 Repeating Pulse Relay Wiring Diagram | | REVISIONS | |
| | | NO. | DATE |
| DATE ORIGINAL | | SCALE | |
| 08/22/2018 | | N/A | |
| LATEST REVISION | | JOB NO. | |
| | | CHECKED | |
| | | DRAWN | |
| | | WHB | |

Brayden Automation Corp./
Solid State Instruments div.
 6230 Aviation Circle
 Loveland, CO 80538
 (970)461-9600
 (970)461-9205 fax
www.solidstateinstruments.com

WORKING WITH THE SPR-44 RELAY

CONVERSION MODES: The SPR-44 Pulse Conversion allows a 3-Wire to 2-Wire OR 2-Wire to 3-Wire pulse conversion. Below are timing diagrams which illustrate the SPR-44's function in each mode.

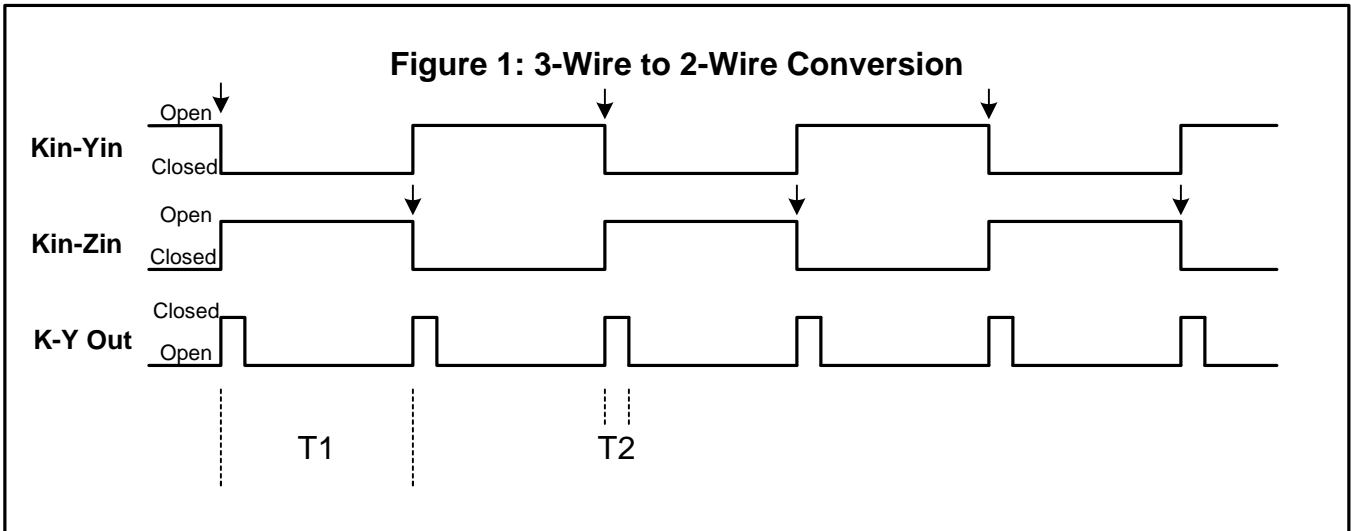

In the 3-Wire to 2-Wire conversion mode (shown above), each closure between Kin and Yin, and alternately between Kin and Zin causes the SPR-44 to generate an output pulse (closure of the K to Y output terminals) of 50 or 100mS depending on the position of Dip Switch #5. An input of less than 20mS is ignored since it is most likely to be noise. An input of 20mS or longer is classified as a valid input. The input pulse duration (T1) must be greater than approximately 110mS since it must be longer than the output pulse width (T2) which is fixed at 100mS. This results in a maximum input pulse rate of 9 pulses per second.

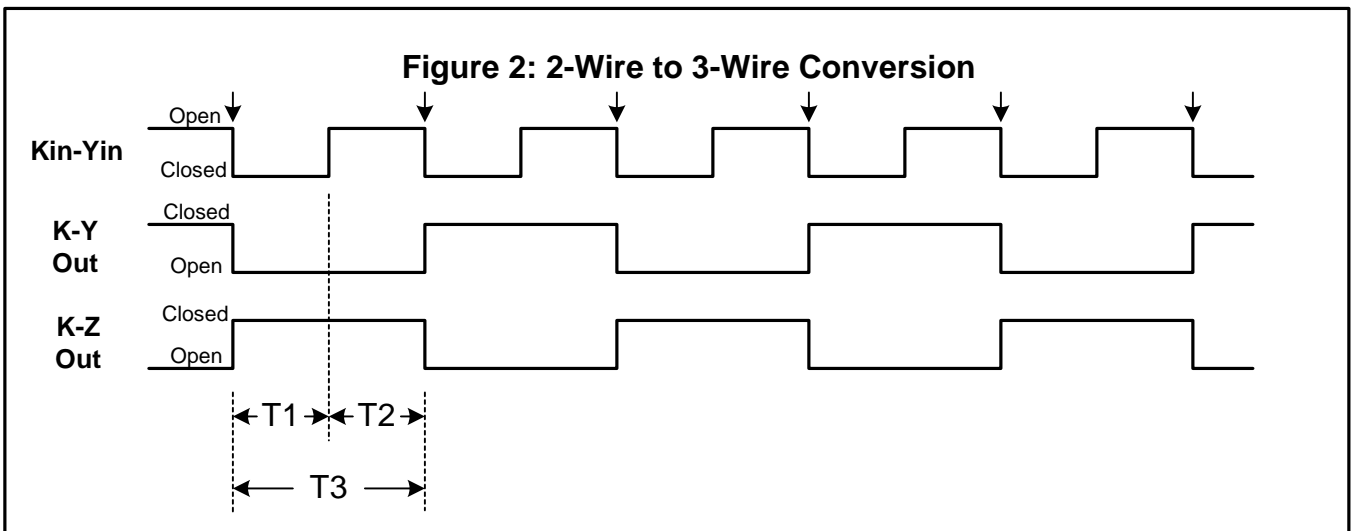

In the 2-Wire to 3-Wire conversion mode, each closure between Kin and Yin (as shown above by the arrows) causes the SPR-44 to generate an output pulse - a closure of the K to Y (and alternately K to Z) output contact terminals. The open state (T2) of the Kin and Yin terminals (absence of connection) results in no action. An active input state (T1) must be 20mS or longer to be classified as a valid input. Otherwise the pulse is ignored. Each output pulse's duration (T3) is equal to T1 + T2. Maximum input pulse rate in this mode is 20 pulses per second.