

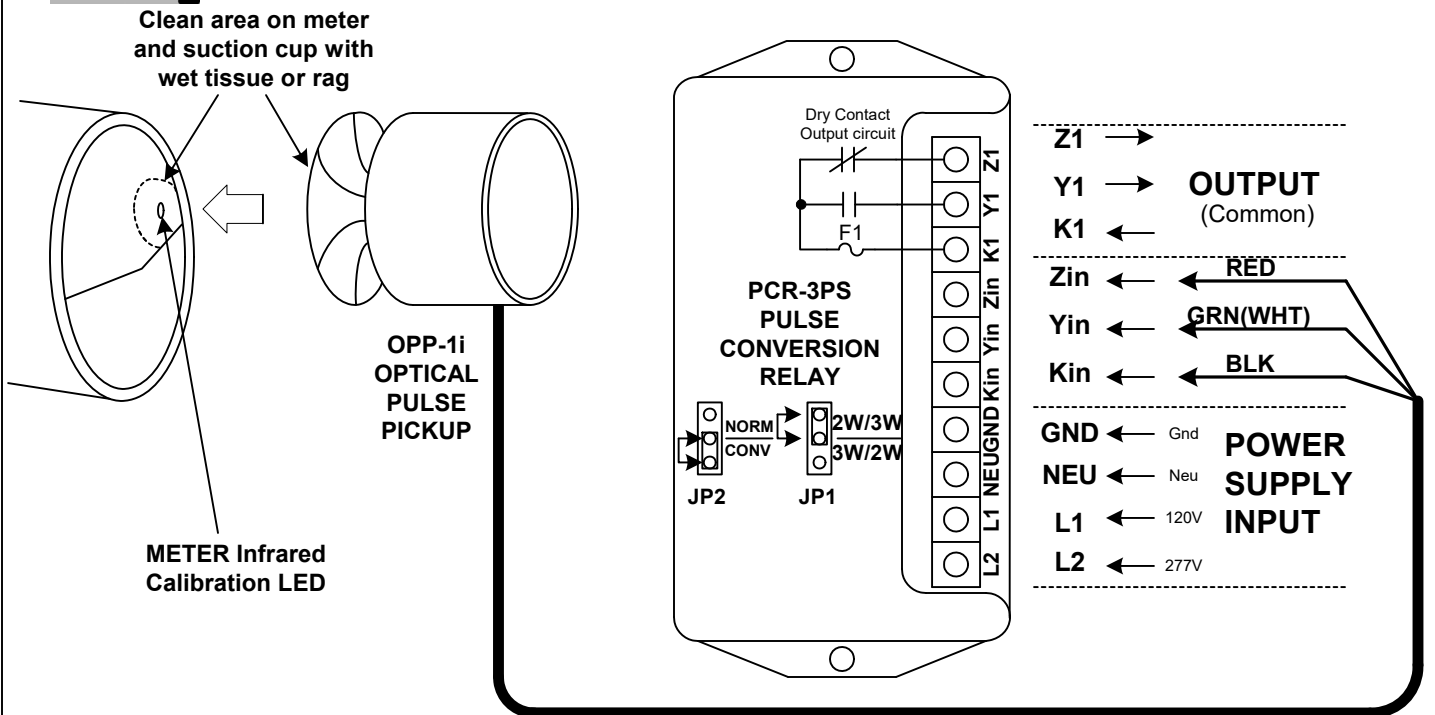

INSTRUCTION SHEET

OPP-1i OPTICAL PULSE PICKUP



GENERAL - The OPP-1i is an optical pulse pickup that uses the meter's infrared calibration pulse to read energy consumed by the building on which the meter is mounted. The OPP-1i uses a PCR-3 relay for power, pulse conversion and output isolation. Each time the meter's optical calibration pulse flashes, the OPP-1i picks up the flash and converts it to one Form C (3-wire) pulse on the PCR-3PS' output. Pulses may be counted for energy consumption, or timed to calculate demand. Contact SSI for more information if required.

MOUNTING - The OPP-1i mounts on the meter's face directly in line with the Infrared calibration LED, snapping into place using the suction cup. Orient the center of the OPP-1i's suction cup with the meter's calibration LED.

POWER INPUT - The PCR-3PS is powered by an AC voltage of between 90 and 300 volts. For 120VAC line operation, connect the 120VAC HOT lead to the L1 terminal. For 208 to 277VAC line operation, connect the 208-277VAC HOT lead to the L2 terminal. Connect the neutral lead to the NEU terminal. Connect GND to ground.

INPUT - Connect the OPP-1i as shown above to the PCR-3PS' input terminal. Connect the black wire to the "Kin" terminal, the green wire to the "Yin" terminal and the red wire to the "Zin" terminal. Maximum distance between the OPP-1i and the PCR-3PS input is 25 feet.

OUTPUT - One 3-wire isolated "dry-contact" output is provided on the PCR-3PS with output terminals K1, Y1 and Z1. Internal MOV transient voltage suppression for the solid-state relay is provided.

FUSE - The fuse is type 3AG and may be up to 1/2 Amp in size. A 1/2 Amp fuse (F1) is supplied standard.

OPERATION - Jumper JP1 must be in the **top** position, and JP2 must be in the **bottom** position. For each input pulse from the OPP-1i, the output will change state, alternately giving continuity between K1 and Y1 on the first pulse, then K1 and Z1 upon the next pulse. This system is designed for Itron Sentinel meters that continuously output the calibration pulse using this infrared LED. Care should be taken to insure that high ambient light conditions do not affect the OPP-1i's ability to see the Infrared pulse. Shade the meter if necessary from direct sunlight with a dark cloth or other such opaque material.



SOLID STATE INSTRUMENTS

by Radian Research, Inc

3852 Fortune Dr, Lafayette, IN 47905

Phone: (765) 449-5576

Mail: technicalsupport@radianresearch.com