

PRL-1600CR C Series Wireless Pulse Link System Technical Manual

Revision: C1
Date: 10/08/2024

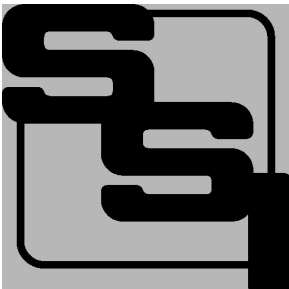

Solid State Instruments

by Radian Research, Inc

3852 Fortune Dr, Lafayette, IN 47905

Phone: (765) 449-5576

Mail: technicalsupport@radianresearch.com

PRL-1600CR Wireless Pulse Link System

Table of Contents

Introduction	3
Pulse Link System Design and Planning	4
Considerations for a Successful Installation	5
PRNT-1600C Pulse Radio Transmitter	6
PRT-16C Transmitter Base Unit	9
PRNR-1600C Pulse Radio Receiver	11
PRR-16CR Receiver Base Unit	13
Using the 2-Wire (Form A) or 3-Wire (Form C) Modes	16
Transmitter and Receiver Pairing Procedure	17
System Diagram	18
Troubleshooting and Tech Support	19
Appendices	21
FCC/IC Notices	24

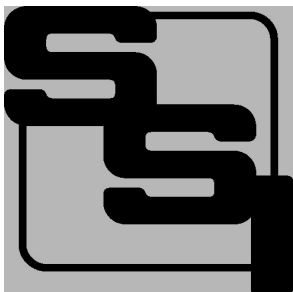

Solid State Instruments

by Radian Research, Inc

3852 Fortune Dr, Lafayette, IN 47905

Phone: (765) 449-5576

Mail: technicalsupport@radianresearch.com

Introduction

The PRL-1600CR Pulse Radio Link is a Transmitter and Receiver system that wirelessly sends up to four channels of KYZ pulses from the transmitter to a paired receiver. The short-hop PRL-1600CR has a range of up to 5,000 feet depending on site topography and solves the problem of getting pulses across parking lots, vacant lots, roads, railroad tracks or other obstacles. With the PRL-1600CR, you're now able to connect real-time KYZ pulses from 2 Form C pulse channels or 4 Form A pulse channels. Pulses from each meter output are independently outputted on one of the four channels in the receiver. The PRL-1600CR eliminates trenching or other costly methods of getting wires strung between each meter and the destination device as well as providing superior isolation against transients that could be induced in a long cable run. Additionally, ground rise problems are eliminated since there is no electrical connection between the two devices.

The PRL-1600CR Radio Pulse Link system consists of one PRT-1600C Transmitter and one PRR-1600CR Receiver. The system uses Frequency Hopping Spread Spectrum (FHSS) technology to communicate on 64 frequencies between 902 to 927MHz, using one of 6 hop sequence "channels", and allows unlicensed operation by the user, allowing multiple systems to operate in the same radio airspace. Nominally, the PRL-1600CR will transmit pulses between 2,500 and 5,000 feet in an unobstructed line-of-sight configuration but may go farther depending on optimal site conditions.

PRT-1600C TRANSMITTER

The **PRT-1600C** Transmitter consists of the following:

- ***PRNT-1600C** Pulse Radio Transmitter/Antenna Unit

- ***PRT-16C** Pulse Transmitter Base Unit

The PRT-1600C Transmitter receives pulses from a meter's KYZ pulse initiator and sends them to the PRR-1600 Receiver unit wirelessly. Each 10 second interval, the number of pulses received from the meter's pulse KYZ initiator, is transmitted to the Receiver upon the next transmission cycle. The Receiver will then generate the correct number of pulses at KYZ outputs, over the next 10 seconds. The PRNT-1600C Transmitter/Antenna Unit contains the transceiver radio, a microcontroller and all the circuitry and software to communicate with the Receiver. The PRT-16C Base Unit contains the power supply, termination points, and has a built-in low voltage transformer-isolated power supply generating a +13VDC sense (wetting) voltage. The sense voltage is connected to meter's dry-contact KYZ pulse initiator. The PRT-1600 Transmitter is capable of operating on supply voltages of 120 or 208-277VAC. In addition to line power, it can be operated with batteries or a solar power supply such as Solid State Instruments' SPS-2 Solar Power Supply by using the PRT-16CS 12VDC Transmitter Base Unit. Transmitter boards are **GREEN**.

PRR-1600CR RECEIVER

The **PRR-1600CR** Receiver consists of the following:

- ***PRNR-1600C** Pulse Radio Receiver/Antenna Unit

- ***PRR-16CR** Pulse Receiver Base Unit

The PRR-1600CR contains the transceiver radio, a microcontroller and all the circuitry and software to receive pulses from the Transmitter and output them on one of four output channels. The PRR-16CR Base Unit contains the power supply, output relays and termination points where all connections are made. Four output channels are available, and can be configured as 4 Form A or 2 Form C. Each output channel contains one Form A (2-Wire) Solid State output. The Receiver/Antenna unit is intended to be mounted outdoors, in a direct line-of-sight with the Transmitter/Antenna unit. It cannot operate if obstructed by trees, metal poles, buildings or other objects. The Receiver Base Unit is designed to mount indoors, or inside an existing control enclosure suitable for the application. The Base and Radio/Antenna Units are connected together by means of an 8-conductor, #24AWG 4 twisted pair shielded control cable. It is important for noise immunity and error-free communications between the Base and Transceiver that shielded control cable be used. The PRR-1600 is capable of operating on supply voltages of 12VDC or 15-48VDC. Other power supply voltages are available upon special order. Receiver boards are **RED**.

PRL-1600CR SYSTEM DESIGN AND PLANNING

SYSTEM CONFIGURATION - The PRL-1600C can be used in one of two configurations: 4 Form A pulse channels or 2 Form C pulse channels. The entire system operates in either one mode or the other. They cannot be mixed.

Form A Configuration: The Form A configuration will transmit four 2-Wire (KY) pulse channels.

Form C Configuration: The Form C configuration will transmit two 3-wire (KYZ) pulse channels.

Determine the desired mode for the system.

Dip Switch DS1's switches #1 through #3 set the channel # or "hop" sequence. Both the PRT Transmitter and the PRR Receiver units must be set to the same channel or hop sequence. See Table 1 at left.

Table 1

Channel #	DS1.1	DS1.2	DS1.3
1	DN	DN	DN
2	DN	DN	UP
3	DN	UP	DN
4	DN	UP	UP
5	UP	DN	DN
6	UP	DN	UP
5	UP	UP	DN
5	UP	UP	UP

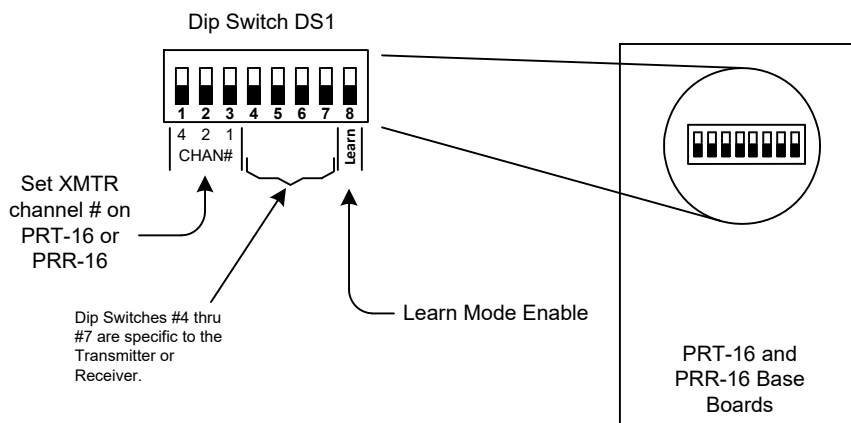

SYSTEM CHANNEL - The PRL-1600C System operates on one of 6 hop sequence channels. Each channel consists of 50 unique frequencies out of 64 frequencies available in the 902MHz to 927MHz range. This allows enhanced reliability since RF transmissions are transmitted on one of the channel frequencies until they are received by the receiver. Set the Transmitter and the Receiver to the same channel number. Multiple PRL-1600C systems can operate in the same radio airspace by each system having a different channel number. Once you have determined the channel # that you will use, configure Dip Switch S1's switches #1 through #3 on the PRT-16C or 16CS Transmitter Base board and the PRT-16C Receiver Base board. Table 1 shows the dip switch combinations for each channel.

SYSTEM OPERATING MODE - The PRL-1600C System operates in a near real-time operational mode, where the PRT-1600C Transmitter transmits one transmission every 10 seconds with the pulse data it has received from the meter over the previous 10-second period. When the transmission is received by the PRR-1600C Receiver, pulses are generated over the next 10-second period. Additional error checking and pulse verification are used in this mode for the highest possible accuracy. Packet Transmissions and Receptions are visually indicated with LEDs on both base and radio/antenna units.

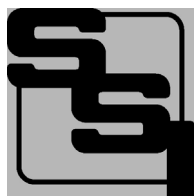

SOLID STATE INSTRUMENTS

by Radian Research, Inc

3852 Fortune Dr, Lafayette, IN 47905

Phone: (765) 449-5576

Mail: technicalsupport@radianresearch.com

CONSIDERATIONS FOR A SUCCESSFUL INSTALLATION

GENERAL - The PRL-1600CR System is designed to provide mirror-image pulses from the transmitter to the receiver. This is important for Peak Demand Control since the KW demand is determined by timing the pulses. The greater the time between pulses, the lower the demand. Conversely, the shorter time between pulses, the higher the demand. Every effort is made in the PRL-1600CR to be a "virtual copper wire" and make the pulses coming out of the receiver the same pulse width as the pulses going into the transmitter.

The PRL-1600CR System is designed for concentrated RF environments where there is a significant amount of RF traffic on these or adjacent frequencies. Pulses are collected by the transmitter for 10 seconds. The number of pulses received in the immediate 10-second period is then sent to the receiver which duplicates those pulses over the next 10 seconds. All output pulses are thus delayed by 10 seconds. The benefit of this method is significantly reduced RF traffic and high-accuracy due to the expanded error checking and pulse count "true up".

APPROPRIATE PULSE CONSTANT - It is important to properly program the Pulse Constant of the meter such that there are no more than 2 pulses per second at the peak KW demand of the building or facility. Pulses faster than this may be lost. If a high pulse rate is unavoidable from the meter and cannot be slowed down, consider one of the DPR Dividing Pulse Relays (DPR-1, DPR-2 or DPR-4) from Solid State Instruments.

SHIELDED CONTROL CABLE - ***Shielded Control cable must be used between each radio and base unit.***

MINIMUM PULSE WIDTH - Make sure that the pulse width coming from the meter is at least 100mS in duration.

LINE OF SIGHT - Make sure that you have the Receiver Radio/Antenna Unit in a location where the Transmitter's Radio/Antenna unit can "see" it with a wide field of view. The PRL-1600CR is a Line-Of-Sight system, and the transmitter must have uninterrupted and unrestricted sight with the receiver radio at all times. Make sure that there are no trees, metal buildings, light poles, rail cars, trucks, buses or any other obstruction that gets in the line-of-sight between the transmitter and receiver at any time. Interruptions in the line-of-sight may cause pulses to be lost. Generally speaking, the PRL-1600CR will not transmit through concrete, concrete block or masonry walls. We can't stress this enough: The RF path must be line-of-sight!

HEIGHT - Mount the Transmitter and Receiver Radio/Antenna units up off the ground as high as reasonably possible, 14' minimum, to eliminate RF reflections, improve reception and transmission distance. The higher the transmitter is off the ground, the longer the transmission distance and the more reliable the reception by the receiver.

MOUNTING: If mounting the Receiver Radio/Antenna unit on the side of a metal building, make sure that the antenna in the Radio/Antenna unit is mounted at least 6.1" away from the metal siding. Use the mounting brackets supplied with the PRL-1600CR to get this distance. You may have to rotate the board to insure that the antenna is not closer to the metal surface than 6.1", since the antenna is not exactly in the center of the board as well as the board being mounted in an off-set fashion. If the antenna is closer than 6.1", the signal may be corrupted and transmissions may be affected. Rotate each radio/antenna units' board if possible so the board is perpendicular to the transmitter or receiver on the opposite end of the system, keeping the antenna 6.1" away from any metal.

INTERFERENCE - The PRL-1600C® is a Frequency-Hopping Spread Spectrum system that communicates on 50 of 64 designated frequencies. It may or may not work in substations or in other areas where high-power energy and magnetic fields exist, or where RF energy may jam the signal. The electromagnetic field around high voltage conductors may cause enough interference so as to keep the system from transmitting correctly or may significantly reduce the range of the system. It has been reported that other high-power RF transmitters mounted within close proximity can jam or corrupt the signal even though they are not using the same frequencies.



SOLID STATE INSTRUMENTS

by Radian Research, Inc

3852 Fortune Dr, Lafayette, IN 47905

Phone: (765) 449-5576

Mail: technicalsupport@radianresearch.com

INSTRUCTION SHEET

PRNT-1600C PULSE RADIO TRANSMITTER

FCC ID: TIT-PRT-1600

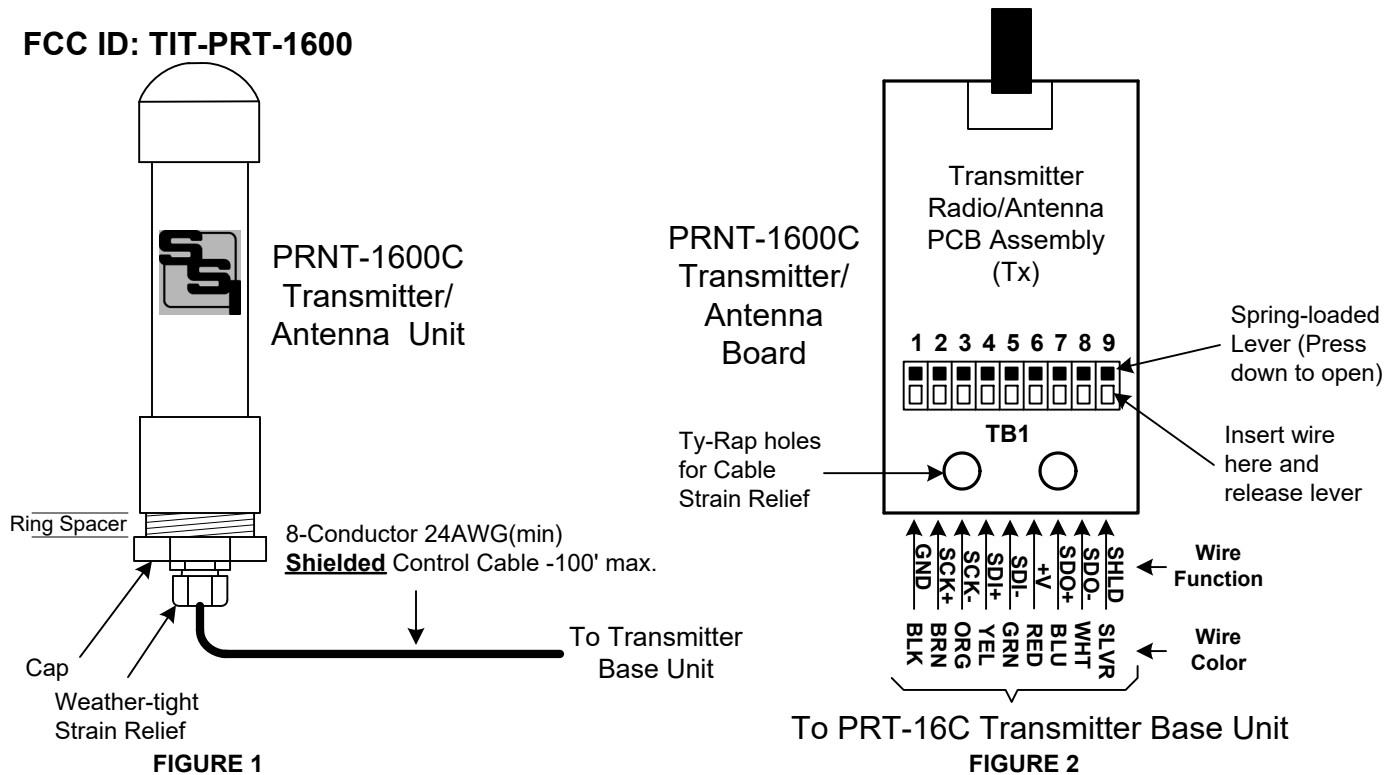

MOUNTING POSITION - (See Note Below on Cable Connection before mounting) The PRNT-1600C Transmitter/Antenna unit should be mounted in an upright position so that the cable is located on the bottom of the unit. Mount the unit as high as necessary to guarantee LINE-OF-SIGHT with the PRNR-1600C Receiver/Antenna unit. Mount using the aluminum mounting bracket supplied, making sure that the center of the transmitter is at least 6.1" away from any metal object such as a pole or metal building. Make sure that no metal mounting hardware is placed above the bottom of the PRNT-1600C Transmitter/Antenna unit case.

COLOR CODED BOARDS: Transmitter boards are GREEN.

CABLE CONNECTION TO PRNT-1600C - It is advisable that this task is performed, if possible, in a convenient, clean work area before mounting the Transmitter unit. Connect the 8-conductor 24AWG(min) **shielded** control cable to the 9-position connector on the PRNT-1600C Board. Access the PCB Assembly by unscrewing the Transmitter housing cap on the bottom of the unit. Remove the Transmitter assembly from the housing. Feed the control cable into the housing's weather-tight connector on the cap so that there is approximately 12" of cable through the cap. Tighten the weather-tight cable fitting so that the cable is not quite tight and easily slides back and forth. Alternately, non-metallic conduit ("Seal-Tight" or "Carflex") may be used to connect directly to the housing with 1/2" conduit connectors and run the control cable to the Base unit inside this conduit.

Strip approximately 2" of the control cable's outer jacket to expose the individual conductors, being careful not to cut the insulation of the conductors or any strands of the shield's drain wire. Strip the insulation of each conductor back 1/4". Connect each conductor of the cable to the 9-position connector TB1 using a small flat-blade screwdriver or other similar tool to open the spring-loaded connector as shown above in Figure 2. Press down on connector lever, slip wire into the hole and release. When all conductors are attached, attach a cable tie (ty-rap) through the Transmitter PCB Assembly's holes and tighten the control cable down, leaving about 1/4" of jacket above the ty-rap so as to provide adequate strain relief for the cable connections. Pull the cable back through the cap and weather-tight connector and place the Transmitter PCB Assembly back into the cap's slots. Tighten the weather-tight connector to secure the assembly in place. Put the ring spacer over the Cap's threads and insert the Transmitter Assembly into the housing. Tighten the cap until spacer is tight. For best results, keep the length between the Transmitter and the Base Unit to the minimum practical distance. When Transmitter installation is complete, secure cap to mounting bracket using sheet metal screw in slot.

INSTRUCTION SHEET

PRT-1600 PULSE RADIO TRANSMITTER

(con't)

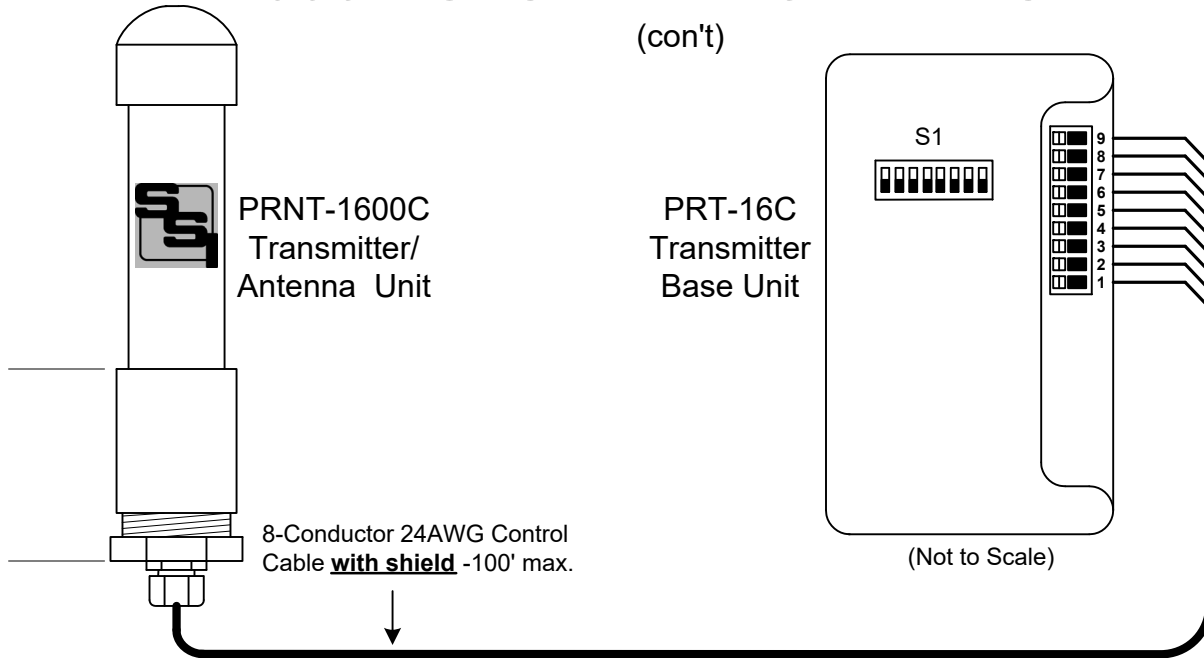

POWER INPUT - The PRNT-1600C receives its power supply from the PRT-16 Transmitter Base unit.

METER INPUTS - See the PRT-16C Base Unit Instruction Sheet (page 10) for detailed information on connecting the K-Y pulse inputs to the Electric Meter's KYZ Pulse output.

RADIO OUTPUT - The PRT-1600C's Transceiver/Antenna Unit (PRNT-1600C) contains a 900MHz band FHSS radio transceiver with an integral antenna mounted inside the unit. See diagram for mounting method and considerations. Transmission is LINE OF SIGHT up to approximately 5,000 feet max. Metal poles, buildings or other objects will affect the distance the radio system will effectively work. Trees may also affect transmission distance. The user bears all responsibility for proper mounting and operation of the unit within the PRT-1600's operating parameters.

TRANSMITTER CHANNEL - Set the channel number (hop sequence) using DIP Switches #1 through #3 ON DS1 as shown in Table 1 on page 4. This is set on the PRT-16C Transmitter Base Board.

NOTICE TO USER -

FCC ID: TIT-PRT-1600

This device complies with Part 15 of the FCC Rules. Operation is subject to the following two conditions:

1. This device may not cause harmful interference; and
2. This device must accept any interference received including interference that may cause undesired operation.

INSTRUCTION SHEET

PRNT-1600C RADIO/ANTENNA UNIT WIRING

FIGURE 3

Wire Connection Assignments

Terminal #	Function	Cond #	Color	Size (AWG)
1	GROUND	1	BLK	24
2	SCK+	2	BRN	24
3	SCK-	3	ORG	24
4	SDI+	4	YEL	24
5	SDI-	5	GRN	24
6	VIN	6	RED	24
7	SDO+	7	BLU	24
8	SDO-	8	WHT	24
9	SHIELD	-	SILVER	24

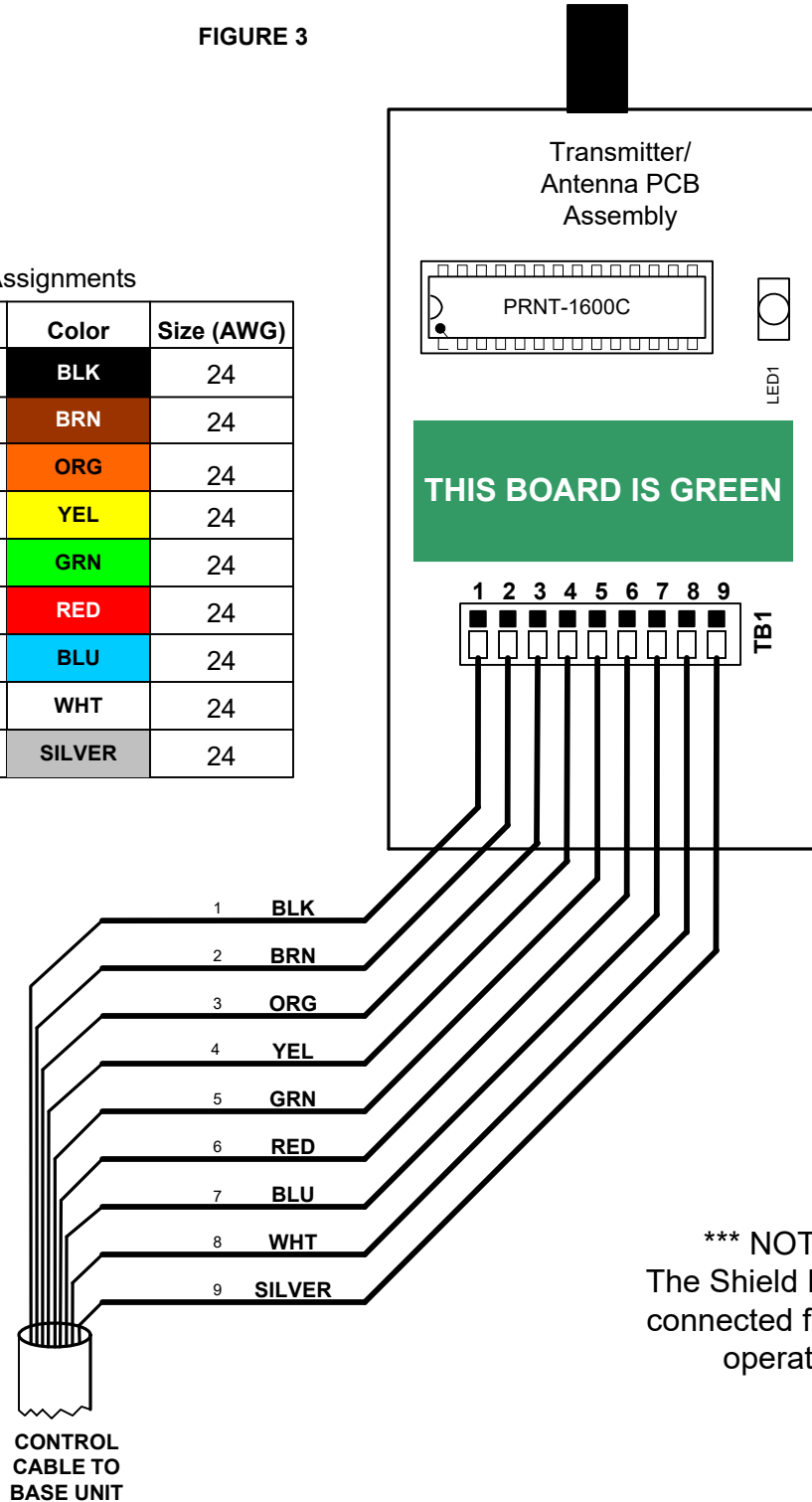

*** NOTE:***
The Shield MUST be
connected for proper
operation.

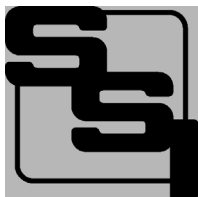

SOLID STATE INSTRUMENTS

by Radian Research, Inc
3852 Fortune Dr, Lafayette, IN 47905
Phone: (765) 449-5576

Mail: technicalsupport@radianresearch.com

INSTRUCTION SHEET

PRT-16C BASE UNIT

Setting the System CHANNEL - Each system -- the Transmitter and Receiver -- must operate on one of six different channels. A "channel" is a collection of 50 specific frequencies that are arranged in a specific "hop sequence". A unique channel allows multiple systems to operate in the same radio airspace without any interference with each other. Therefore, the transmitter and receiver must be set to the same channel setting. The channel address is set using a 3-bit binary code. See **Table 1** below right for the list of channels. Note that Channel #6 is the highest channel number and even though there are eight unique switch combinations, Channel 6 is the highest channel that can be selected. The last two switch combinations result in Channel #5 being selected.

Switch #4 - LED Timeouts - If enabled, **UP**, LED's 1-5 turn off after 10 minutes thus saving energy particularly in battery-powered applications. Any Dip Switch change, re-enables LEDs for 10 minutes. If **DOWN**, the LED Timeout is disabled and LEDs 1-5 indicate status all the time.

Switch #5 - Not used.

Switch #6 - Not used

Switch #7 - Setting the Transmitter Input Mode - The PRL-1600C can accept either Form C or Form A inputs. In the Form C (3-Wire) mode, each input channel uses the K, Y and Z inputs. Two independent 3-Wire meter pulse channels can be transmitted. In the Form A (2-Wire) mode, each pulse channel uses the K (common) and a Y input. Four independent 2-Wire meter pulse channels can be transmitted. Set **Switch #7** to the **DOWN** position for the Form A mode and **UP** for Form C mode.

Switch #8 - Pairing the Transmitter and Receiver - The PRT-1600 System requires that each Transmitter and Receiver are paired together. Each Transmitter must learn the address of the Receiver it is designated to talk to. This makes it possible for the Transmitter to only talk to the designated Receiver and ignore other devices sending and receiving information on a particular frequency. After installation is complete, perform the pairing procedure described on page 17 ONLY IF the system has not been previously paired at the factory. *****Do not switch #8 UP if the system is already paired.*****

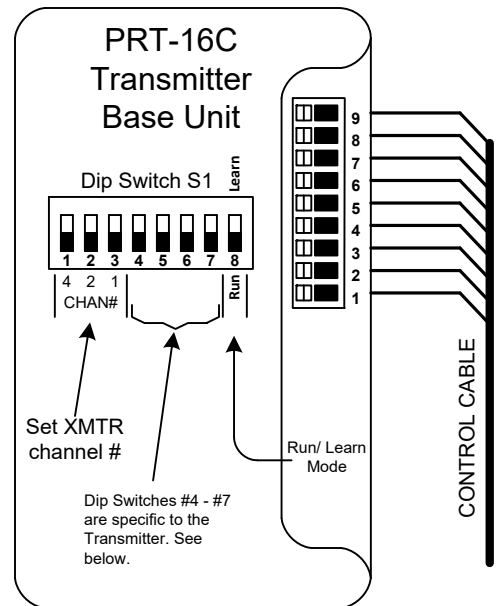

TABLE 1

CHANNEL#	SW#1	SW#2	SW#3
1	DN	DN	DN
2	DN	DN	UP
3	DN	UP	DN
4	DN	UP	UP
5	UP	DN	DN
6	UP	DN	UP
5	UP	UP	DN
5	UP	UP	UP

TABLE 2

LED Timeout	SW#4
Timeout Enable	UP
Timeout Disable	DN

TABLE 3

Input Mode	SW#7
FORM A (2W)	DN
FORM C (3W)	UP

TABLE 4

Run/Learn	SW#8
RUN	DN
LEARN	UP

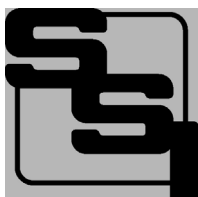

SOLID STATE INSTRUMENTS

by Radian Research, Inc

3852 Fortune Dr, Lafayette, IN 47905

Phone: (765) 449-5576

Mail: technicalsupport@radianresearch.com

INSTRUCTION SHEET

PRT-16C PULSE TRANSMITTER BASE

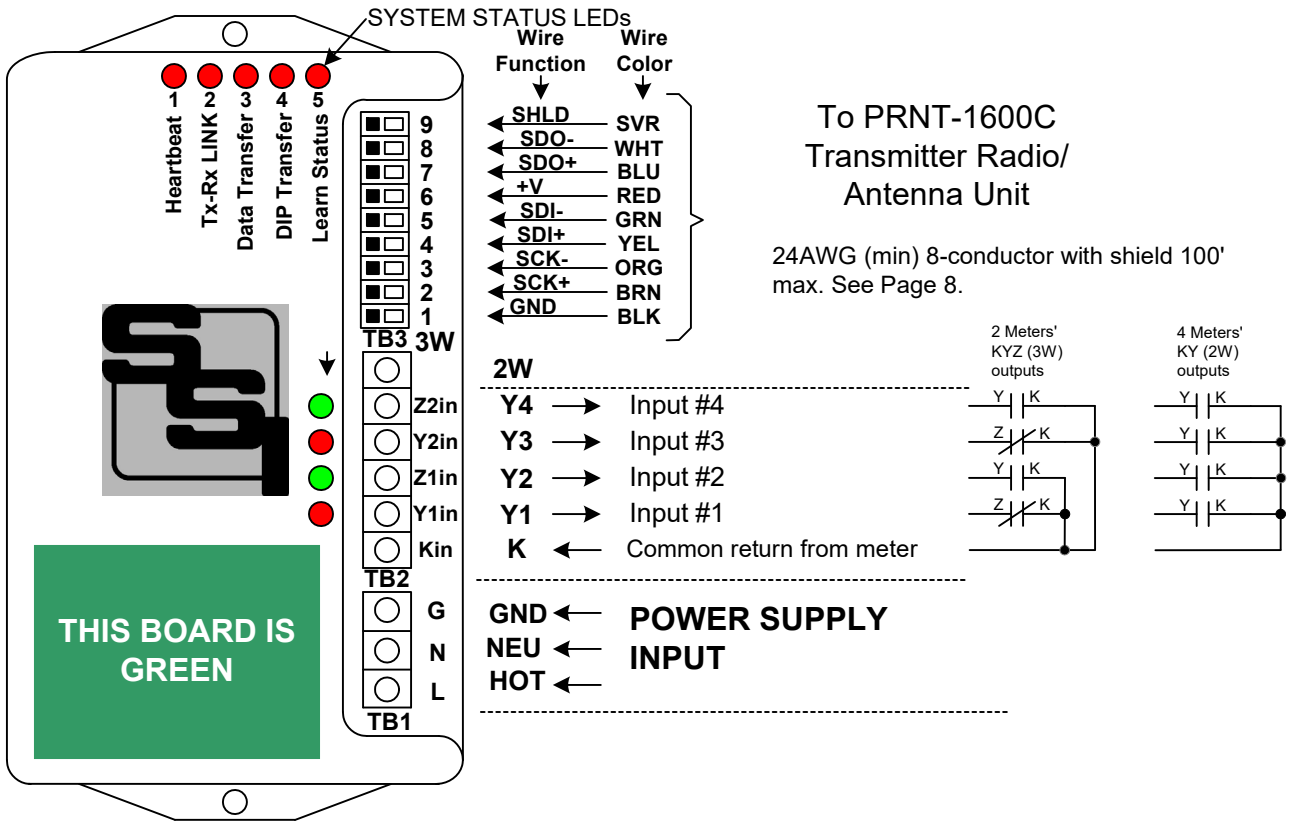

MOUNTING POSITION - The PRT-16C Base unit may be mounted in any position.

ENCLOSURE - The PRT-16C base unit is housed in a polycarbonate base and cover and is designed to be mounted into another electrical enclosure suitable for the application. Optional NEMA 3R or NEMA 4X outdoor enclosures are available.

POWER INPUT - For 120 to 277VAC, connect the "hot" lead to the **L1** power supply terminal. Connect the neutral lead to the **NEU** terminal. Connect the **GND** terminal to Ground.

INPUT CONFIGURATION - The PRT-16C accepts either 2 Form "C" (3-Wire) inputs using the K, Y & Z input terminals, or 4 Form "A" (2-Wire) inputs using the K & Y and K & Z terminals. See Dip Switch Definitions and Settings.

METER CONNECTIONS - Form A (2W) mode: Connect the PRT-16C's "K" and "Y1" input terminals to meter's "K" and "Y" terminals. The "Yx" input terminals are "pulled-up" to +13VDC power supply, making it compatible with open-collector transistor meter outputs, as well as all non-polarized mechanical or solid state pulse outputs. Form C (3W) mode: Connect the PRT-16C's "K", the "Y1" and the "Z1" input terminals to the meter's "K", "Y" and "Z" terminals. The PRT-16C's "K" terminal is the system common (return).

OUTPUT TO PRNT-1600C TRANSMITTER/ANTENNA UNIT - Connect the 8-conductor 24AWG(min) shielded control cable to the PRNT-1600C Transmitter/Antenna Unit. For best results, it is advisable to keep this length of this cable to the minimum practical distance.

STATUS LED's - These LED's indicate current system status. See Page 21.



SOLID STATE INSTRUMENTS

by Radian Research, Inc

3852 Fortune Dr, Lafayette, IN 47905

Phone: (765) 449-5576

Mail: technicalsupport@radianresearch.com

INSTRUCTION SHEET

PRR-1600CR -PULSE RADIO RECEIVER

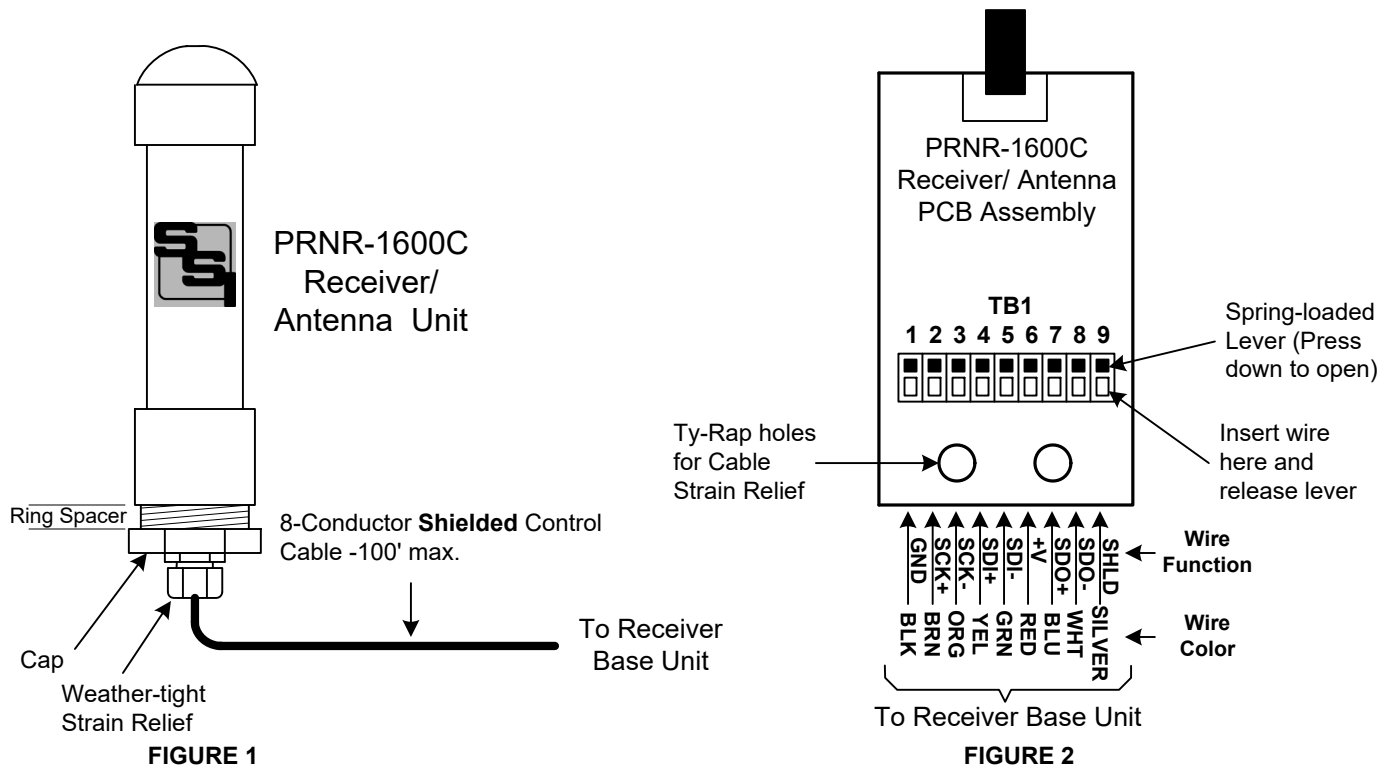

MOUNTING POSITION - (See Note Below on Cable Connection before mounting) The PRNR-1600C Receiver/Antenna unit should be mounted in an upright position so that the cable is located on the bottom of the unit. Mount the unit as high as necessary (14' min.) to guarantee LINE-OF-SIGHT with the PRNR-1600C Transmitter/Antenna unit. Mount using the aluminum mounting bracket supplied, making sure that the antenna of the receiver is at least 6.1" away from any metal object such as a pole or metal building. Make sure that no metal mounting hardware is placed above the bottom of the receiver unit case.

COLOR CODED BOARDS: Receiver boards are RED.

CABLE CONNECTION TO PRNR-1600C - Perform this task in a convenient, clean work area before mounting the Receiver unit. Connect the 8-conductor shielded control cable to the 9-position connector on the PRNR-1600C PCBA. (See page 15) Access the PCB Assembly by unscrewing the housing cap on the bottom of the unit. Remove the board assembly from the housing. Feed the control cable into the housing's weather-tight connector on the cap so that there is approximately 12" of cable through the cap. Tighten weather-tight cable fitting so that the cable is not quite tight and easily slides back and forth. Strip approximately 2" of the control cable's outer jacket to expose the individual conductors, being careful not to cut the insulation of the conductors or any strands of the shield's drain wire. Strip the insulation of each conductor back 1/4". Connect each conductor of the cable to the 9-position connector TB1 using a small flat-blade screwdriver or other similar tool to open the spring-loaded connector as shown above in Figure 2. Press down on the connector lever, slip wire into hole and release. When all conductors are attached, attach the cable tie (ty-rap) included through the PCBA's holes and tighten the control cable down, leaving about 1/4" of jacket above the ty-rap so as to provide adequate strain relief for the cable connections. Pull the cable back through the cap and weather-tight connector and place the PCB Assembly back into the cap's slots. Tighten the weather-tight connector (cable gland, if used) to secure the assembly in place. Rotate the board until it is perpendicular with the transmitter, making sure that the Antenna is 6.1" away from any metallic mounting surface. Put the ring spacer over the Cap's threads and tighten the cap until spacer is finger tight. For best results, keep the distance between the Receiver and the Base Unit to the minimum practical distance. When PCBA installation is complete, secure cap to mounting bracket using sheet metal screw in slot.

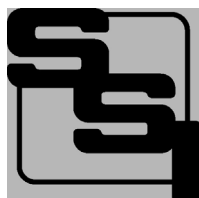

SOLID STATE INSTRUMENTS

by Radian Research, Inc

3852 Fortune Dr, Lafayette, IN 47905

Phone: (765) 449-5576

Mail: technicalsupport@radianresearch.com

INSTRUCTION SHEET

PRR-1600CR PULSE RADIO RECEIVER

(con't)

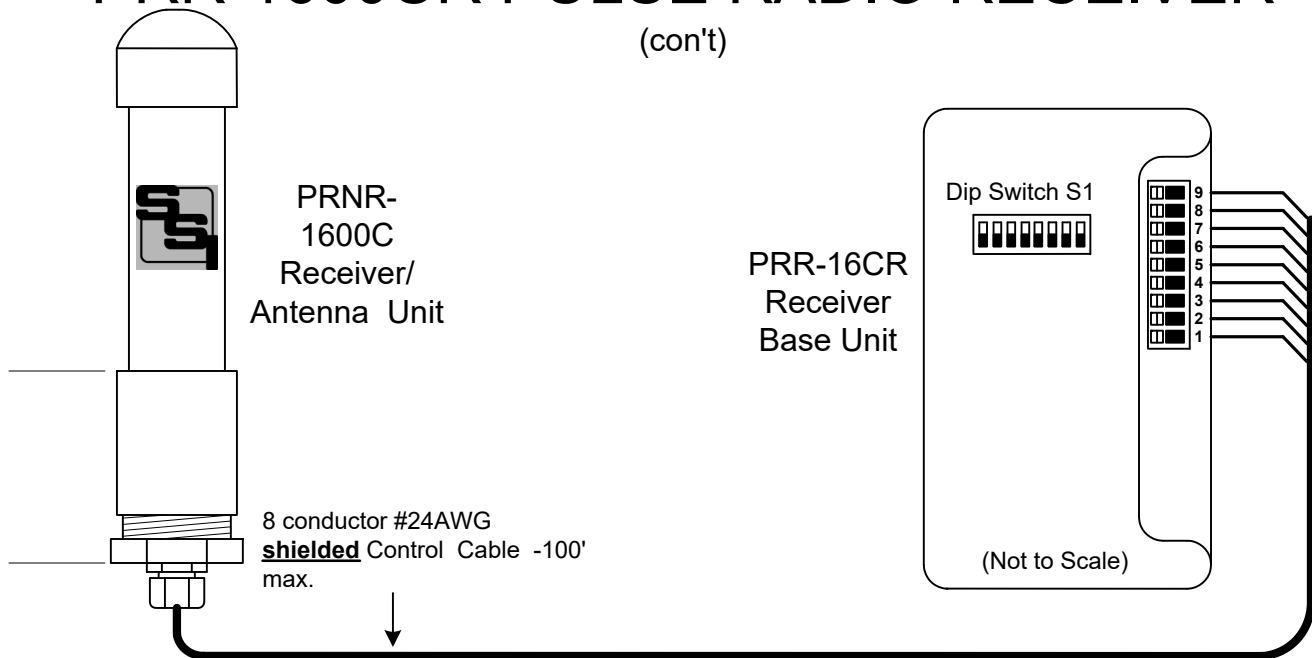

POWER INPUT - The PRNR-1600C receives its power supply from the PRR-16 Receiver Base unit.

PULSE OUTPUTS - See the PRR-16CR Base Unit Instruction Sheet for detailed information on connecting the KYZ Outputs to the receiving device. The receiving (destination) device may be the input to an energy management system, recorder, SCADA system, RTU, or other device configured to receive pulses.

RADIO RF INPUT - The PRNR-1600C's Receiver/Antenna Unit contains a low-power 900MHz radio transceiver with an integral antenna mounted inside the unit. Observe the following application guidelines: 1.) Mount the transceiver as directed on page 11; 2.) Locate the PRNR-1600C Receiver/Antenna unit so it is LINE-OF-SIGHT with the transmitter of the system; 3.) Ensure that all metal objects, trees and other obstructions, which may affect the distance the radio system will effectively work, are not within the line-of-sight between the transmitter and receiver.

NOTICE TO USER - This equipment has been tested and found to comply with the limits for a class B digital device, pursuant to part 15 of the FCC Rules. These limits are designed to provide reasonable protection against harmful interference in a residential installation. This equipment generates, uses and can radiate radio frequency energy and if not installed and used in accordance with the instructions, may cause harmful interference to radio communications. However, there is no guarantee that interference will not occur in a particular installation. If this equipment does cause harmful interference to radio or television reception, which can be determined by turning the equipment off and on, the user is encouraged to try to correct the interference by one or more of the following measures:

- * Reorient or relocate the receiving antenna.
- * Increase the separation between the equipment and receiver.
- * Connect the equipment into an outlet on a circuit different from that to which the receiver is connected.
- * Consult the dealer or an experienced radio/TV technician for help.

In order to maintain compliance with FCC regulations, shielded cables must be used with this equipment. Operation with non-approved equipment or unshielded cables is likely to result in interference to radio and TV reception. The user is cautioned that changes and modifications made to the equipment without the approval of manufacturer could void the user's authority to operate this equipment.

INSTRUCTION SHEET

PRR-16CR BASE UNIT

Setting the System CHANNEL - Each system -- the Transmitter and Receiver -- must operate on one of six different channels. A "channel" is a collection of 50 specific frequencies that are arranged in a specific "hop sequence". A unique channel allows multiple systems to operate in the same radio airspace without any interference with each other. Therefore, the transmitter and receiver must have the same channel setting. The channel address is set as a 3-bit binary code. See **Table 1** at right for complete list of the channels. Note that Channel #6 is the highest channel number and even though there are eight unique switch combinations, Channel 6 is the highest channel that can be selected. The last three switch combinations all result in Channel #6 being selected.

Switch #4 - Status LED Timeouts - If enabled, **UP**, LED's 1-5 turn off after 10 minutes thus saving energy particularly in battery-powered applications. Any Dip Switch change, re-enables LEDs for 10 minutes. If **DOWN** LEDs 1-5 indicate status all the time.

Switch #5 - Set Pulse Output Mode. Sets the output pulse to Toggle mode (**DOWN**) or 100mS (**UP**) when in Form A mode.

Switch #6 - Not used.

RSSI Indicator* - The receiver has a Signal Strength Indicator to show the signal strength of the Transmitter. **This is a test mode and can only be used during installation.** See Diagnostics on page 20. Once the system is operational, set **Switch #7 DOWN** to turn off the RSSI.

Pairing the Transmitter and Receiver - The PRL-1600C System requires that each Transmitter and Receiver are paired together. Each Transmitter must learn the address of the Receiver it is designated to talk to. This makes it possible for the Transmitter to only talk to the designated Receiver and ignore other devices sending and receiving information on a particular frequency. After installation is complete perform the **Pairing Procedure** described on page 17 **ONLY** if the pairing procedure has NOT been done at the factory. *****Do not put switch #8 into the UP position if the system has already been paired.*****

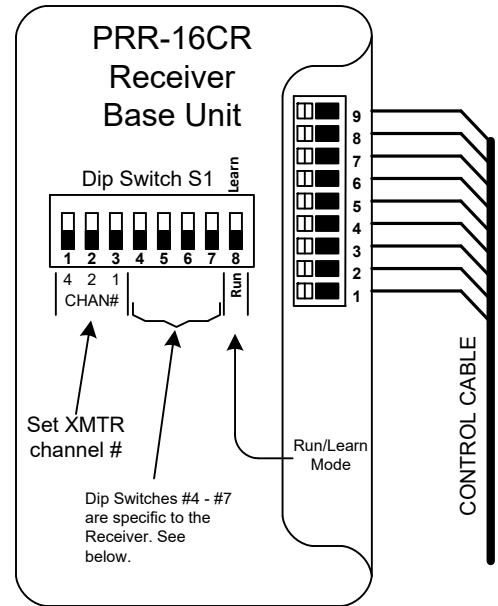

TABLE 1

CHANNEL#	SW#1	SW#2	SW#3
1	DN	DN	DN
2	DN	DN	UP
3	DN	UP	DN
4	DN	UP	UP
5	UP	DN	DN
6	UP	DN	UP
5	UP	UP	DN
5	UP	UP	UP

TABLE 2

LED Timeout	SW#4
Timeout Enable	UP
Timeout Disable	DN

TABLE 3

Pulse Width	SW#5
TOGGLE	DN
100 mS	UP

TABLE 4

RSSI Mode	SW#7*
RSSI Disable	DN
RSSI Enable	UP

TABLE 5

Run/Learn	SW#8
RUN	DN
LEARN	UP

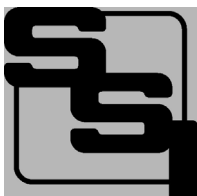

SOLID STATE INSTRUMENTS

by Radian Research, Inc

3852 Fortune Dr, Lafayette, IN 47905

Phone: (765) 449-5576

Mail: technicalsupport@radianresearch.com

INSTRUCTION SHEET

PRR-16CR PULSE RECEIVER BASE UNIT

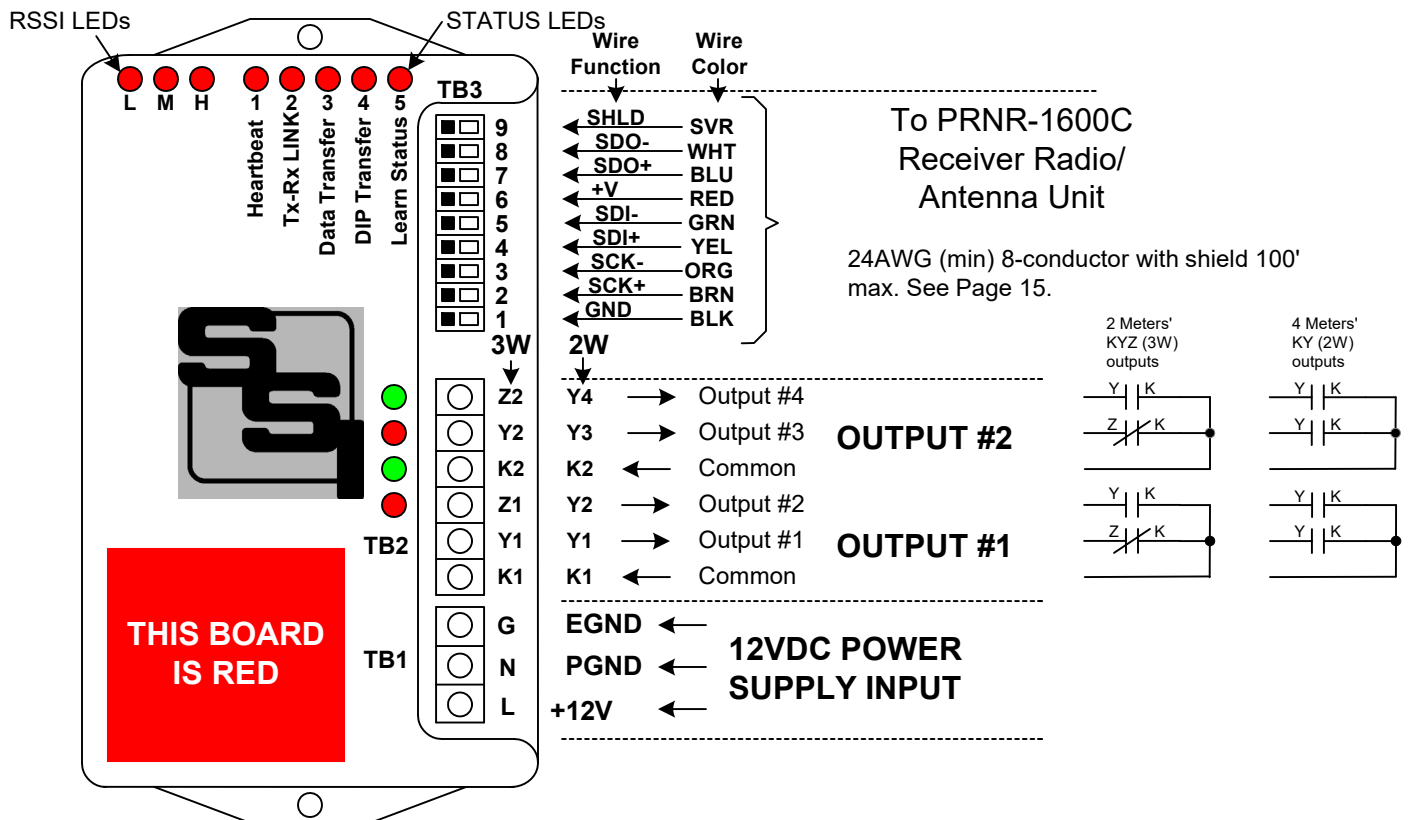

GENERAL - The PRR-16CR serves as a base unit, and termination point for the PRNR-1600C receiver radio/antenna unit. It contains a power supply, output relays and all connection points for the receiver/antenna unit.

ENCLOSURE - The PRR-16CR base unit is housed in polycarbonate base and cover and is designed to be mounted into another electrical enclosure suitable for the application. NEMA 3R and 4X raintight enclosures available.

POWER INPUT - For a supply of +12VDC, use the the **L (Line)** terminal on TB3 for the "+" lead. Connect the Negative power supply lead to the **N** terminal. Connect the **G** terminal to Ground. GROUND MUST BE CONNECTED TO A GOOD ELECTRICAL SYSTEM GROUND!!! If Power GND and Earth Ground are the same, connect both N and G terminals to GROUND. For +15 to +48VDC Power Supply inputs, the connections are the same: + to the "L" terminal and the - to the "N" terminal.

SIGNAL INPUT - The PRNR-1600C receiver/antenna unit connects to the 9-position connector labelled TB2. Terminals are numbered in the same order on the PRNR-1600C and the PRR-16. Connect #24AWG 8-conductor (8-conductor s) shielded control cable between the PRNR-1600C receiver/antenna board and the PRR-16 making sure that all connections are matched up on both ends: 1 to 1; 2 to 2; etc. Make sure that the control cable's shield is connected to position 9 on each end.

STATUS LEDs - The PRR-16CR has five status LEDs to indicate the status of the system at all times. See Page 22 for description of the Status LED functions.

RSSI SIGNAL STRENGTH INDICATOR - The PRR-16CR contains a 3-LED bar graph that tells the relative signal strength coming from the Transmitter. It consists of three RED LEDs in the upper left-hand corner of the board.

OUTPUT CONFIGURATION - The PRR-16CR contains four solid state Form A dry-contact outputs, two each for both "K", "Y" and "Z" outputs. Each solid state output is limited to 100mA@ 250VAC, 800mW maximum. Fuses are sized at 1/10th amp (100mA). Do not exceed this rating as the device will be destroyed. Transient voltage protection for the contacts of the solid state relays are provided by MOVs on board.

STATUS LED's - These LED's indicate current system status. See Page 22 & 23.

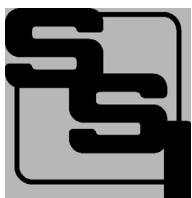

SOLID STATE INSTRUMENTS

by Radian Research, Inc

3852 Fortune Dr, Lafayette, IN 47905

Phone: (765) 449-5576

Mail: technicalsupport@radianresearch.com

INSTRUCTION SHEET

PRNR-1600C RADIO/ANTENNA UNIT WIRING

Wire Connection Assignments

Terminal #	Function	Cond #	Color	Size (AWG)
1	GROUND	1	BLK	24
2	SCK+	2	BRN	24
3	SCK-	3	ORG	24
4	SDI+	4	YEL	24
5	SDI-	5	GRN	24
6	VIN	6	RED	24
7	SDO+	7	BLU	24
8	SDO-	8	WHT	24
9	SHIELD	-	SILVER	24

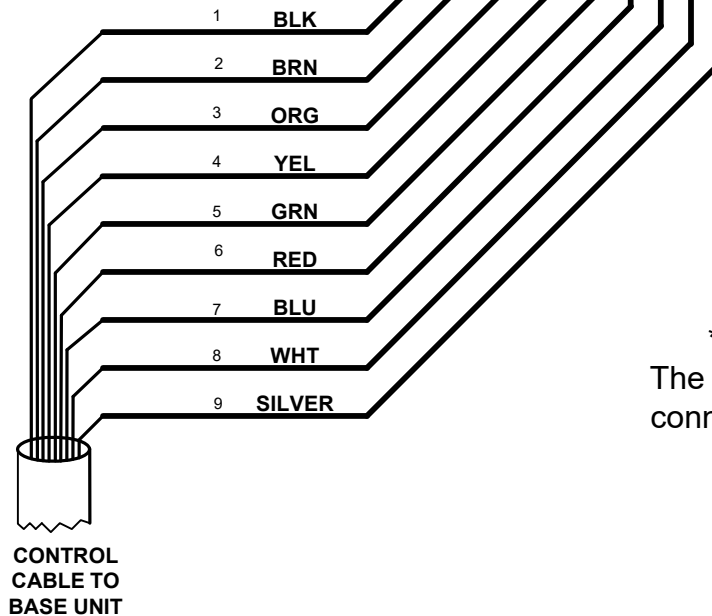
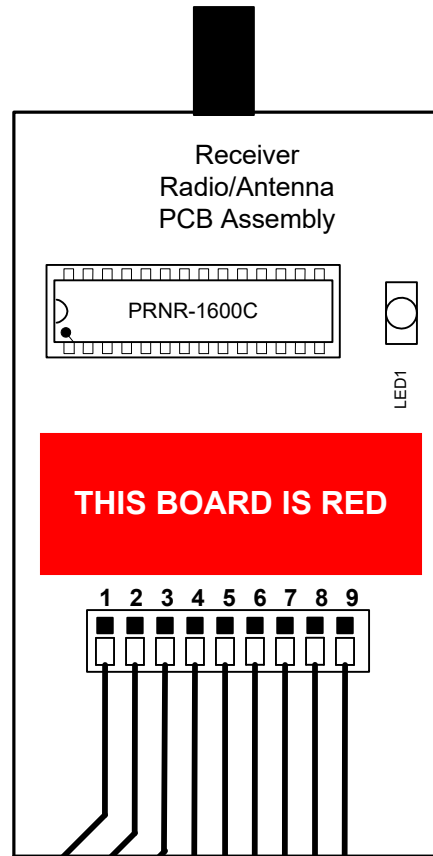

*** NOTE:***
The Shield **MUST** be
connected for proper
operation.

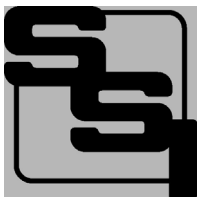

SOLID STATE INSTRUMENTS

by Radian Research, Inc
3852 Fortune Dr, Lafayette, IN 47905
Phone: (765) 449-5576
Mail: technicalsupport@radianresearch.com

INSTRUCTION SHEET

PRR-16CR PULSE RECEIVER BASE UNIT

(CON'T)

USING THE OUTPUT IN 3-WIRE MODE - When the PRL-1600C is operated in the Form C (3-Wire) mode, each output channel "toggles" back and forth like a single-pole, double throw switch. For one pulse there is continuity between K and Y (a closure) while there is no continuity between K and Z (an open). Upon the next pulse being received from the meter they reverse positions, K-Z closes and K-Y opens. In Form C mode, Y and Z are always opposite of each other. When one is closed and the other is open. There is logic in the PRNR-1600C's software that disallows two pulses of the same type in a row in Form C mode. They **MUST** alternate.

Each KYZ output is isolated, meaning there is no voltage applied to it internally. The wetting voltage for each KYZ output of the PRR-16C output must be supplied by the receiving ("downstream") device or by an auxiliary power supply. The outputs are solid state and are non-polarized. They may be used for AC or DC voltages. The output is limited to 100mA@ 250VAC, 800mW maximum. Fuses are sized at 1/10th amp (100mA). Do not exceed this rating as the solid state MOS-FET switching device may be destroyed. Transient voltage protection for the contacts of the solid state relays are provided by MOVs on board between the K and Y, as well as the K and Z outputs. Depending on user requirements the PRL-1600C can be operated in Form C mode and only two wires used on the output for the downstream device. This is perfectly acceptable, but remember to double the Form C pulse constant if your receiving device does not automatically adjust the pulse value.

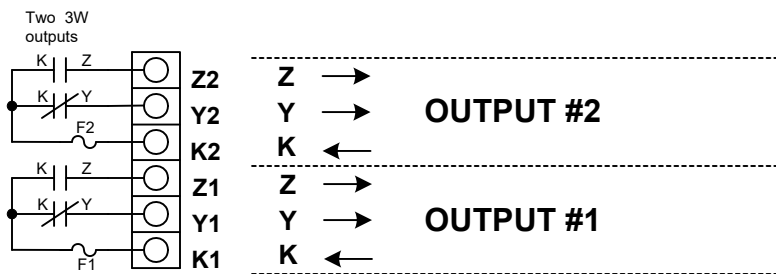

USING THE OUTPUT IN 2-WIRE MODE -

The PRR-16C's two KYZ outputs contain four solid state Form A dry-contacts and may be used independently as four Form A outputs. In this case instead of Y and Z being opposite of each other they are independently used. See the numbering of the output terminals in the diagram below. Even though the devices are operated independently in Form A mode, each set (Y1-Y2 and Y3-Y4) must be operated at the same voltage, from the same voltage source.

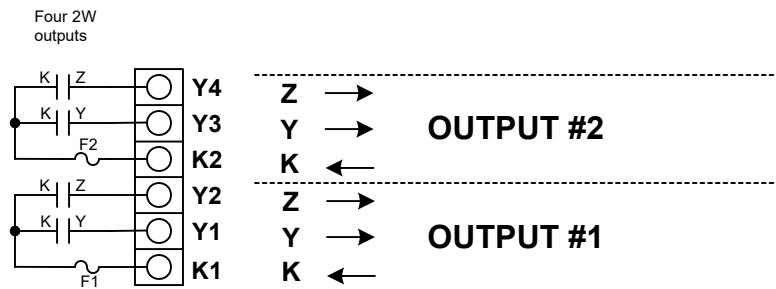

SOLID STATE INSTRUMENTS

by Radian Research, Inc
3852 Fortune Dr, Lafayette, IN 47905
Phone: (765) 449-5576

Mail: technicalsupport@radianresearch.com

Transmitter and Receiver Pairing Procedure (Learn Mode)

***** THE PRL-1600C IS FACTORY PAIRED.
DO NOT PAIR THE SYSTEM UPON
INITIAL INSTALLATION. *****

Required only if pairing has not been done or if one end has been replaced.

This procedure pairs the PRT-1600C Transmitter with a specific PRR-1600C Receiver. The PRL-1600C system WILL NOT work unless this procedure is completed. The PRL-1600C system is factory paired and tested as a system, so the pairing procedure is not normally necessary to do at installation. In the event that Dip Switch #8 is put in the UP position either accidentally or intentionally when the system is powered, the unit may be unpaired. Therefore, this procedure will need to be performed.

1. With the system powered down (OFF) at both ends, set the transmitter and receiver channel numbers (Dip Switches 1-3) to the same setting. (See instructions on pages 9 and 13 for the transmitter and receiver, respectively).
2. Set Dip Switch #8 on both the transmitter and receiver to the "UP" position to put the system in the Learn mode.
3. Turn on power to the PRR-1600C Receiver. The RED system status LED #5 should flash slowly about 1 flash per second. Ignore LED's 1-4.
4. Turn on power to the PRT-1600C Transmitter. The RED system status LED #5 should flash in slow mode, about once per second) for a few seconds. Ignore LED's 1-4.
5. Within 4 to 5 seconds, LED #5 on both boards should flash fast, about 4 times per second. The fast flash means that the system has paired itself together.
6. Return Dip Switch #8 to the "DOWN" position on PRR-16 Receiver Base FIRST. This puts the Receiver in the RUN (normal operation) mode. Status LED#5 will not normally light in the RUN mode.
7. Return Dip Switch #8 to the "DOWN" position on the PRT-16 Transmitter Base SECOND. This puts the Transmitter into the RUN (normal operation) mode. Status LED#5 will not normally light in the RUN mode.
8. Once both units are in the RUN mode, observe the System Status LEDs. They should be operating as indicated in Appendix C. KYZ outputs on the Receiver should begin changing state to reflect the state of the transmitter's input after 10-20 seconds. The pulse output LED's on the Receiver will be delayed by 10 seconds from the pulses that occur on the Transmitter's pulse inputs.
9. If the Transmitter and Receiver boards ever need to be changed or if the transmitter and receiver units ever have to be deployed in a new system with a different transmitter or receiver board, the pairing procedure will have to be performed again.

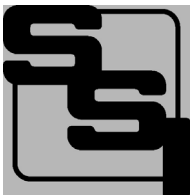

SOLID STATE INSTRUMENTS

by Radian Research, Inc

3852 Fortune Dr, Lafayette, IN 47905

Phone: (765) 449-5576

Mail: technicalsupport@radianresearch.com

PRL-1600CR Wireless Pulse Link Application

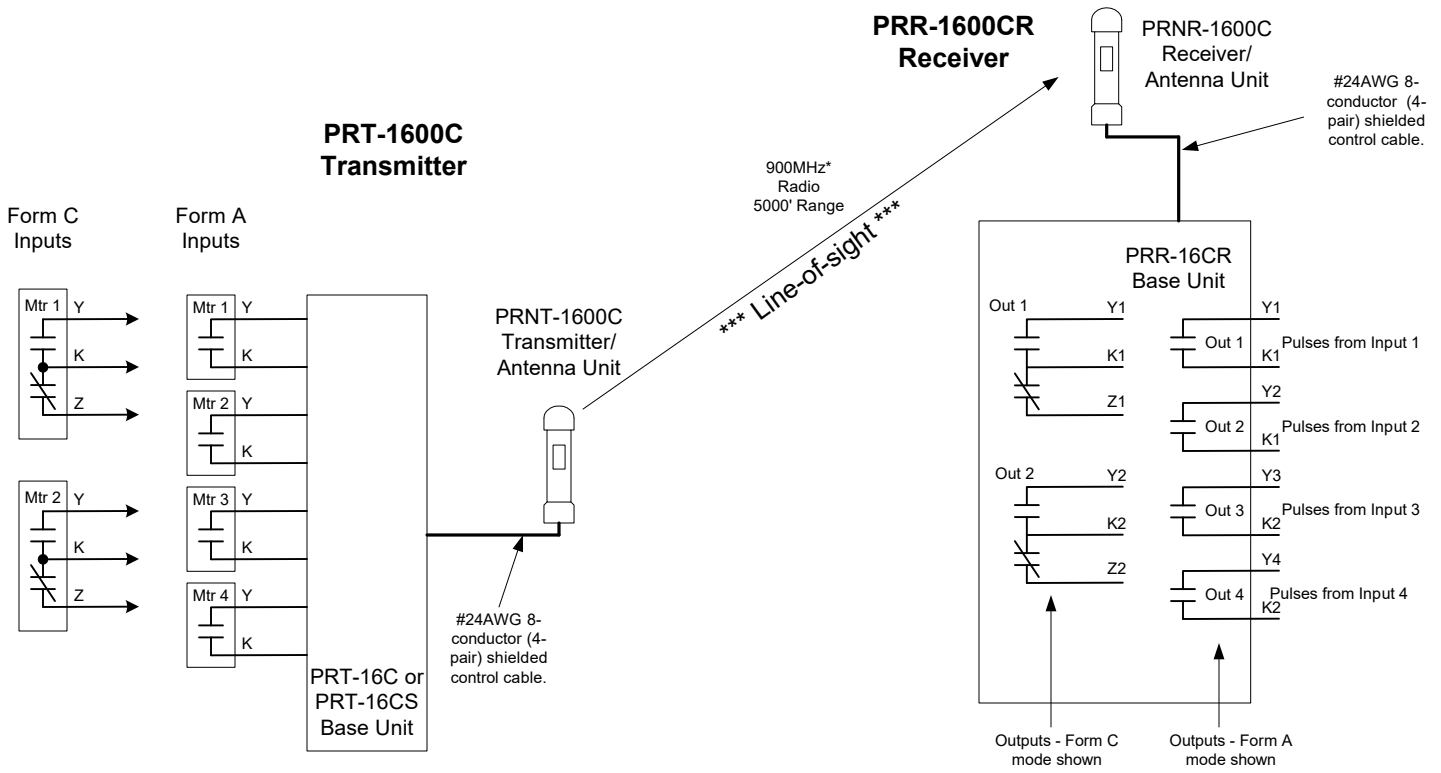

Notes:

- 1.) Configure each end to the same mode Form A or Form C. Make sure that the utility configures all the meter's outputs for toggle mode, not momentary mode. Form C (3-wire) mode is preferred from the meter to the transmitter's input. Set both the transmitter and receiver to Form C by setting Dip Switch #6 to the UP position. Using two wires (K and Y) on a Form C output is acceptable.
- 2.) Dip Switch #8 must be DOWN on the both ends for normal operation (in RUN mode).
- 3.) Transmission is Line-Of-Sight and must not be blocked by trees, buildings, metal poles, trucks, railcars, etc.
- 4.) Transmission distance is variable up to 5000' depending on topography and conditions. Distance and reliability will increase as the height mounted above the ground increases. During extremely heavy rain, transmissions may not be reliable.

PRL-1600CR Wireless Pulse Link System Diagram		REVISIONS	
		NO.	DATE
DATE ORIGINAL	SCALE		
01/01/2025	N/A		
LATEST REVISION	JOB NO.	CHECKED	DRAWN
A			WHB

**Solid State Instruments
by Radian Research Inc**
 3852 Fortune Dr
 Lafayette, IN 47905
 (765) 449-5576
 technicalsupport@radianresearch.com
 www.solidstateinstruments.com

Troubleshooting and Tech Support

- 1.) Use **shielded** 8-conductor control cable between the PRT-16C Transmitter Base Unit and the PRNT-1600C Transmitter/Antenna unit, as well as between the PRR-16C Receiver Base Unit and the PRNR-1600C Receiver/Antenna unit. Solid State Instruments' part number 0715-1005 is a the standard indoor-rated 8-conductor #24AWG shielded control cable sold by the foot. This cable is not UV-rated so must be enclosed in seal-tight, liquid-tight or other non-metallic conduit. Part number 0715-1018 is the UV-Stabilized outdoor-rated version. You can acquire your own **SHIELDED** 8-conductor cable but insure a high-quality communications cable with four #24 stranded conductor pairs. Do not use solid conductor wire, especially thermostat wire. Do not use any heavier wire than #22 AWG since there is limited space and it will be difficult to work with.
- 2.) Make sure that the transmission path between the Transmitter and the Receiver is free of ANY obstacles or anything that can interrupt the radio transmission line-of-sight path between the transmitter and receiver. The Transmitter or Receiver Radio/Antenna units **MUST** be in continuous sight of each other – no interruptions from cars, trucks, railcars, trees, light poles, metal buildings, ANYTHING!
- 3.) Mount the Transmitter or Receiver Radio/Antenna units as high up off the ground as reasonably possible to prevent RF reflections from the ground. This will increase range and reliability, and also allow for certain obstacles to be avoided. Do not mount the Transmitter Radio/Antenna unit next to high voltage powerlines.
- 4.) Program the pulse constant (Ke value) of the electric meter high enough to allow for a pulse rate that will not exceed 2 pulses per second at maximum KW demand. This is well below the system's maximum pulse throughput rate but ensures excellent reliability. NOTE: the PRL-1600C system does not change or modify the pulse values in any way. The pulse value is completely determined by the Ke value of the meter and the metering installation multiplier, which is based on Current Transformer (CT) and Potential Transformer (PT) ratios. Some meters are different, and the programming of the pulse constant may vary from meter brand to meter brand.
- 5.) In extremely heavy rain or snow, the system may not be able to accurately receive all pulses transmitted. Like any other RF system, with enough interference, communications can be lost.
- 6.) RED System Status LEDs - The PRT-16C and PRR-16C Base Unit boards have System Status LEDs to help the installer determine whether the system is operating correctly. Please see the tables on Pages 21-23.
- 7.) If there is interference on the "hop sequence" channel you have selected, change to another channel. There are six channels to choose from. Both ends must have the same channel number. The system does not need to be powered down to change the channel #. However, it will not communicate while the channel numbers are not identical.

8. The system's maximum reliable transmission distance will change with each installation since it is dependent on all of the environmental and electrical factors of each particular installation. While the distance is nominally specified as up to 5,000 feet, it may not work at the full range in some installations.

9. The Transmitter base unit is designed for mounting inside another control cabinet or enclosure appropriate and suitable for the particular application. If a NEMA 4X enclosure is required, order SSI P/N: 05000-47001A for the NEMA 4X Fiberglass 12" x 10" x 4" enclosure option. This option includes an interior mounting plate that the PRT-16C or PRR-16C mounts onto.

Troubleshooting Procedure:

- Check all wiring connections especially the control cable connections between each Radio/Antenna unit and its respective Base unit.
- Check that power is on and applied properly to all components.
- Check the RED and GREEN LEDs on the Transmitter and Receiver/Antenna boards and make sure they are flashing with one burst sequence every 10 seconds.
- Check to make sure that the Transmitter and Receiver units are both on the same channel (Dip Switches #1-3)
- Make sure that there is not another system operating in the same RF airspace that has the same channel hop sequence selected.
- Make sure that the Transmitter is set for the correct Input Mode, either Form A (2-wire) or Form C (3-wire). (Dip Switch #7)
- Check Red and Green LED's on each Base Unit's input or output, and make sure they are flashing with pulses received from the meter.
- Check the Status LEDs on the Transmitter and Receiver base units to insure proper operation of the system. (See Page 21 and 22 for LED definitions.)
- Use the Signal Strength LEDs (RSSI) on the Receiver to measure signal strength. Put Dip Switch #7 in the UP position on the Receiver to enable the RSSI indicator. Put in DOWN position when test complete to turn off RSSI. **Do not leave the RSSI indicator on during normal operation. Pulses will be lost if the RSSI is left on. The RSSI is a diagnostic tool only and not for normal operation.**
- Check that the antennas are securely screwed to the Radio/Antenna board.
- Use an ohmmeter or continuity checker across the KY terminals of each output and determine whether each is opening and closing by watching the output's resistance change. When the output is open, there should be infinite resistance. When the output is closed, the on-state resistance should be approximately 18 to 25 ohms.
- Is the "downstream" equipment, that is receiving the pulses from the Receiver, providing a wetting voltage to the dry-contact output of the Receiver? Is the wetting voltage within the maximum specifications?

Appendix A - PRT-1600C Dip Switch Settings and LED Indicators

PRT-16C Transmitter Base DIP Switch Settings											V4.01	
Hop Sequence			LED1-LED5 Timeout (10 minutes)	# of SPI Transmissions		Not Used		Input Mode		Learn Mode		
DIP1	DIP2	DIP3	DIP4		DIP5		DIP6		DIP7		DIP8	
{ 000 - Channel 1 001 - Channel 2 010 - Channel 3 011 - Channel 4 100 - Channel 5 101 - Channel 6 110 - Channel 5 111 - Channel 5 }			UP	Enabled	UP	6	UP	XXX	UP	Form C	UP	LEARN
			DOWN	Disabled	DOWN	4	DOWN	XXX	DOWN	Form A	DOWN	DOWN
Note1: Down (0), Up (1) -- Default All Down. Note2: Learn Mode supercedes all modes of operation.												

PRNT-1600C Transmitter Radio/Antenna LED Indicators			V4.01
	LED1 (D4 GREEN) Data Transfer	LED2 (D3 RED) RF Module Communication	
On Power Up			
Interval	-----	None	
10 Quick Blinks	-----	Unable to communicate with RF Module	
Run Mode			
Interval	10 Seconds	-----	
Burst/Blinks	Data Transmit/Receive	-----	
1 Blink		Every 10 sec Data Transferred	
3 Blinks		Every 10 s - Packet Received/CRC16 Error	
Learn Mode			
Burst/Blinks	Data Transmit/Receive		
Slow Blink		Learning	
Fast Blink		Done Learning	

PRT-16C Transmitter Base LED Indicators						V4.01
	LED1 Heartbeat	LED2 (PAIRED) Connection Status	LED3 (XMT)	LED4 (DIP XFER) DIP Settings Transfer/Ack	LED5 (LEARN)	
Run Mode						
Interval	3 Seconds	35 Seconds	10 Seconds	1 Second		
1 Blink	-----		Data Transfer	DIP Transfer	-----	
2 Blinks	-----		Data Transfer & Ack	DIP Transfer & Ack	-----	
3 Blinks						
On		Connected				
Off		No Connection				
Learn Mode						
Interval	3 Seconds		10 Seconds	1 Second		
1 Blink			Data Transfer	DIP Transfer		
2 Blinks			Data Transfer & Ack	DIP Transfer & Ack		
Slow Blink	-----	-----	-----	-----	Learning	
Fast Blink	-----	-----	-----	-----	Done Learning	

Appendix B - PRR-1600C Dip Switch Settings and LED Indicators

PRR-16C Receiver Base DIP Switch Settings											V4.01	
Hop Sequence			LED1-LED5 Timeout (10 minutes)	Fixed Pulse Width	Not Used		RSSI Enable		Learn Mode			
DIP1	DIP2	DIP3	DIP4		DIP5		DIP6		DIP7		DIP8	
{ 000 - Channel 1 001 - Channel 2 010 - Channel 3 011 - Channel 4 100 - Channel 5 101 - Channel 6 110 - Channel 5 111 - Channel 5 }			UP	Enabled	UP	100mS	UP	XXX	UP	Enabled	UP	LEARN
			DOWN	Disabled	DOWN	Toggle	DOWN	XXX	DOWN	Disabled	DOWN	RUN
Note1: Down (0), Up (1) -- Default All Down. Note2: Learn Mode supercedes all modes of operation.												

PRR-1600C Receiver Radio/Antenna LED Indicators			V4.01
	LED1 (D4 GREEN) Data Transfer	LED2 (D3 RED) RF Module Communication	
On Power Up			
Interval	-----	None	
10 Quick Blinks	-----	Unable to communicate with RF Module	
Run Mode			
Interval	10 Seconds	None	
Burst/Blinks	Data Transmit/Receive		
1 Blink		Every 10 sec Data Transferred	
3 Blinks		Every 10 s - Packet Received/CRC16 Error	
Learn Mode			
Burst/Blinks	Data Transmit/Receive		
Slow Blink		Learning	
Fast Blink		Done Learning	

PRR-16C Receiver Base LED Indicators						V4.01
	LED1 Heartbeat	LED2 (PAIRED) Connection Status	LED3 (RCV)	LED4 (DIP XFER) DIP Settings Transfer/Ack	LED5 (LEARN)	
Run Mode						
Interval	3 Seconds	35 Seconds	10 Seconds	1 Second		
1 Blink	-----		Data Transfer	DIP Transfer	-----	
2 Blinks	-----		Data Transfer & Ack	DIP Transfer & Ack	-----	
3 Blinks						
On		Connected				
Off		No Connection				
Learn Mode						
Interval	3 Seconds		10 Seconds	1 Second		
1 Blink			Data Transfer	DIP Transfer		
2 Blinks			Data Transfer & Ack	DIP Transfer & Ack		
Slow Blink	-----	-----	-----	-----	Learning	
Fast Blink	-----	-----	-----	-----	Done Learning	

APPENDIX C

STATUS LED DEFINITIONS

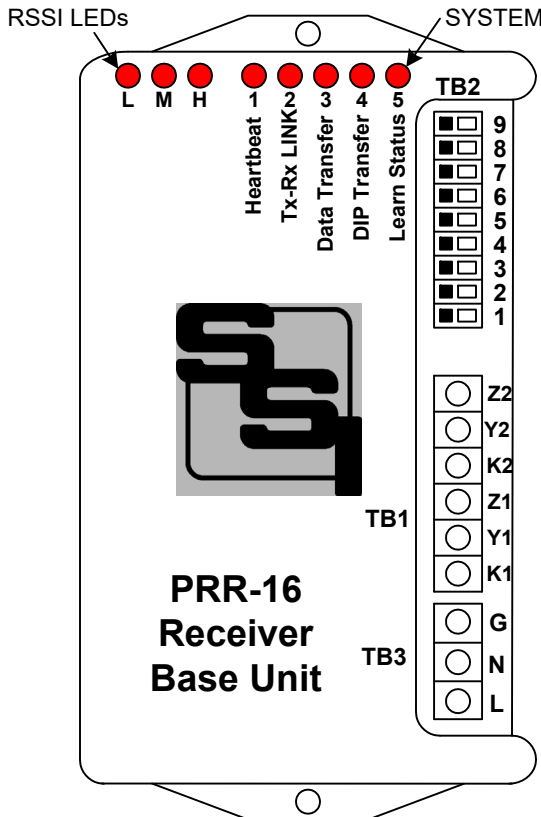

RSSI INDICATOR LEDES

GENERAL - The RSSI is the Receiver Signal Strength Indicator bar graph which shows the relative signal strength of the PRT-1600C's RF Signal. This is helpful in troubleshooting non-connectivity problems between the transmitter and receiver.

PROCEDURE - Switch DIP Switch #7 UP on the PRR-16C Receiver Base unit. You should see one or more of the three RSSI LED's turn on.

MEANING - The three LEDs on the PRR-16C(only) are labeled L, M and H for Low, Medium and High. If you have a strong or "High" signal, all three LEDs will turn on. If you have a Medium strength signal, you will see the M and L LEDs turn on. If you have a Low signal then you have a signal of low strength but it may be sufficient for the PRL-1600C to operate. If you have NO LED's on, then the PRL-1600C system will not operate. Please note that DIP Switch #4 must be down to be able to disable the LED Timeout function.

SYSTEM STATUS LEDES

GENERAL - The PRT-16C and PRR-16C have five System Status LEDs to indicate the status of the system at all times. These LEDs allow the installer and user to tell if the system is paired and operating correctly. More Detail in Appendices A and B, pages 21 and 22.

HEARTBEAT - LED #1 - LED#1 is the "heartbeat LED and blinks once every 3 seconds to tell the user/installer that the processor on the PRT/PRR-16 base units that the processor is running. If LED #1 is not blinking, the processor is not running or the board has no power being applied to it. Check wiring and power.

TX/RX LINK "PAIRED" - LED #2 - LED #2 on the PRR-16C Receiver Base Unit shows that the receiver has received a transmission from the transmitter in the last 35 seconds. LED #2 on the PRT-16C shows that the transmitter has received an acknowledgement back from the receiver in the last 35 seconds, and processed the information. If this LED is not lit, it is an indication that power is off at the opposite end, that the transmitter and receiver are not paired, or that some other condition exists that is causing the transmitter and receiver not to communicate or communicate reliably every 35 seconds. This could be caused by a Non-Line-of-Sight path.

DATA TRANSFER - LED #3 - LED #3 is the Data Transfer LED that shows that the data has been passed from each base unit to its respective Radio/Antenna unit. This should blink twice every 10 seconds. The first blink means that the base unit has sent the data and the second blink which should immediately follow the first blink means that the radio/antenna unit's processor has received the data packet and acknowledges it has received and processed it.

DIP TRANSFER - LED #4 - LED #4 is the Dip Transfer LED which shows that the dip switch status has been transferred from the base unit to the Radio Antenna unit. This LED blinks once a second to update the Radio/Antenna unit of the base unit's DIP switch settings.

LEARN STATUS - LED #5 - LED #5 shows the details of the Learn mode. This LED will not normally be lit during RUN operations. When the system is in the LEARN Mode, this LED will be on and show the state of the learning process. Please refer to the Pairing process sheet for a description of this LED's blinking pattern. If the LED lights during normal RUN operations, that indicates an overrange error, that too many pulses have been received to output them in 10 seconds.

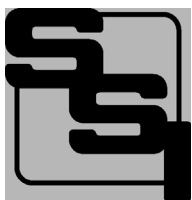

SOLID STATE INSTRUMENTS

by Radian Research, Inc

3852 Fortune Dr, Lafayette, IN 47905

Phone: (765) 449-5576

Mail: technicalsupport@radianresearch.com

APPENDIX D

STATUS LED DEFINITIONS

PRNT/PRNR RADIO/ANTENNA UNIT STATUS LEDS

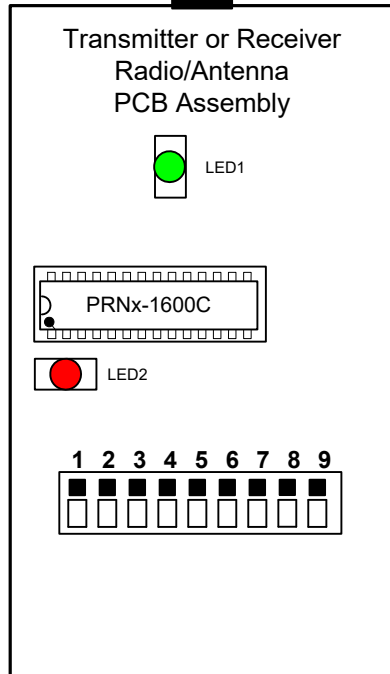

GENERAL - The PRNT-1600C Transmitter and PRNR-1600C Receiver Radio/Antenna boards have two LEDs which indicate the status of the Transmission and Reception of the pulse data. These LEDs will conclusively tell the installer if the system is paired and operating correctly.

LED #1 GREEN - The Green LED in normal operation will flash approximately 6 times in rapid succession once every 10 seconds. On the PRNT-1600C Transmitter Radio/Antenna board this means that the data packet is being transmitted. On the PRNR-1600C Receiver Radio/Antenna board this means that the data packet is being received from the Transmitter.

LED #2 RED - The Red LED in normal operation will flash once every 10 seconds. On the PRNT-1600C Transmitter Radio/Antenna board this means that the data packet was transmitted. On the PRNR-1600C Receiver Radio/Antenna board this means that the data packet was received and was processed by the microcontroller.

POWER UP - LED #2 RED - On Power Up, if LED #2 blinks 10 quick blinks, this is an indication that the microcontroller was unable to communicate with the RF Module. Reset RF module and microcontroller by cycling power to the entire transmitter or receiver side. If the 10 quick blinks persists, contact factory.

LEARN Mode - During the LEARN mode, LED #2 RED should blink slow, about 1 blink per second, while it is learning. When it is done learning, it will blink about 4 times per second.

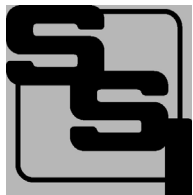

SOLID STATE INSTRUMENTS

by Radian Research, Inc

3852 Fortune Dr, Lafayette, IN 47905

Phone: (765) 449-5576

Mail: technicalsupport@radianresearch.com

FCC / IC NOTICES

This product contains FCC ID: OJM-HUMA-900 / IC: 5840A-HUMA900

This device complies with Part 15 of the FCC rules and Industry Canada license-exempt RSS standards. Operation of this device is subject to the following two conditions:

1. This device may not cause harmful interference, and
2. this device must accept any interference received, including interference that may cause undesired operation.

This equipment has been tested and found to comply with the limits for a Class B digital device, pursuant to Part 15 of the FCC Rules. These limits are designed to provide reasonable protection against harmful interference in a residential installation. This equipment generates, uses and can radiate radio frequency energy and, if not installed and used in accordance with the instructions, may cause harmful interference to radio communications. However, there is no guarantee that interference will not occur in a particular installation. If this equipment does cause harmful interference to radio or television reception, which can be determined by turning the equipment off and on, the user is encouraged to try to correct the interference by one or more of the following measures:

- Reorient or relocate the receiving antenna.
- Increase the separation between the equipment and receiver.
- Connect the equipment into an outlet on a circuit different from that to which the receiver is connected.
- Consult the dealer or an experienced radio/TV technician for help.

Any modifications could void the user's authority to operate the equipment.

Le présent appareil est conforme aux CNR d'Industrie Canada applicables aux appareils radio exempts de licence. L'exploitation est autorisée aux deux conditions suivantes:

1. l'appareil ne doit pas produire de brouillage, et
2. l'utilisateur de l'appareil doit accepter tout brouillage radioélectrique subi, même si le brouillage est susceptible d'en compromettre le fonctionnement.