

RPR-3PS

Elite Solid State

PULSE ISOLATION RELAY INSTRUCTION SHEET

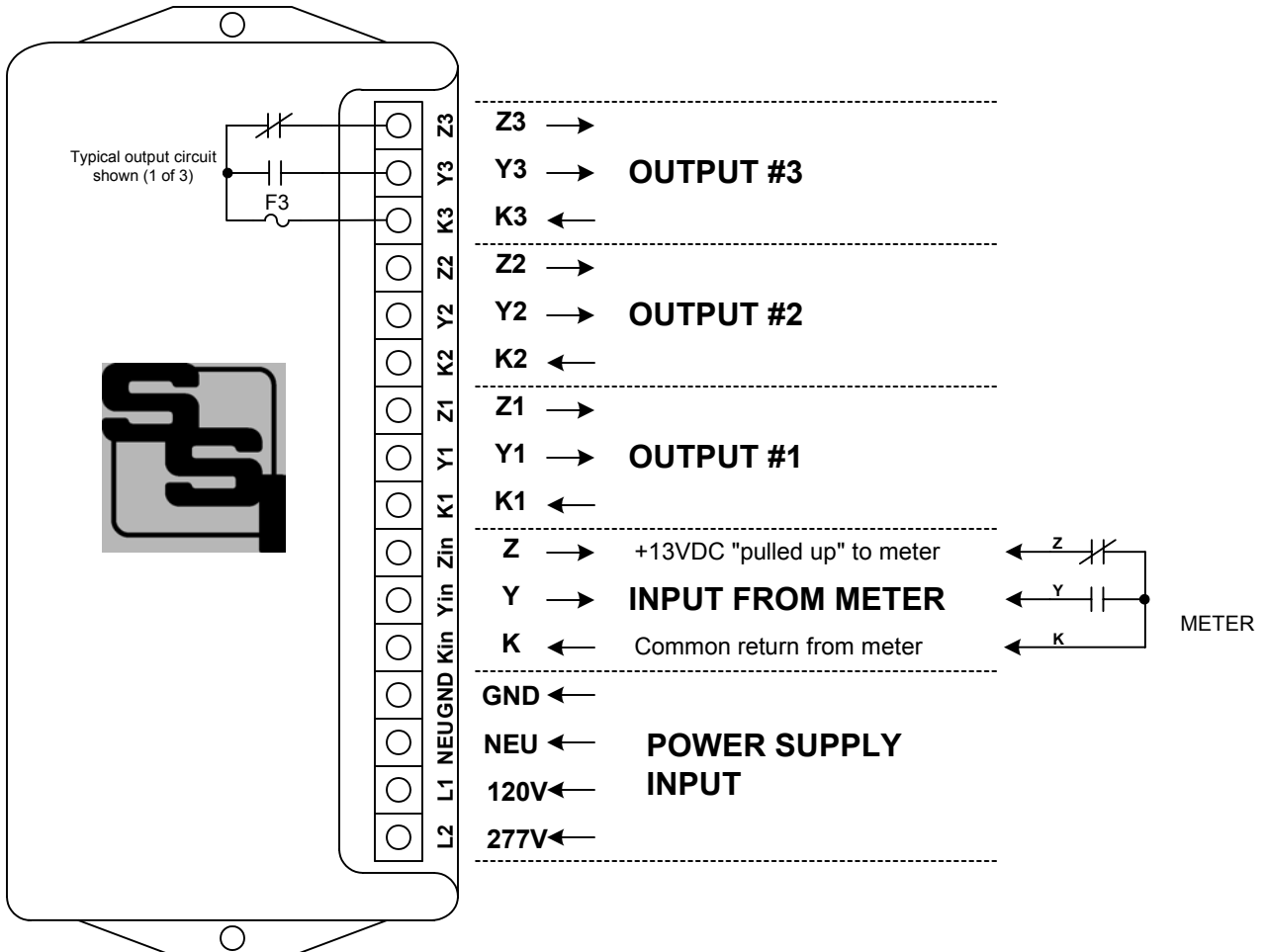

MOUNTING POSITION - The RPR-3PS can be mounted in any position.

POWER INPUT - For a 120VAC power supply, connect the "hot" lead to the **L1** terminal. For a 208 to 277VAC power supply, connect the "hot lead to the **L2** terminal. Connect the Neutral power supply lead to the **NEU** terminal. Connect the electrical system ground to the **GND** terminal.

METER CONNECTIONS - The RPR-3PS's K, Y and Z input terminals should be connected to the meter's K, Y and Z terminals: K to K, Y to Y, and Z to Z. The RPR-3PS's Y and Z terminals provide a "pulled-up" +13VDC wetting voltage to the meter. The K terminal is the common return.

OUTPUTS - Three 3-wire isolated outputs are provided on the RPR-3PS. Arc suppression for the contacts of each solid-state relay are provided internally. The output loads should be limited to 1/2 Amp by fuses F1, F2 and F3. One-half Amp fuses are supplied standard with the unit unless otherwise specified.



SOLID STATE INSTRUMENTS

a division of Brayden Automation Corp.
6230 Aviation Circle, Loveland Colorado 80538
Phone: (970)461-9600 Fax: (970)461-9605
E-mail: support@solidstateinstruments.com

RPR-3PS Wiring Diagram

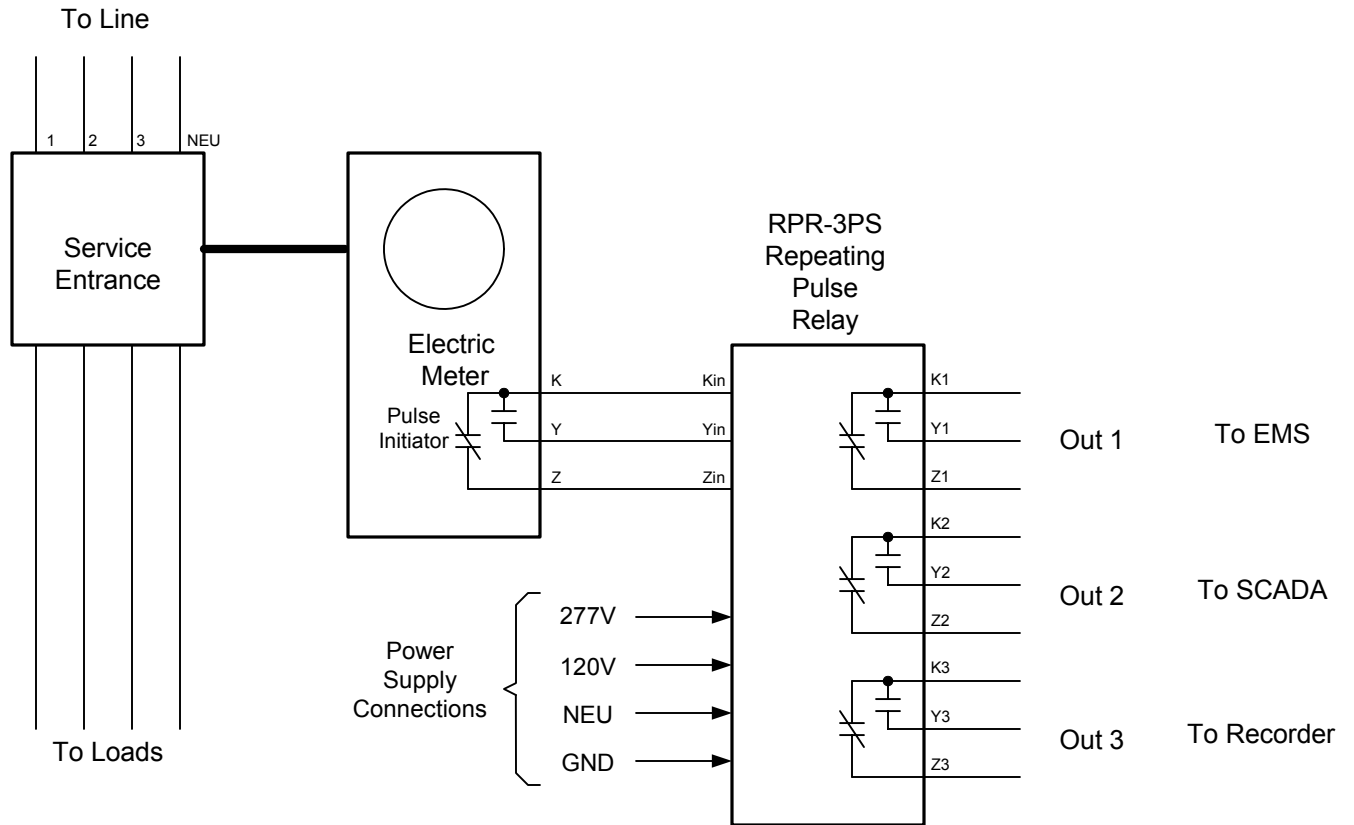

RPR-3PS Repeating Pulse Relay Wiring Diagram		REVISIONS	
		NO.	DATE
DATE ORIGINAL	SCALE		
11/24/08	N/A		
LATEST REVISION	JOB NO.	CHECKED	DRAWN
			WHB

**Brayden Automation Corp./
Solid State Instruments div.**
6230 Aviation Circle
Loveland, CO 80538
(970)461-9600
(970)461-9205 fax
www.solidstateinstruments.com