

INSTRUCTION SHEET

SPR-2LV-SP6 PULSE ISOLATION RELAY

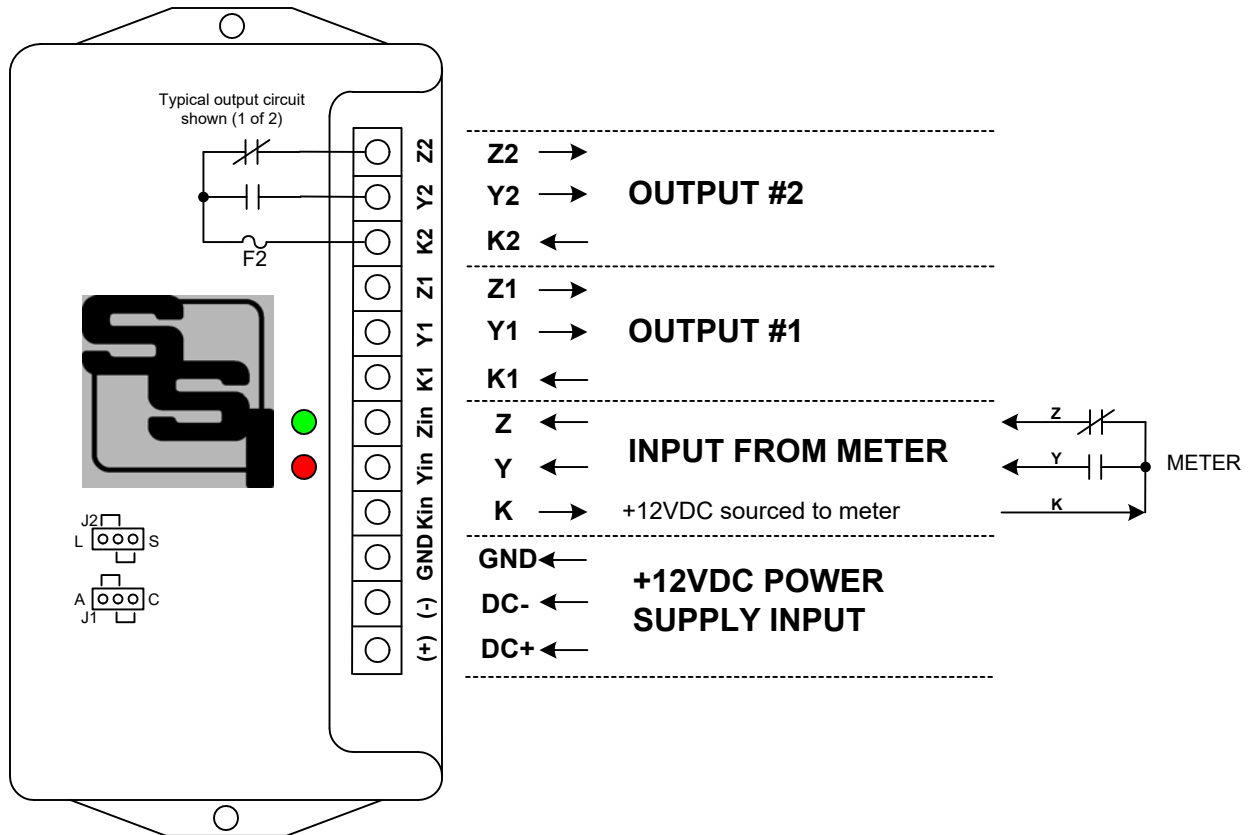

MOUNTING POSITION - The SPR-2LV-SP6 may be mounted in any position.

POWER INPUT - Connect the positive lead (+) of the 12VDC supply to the (+) terminal. Connect the negative (-) lead to the (-) terminal. Connect the **G** terminal to electrical system ground. If the 12V power supply's ground and electrical system ground are the same thing, connect the terminals together and to the common ground.

METER CONNECTIONS - The SPR-2LV-SP6 can be used with either a 2-Wire(Form A) or 3-Wire(Form C) input. In the 3W (Form C) input mode, the SPR-2LV-SP6's "K", "Y" and "Z" input terminals should be connected to the meter's "K", "Y" and "Z" terminals. In the 2W (Form A) mode, connect the "K" and "Y" terminals to the meter's "K" and "Y" terminals. The SPR-2LV-SP6's "Y" and "Z" terminals provide the +12VDC "pulled up" wetting voltage to the meter's Y and Z terminals. The "K" terminal is the common return. Put Jumper J1 in the correct position for the desired input as shown above: Left=2-Wire(A), Right=3-Wire(C).

OUTPUTS - Two 3-wire (Form C) isolated outputs are provided. Transient voltage protection for the contacts of each relay is provided by MOV's on board. The output loads should be limited to 100 mA at 250 VAC/VDC, 800mW max, and are protected by fuses F1& F2. One-tenth (1/10) Amp fuses are supplied standard. Jumper J2 sets the long(L) or short(S) output modes. The long mode sets the outputs to the same pulse width as the input. The short mode sets the outputs for a fixed 100mS wide pulse width. Put Jumper J2 in the correct position for the desired output mode as shown above: Left=Long, Right=Short. More information on long and short pulses on page 2.



SOLID STATE INSTRUMENTS

a division of Brayden Automation Corp.

6230 Aviation Circle, Loveland, Colorado 80538

Phone: (970)461-9600

E-mail: support@brayden.com

WORKING WITH THE SPR-2-SP6 RELAY

OPERATING MODES: The SPR-2-SP6 Repeating Pulse Relay allows the outputs to be configured for either the "Long" or "Short" pulse output mode. In the Long mode, the outputs simply follow the input. Output pulse widths are equal to input pulse widths. With the "long" output configuration selected, pulse speeds of up to 72,000 pulses per hour (20/sec) are possible. Figure 1 below shows the timing diagram for the "long" output mode.

Figure 1: 2-Wire or 3-Wire LONG Output Operation

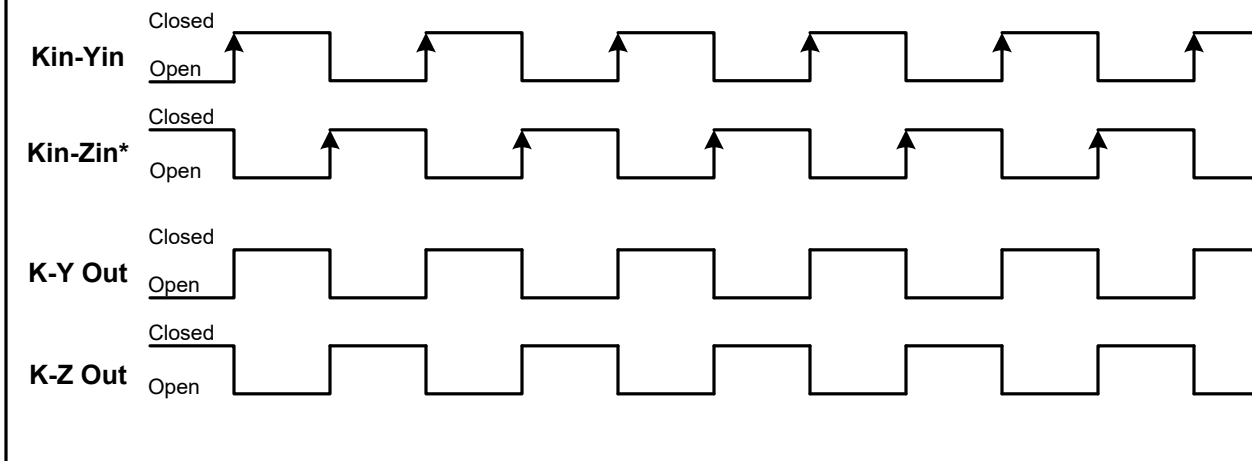

In the Short output mode, shown in Figure 2 below, an output pulse (K-Y closure) with a fixed width (T1) of 100mS occurs each time the input is triggered. Correspondingly, the K-Z output opens for 100mS (T2) each time the input is triggered. In the "short" mode, the output pulse rate is limited to 9 pulses per second, or about 32,400 pulses per hour.

Figure 2: 2-Wire or 3-Wire SHORT Output Operation

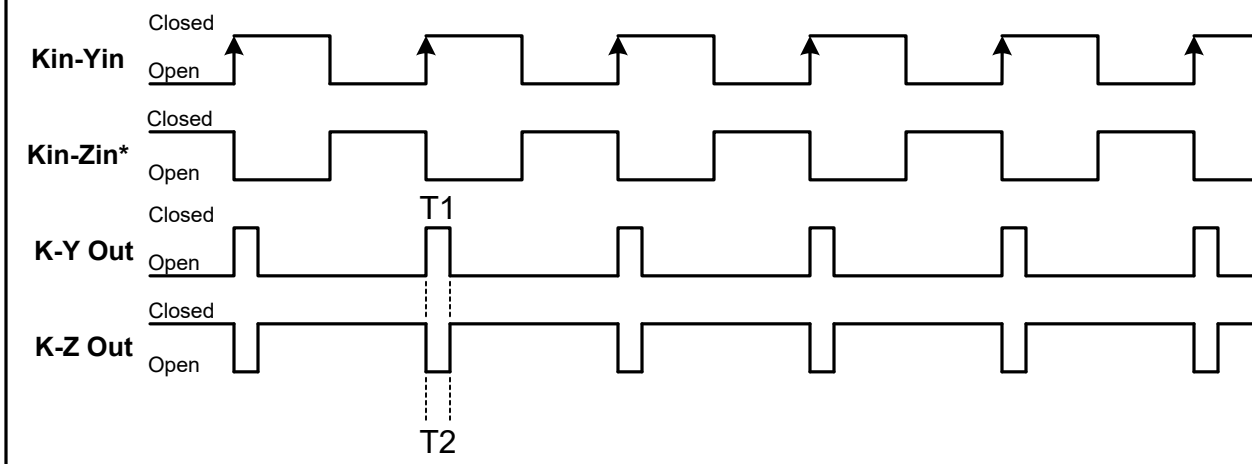

If the input pulse rate is greater than 9 pulses per second, it is recommended that the LONG pulse output mode be used. Contact the factory for technical support at (970)461-9600.

SPR-2LV-SP6 Wiring Diagram

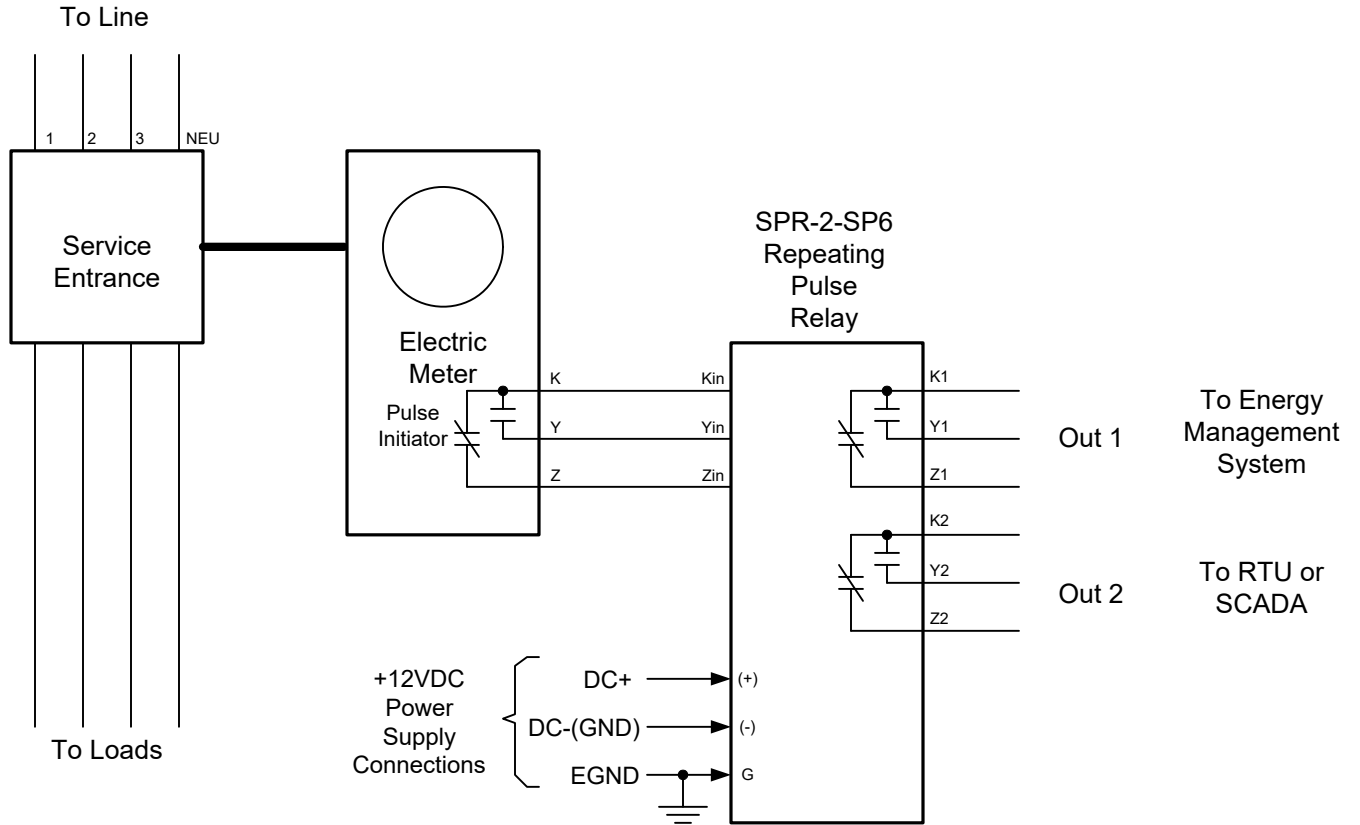

SPR-2LV-SP6 WiringDiagram.vsd

<p>SPR-2LV-SP6 Pulse Isolation Relay Wiring Diagram</p>		<p>REVISIONS</p>	
		NO.	DATE
DATE ORIGINAL	SCALE		
08/18/23	N/A		
LATEST REVISION	JOB NO.	CHECKED	DRAWN
			WHB

**Brayden Automation Corp./
Solid State Instruments div.**
6230 Aviation Circle
Loveland, CO 80538
(970)461-9600
support@brayden.com
www.solidstateinstruments.com