

INSTRUCTION SHEET

OPR-4 OPTICAL FIBER PULSE RECEIVER

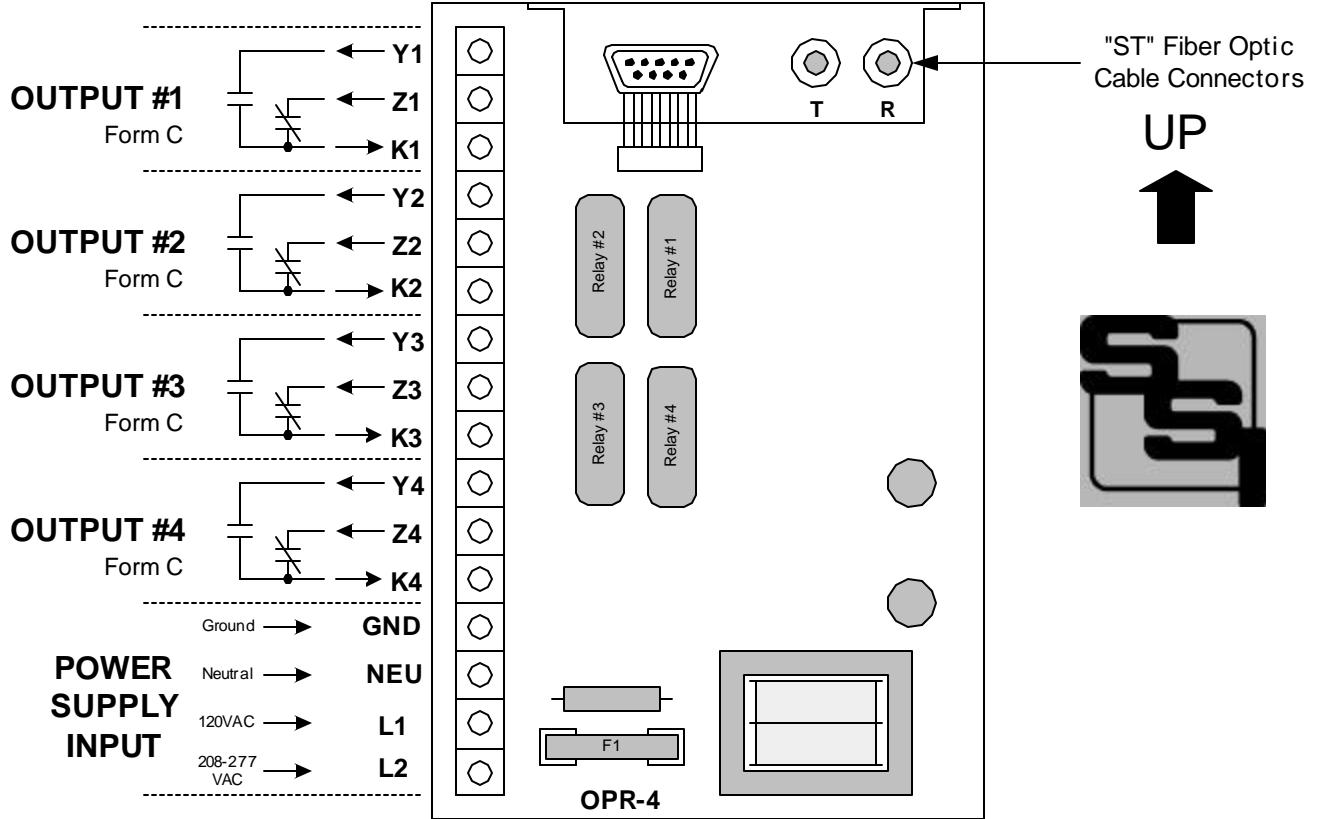

MOUNTING POSITION - The OPR-4 MUST be mounted in a vertical position, as shown above.

POWER INPUT - The OPR-4 can be powered by 120VAC or 208 to 277VAC. Connect the GND terminal to the electrical system ground. Connect the Neutral lead to the NEU terminal. Connect the L1 terminal to the 120VAC "Hot" lead for 120VAC operation. Connect the L2 terminal to the 208, 240, or 277 "Hot" lead. **Do not use both L1 and L2. Exercise caution when board is energized. There is voltage present at L1 and L2 when powered.**

RELAY OUTPUTS - The OPR-4 has four KYZ pulse outputs, that can be used as either 2-Wire (Form A) or 3-Wire (Form C). They are K1,Y1, & Z1 for output #1; K2,Y2, & Z2 for output #2; K3,Y3, & Z3 for output #3; and K4,Y4, & Z4 for output #4. For 2-Wire mode, the K & Y or the K & Z terminals may be used. For 3-Wire mode, all three wires must be used. Relay outputs are electrical isolated, dry-contact type with NO sourced voltage. The user must supply their own wetting voltage.

FUSE - The power supply fuse (F1) supplied on the OPR-4 is 1/2 Amp, type 3AG. Because the power supply voltage terminals are configured as 120V (L1) and 208-277V (L2) the fuse is located in the neutral power supply lead. Voltage may be present on the L1 and L2 terminals and circuitry on the board when the fuse is blown. Care should be exercised to disconnect all power to the board at the circuit breaker before servicing the system.

GROUND - The GND terminal on the OPR-4 is a common ground with the chassis and is connected to the Chassis by means of the middle right-hand mounting screw. Therefore, if necessary, the electrical system ground can be connected to the OPR's chassis. Do not tie the Ground and Neutral terminals together.



SOLID STATE INSTRUMENTS

a division of Brayden Automation Corp.

6230 Aviation Circle, Loveland Colorado 80538

Phone: (970)461-9600 Fax: (970)461-9605

E-mail: support@solidstateinstruments.com

INSTRUCTION SHEET

OPR-4 OPTICAL FIBER PULSE RECEIVER (con't)

Fiber Optic Cable Connections - Locate the two "ST" fiber optic ports on the OPR-4's media convertor module. Connect the fiber optic cable to these ports using the twist lock connections. The cables should be "crossed" such that each cable is connected to the "T" fiber optic port on one end and the "R" fiber optic port on the other end.

The OPR-4 will receive pulse information from the OPT-4 Optical Fiber Pulse Transmitter up to approximately 5000 meters or about 3 miles using multimode fiber. Care should be taken to follow all proper fiber optical cable implementation standards. See the System Block Diagram below.

OPL SYSTEM BLOCK DIAGRAM

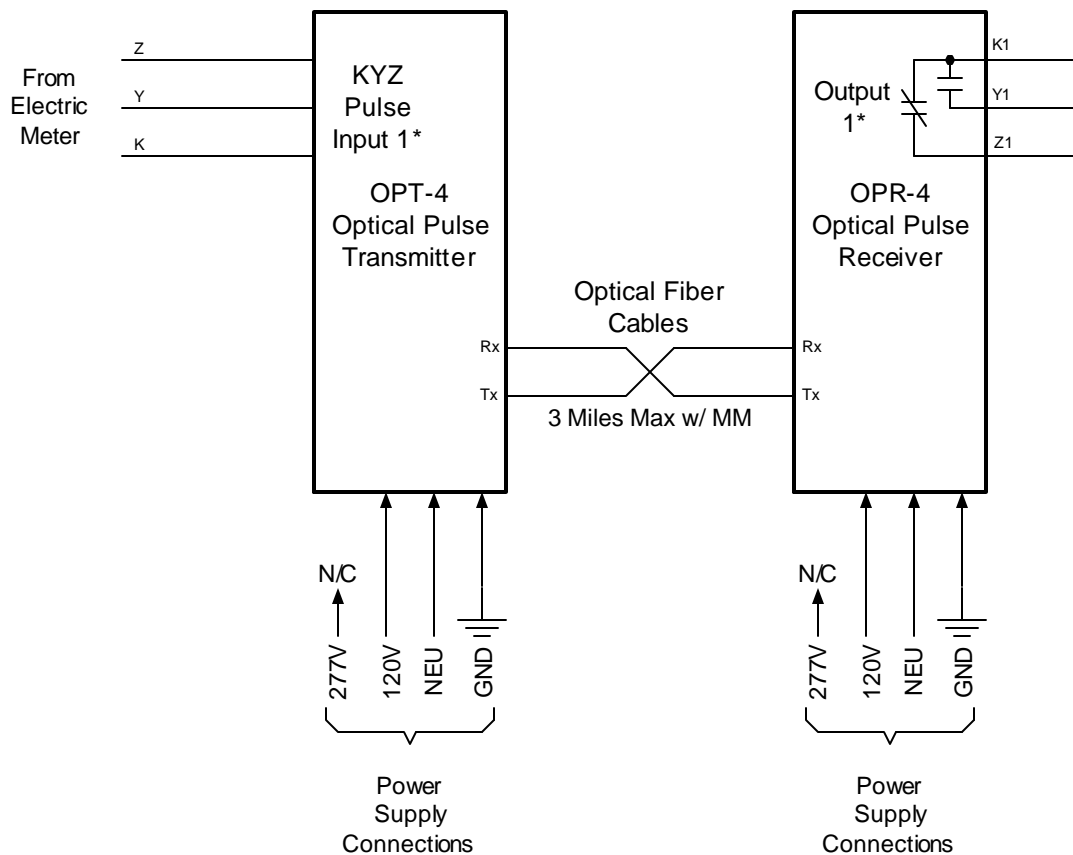

* Only 1 input/Output Circuit Shown



SOLID STATE INSTRUMENTS

a division of Brayden Automation Corp.

6230 Aviation Circle, Loveland Colorado 80538

Phone: (970)461-9600 Fax: (970)461-9605

E-mail: support@solidstateinstruments.com